

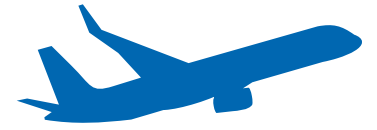

# Wayfinding Guideline & Sign Standards

**2015**





# Table of Contents

- Section 1 Purpose & Scope
- Section 2 Wayfinding Methodology
- Section 3 Design Principles & Graphic Standards
- Section 4 Libraries
- Section 5 Typical Sign Faces
- Section 6 Sign Box Detail Standards
- Section 7 Additional Guidelines for Tenants
- Appendix





# Section 1

## Purpose & Scope

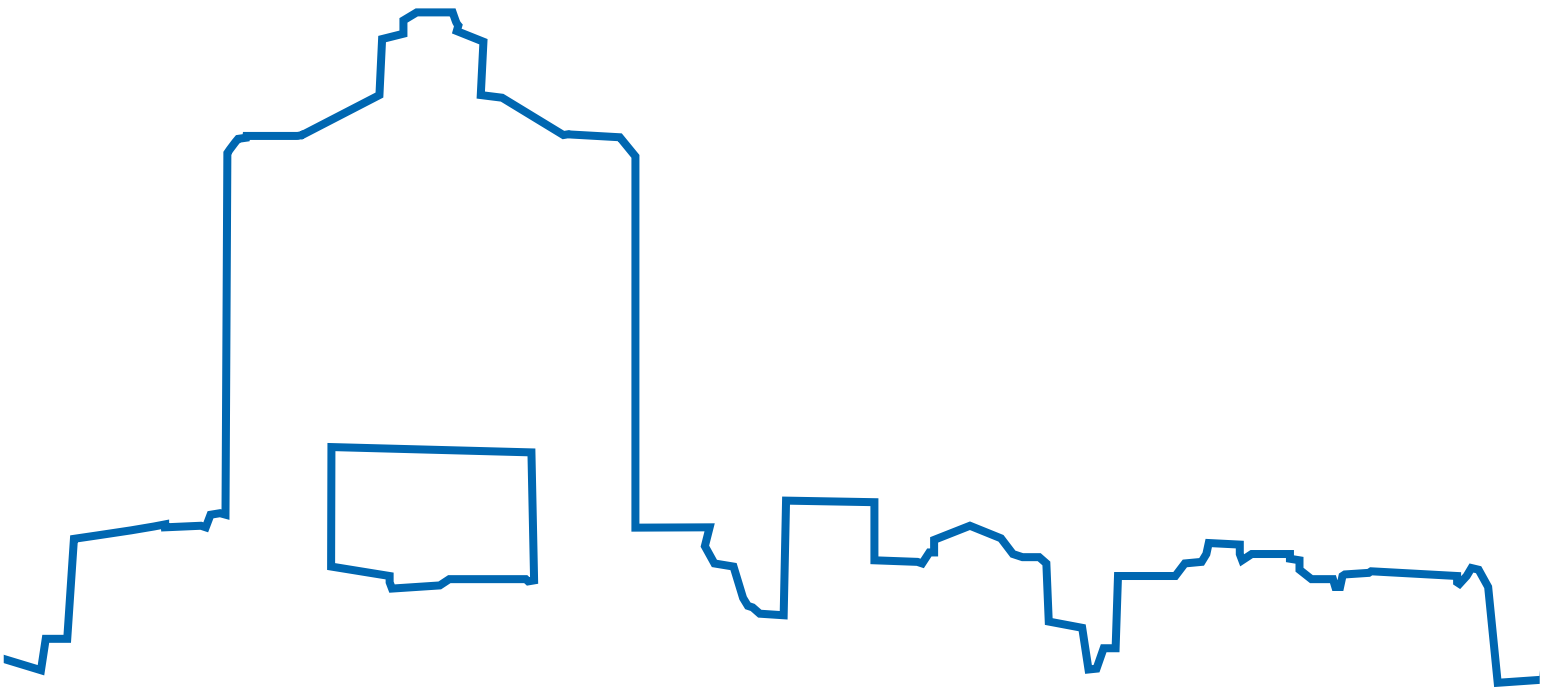

## 1.1 INTRODUCTION

The goal of this document is to standardize the process for designing and implementing the wayfinding signage systems at the airports operated by the Massachusetts Port Authority (Massport).

Signs are integral to successful wayfinding in airports. They orient and guide users through the airport environment. With the multitude of destinations and amenities at an airport, the number of wayfinding signs a user must read and process can be overwhelming and can cause confusion. A unified and consistent family of signs creates a positive airport experience.

## 1.2 PURPOSE

The *Wayfinding Guideline & Sign Standards* is the primary reference for Massport's tenants and consultants designing and implementing airport wayfinding signage. This document defines the process for wayfinding analysis; outlines the required submittals and deliverables for signage projects; and provides the standards and design criteria to be used when designing the signage system.

## 1.3 SCOPE

Signs regulated by this document include all interior and exterior airport wayfinding signs – both new and existing – within the airport properties which provide direction, identification, or information to the public at:

- Terminals
- Curbsides (arrivals and departures)
- Parking areas
- Rental Car Center
- Service buildings accessible to the public
- Airport roadways

Temporary signs that provide direction, identification, or information to the public are also regulated by this document with some exceptions. Temporary signs are used on an interim basis during construction or to address temporary operational changes. In some cases, it may be more practical to fabricate these signs using a different quality

of materials. Any deviation from the *Wayfinding Guideline & Sign Standards* must be reviewed and approved by Massport.

Signs NOT regulated by this document include:

- Vehicular pavement markings
- Signs regulated under the Manual on Uniform Traffic Control Devices (MUTCD)
- Areas in rental car facilities controlled by rental car agencies
- Non-public areas of Massport facilities

Guidelines and standards established by this document include:

- Wayfinding Analysis Process
- Design Process and Review
- Deliverables
- Design Principles
- Sign Graphic Standards
- Sign Box Fabrication Standards
- Specifications

#### **1.4 MASSPORT AIRPORTS**

The airports in adherence to this document include:

- Boston Logan International Airport
- L.G. Hanscom Field
- Worcester Regional Airport

##### **Boston Logan International Airport**

Boston Logan International Airport (BOS) is New England's largest transportation center and generates approximately \$7 billion in economic activity each year. Located in East Boston, it has a 1,700 acre footprint that includes landside and airside functions, a fire department, police department, central plant, MBTA Blue Line Station, Logan Boat Dock, Hilton and Hyatt Hotels, a non-denominational chapel, and 27 acres of landscaping along the roadways and terminals.

Boston Logan International Airport (BOS) has four passenger terminals – A, B, C, and E – each with its own ticketing, baggage claim, and ground transportation facilities. Terminal D is not longer active. In all, there are 94 gates with contact jet bridges and nine regional jet gates at the airport. A system of pedestrian bridges with moving walkways connects each of the terminals to the airport’s major parking garage, Central Parking.



*Figure 1-a: Boston Logan International Airport Area Plan*

### Terminal Buildings

**Terminal A** opened in 2005 and consists of a main terminal building and a remote satellite building that is connected by an underground pedestrian tunnel. Gates A1-A12 are located in the main terminal building and Gates A13-A22 are located in the satellite building.

**Terminal B** was opened in 1979 and consists of two terminal buildings separated by a 5-level parking garage. The South Terminal Building (Pier B), referred to as the US Airways side, includes Gates B1-B21. The North Terminal Building, referred to as the American side (Pier A), includes Gates B22-B38. Pre-security connections to the two terminal buildings are made via crosswalks through the Terminal B Garage at both the arrivals and departures street levels. In 2014, the two piers were connected post security.

**Terminal C** was opened in 1963 and houses three groups of gates that are located in separate piers or wings of the building. Gates C11-C21 are located in Pier B (northeast wing), Gates C25-C36 are located in Pier C (southeast wing), and Gates C40-C42 are located in Pier D (southwest wing). A new security checkpoint was completed in 2011 that connects the two post-security north piers. Pier D features its own dedicated security checkpoint. The C to E connector, scheduled to open in 2016 will provide Gates C8 thru C10 and post security access to Terminal E hold rooms.

**Terminal E** was constructed in 1974 and serves as the Airport's international terminal with U.S. Customs and Border Patrol processing. Major renovations were completed in 2006 which included an addition to the original building and new face for the terminal with many of the pre-security landside functions including ticketing and a Meet and Greet Hall located here. The original building still remains and houses the post-security landside functions and Gates E1-E8.

### **Rental Car Center (RCC)**

Boston Logan Airport's 120,000 square foot Rental Car Center (RCC), was opened in 2013 on a 49 acre site. It serves multiple major car rental companies with a four level 1.3 million square foot parking structure for 3,200 cars, rental car offices and a customer service hall. Over 30 buses an hour serve the facility bringing passengers from all the terminals and the T's Blueline Airport Station. A state of the art Ground Transportation Operations Center (GTOC,) is located on the lower level. Also on the lower level is the Noodle Island Community Room which is available for use by approved community and civic groups.

### **Parking Areas**

BOS has a number of parking facilities for short-term, long-term, and economy parking including three surface parking lots and three parking garages.

**Central Parking** is the airport's main parking garage located central to all terminals and offers short-term and long-term parking. The garage complex consists of three parking structures that are connected by vehicular bridges at most levels. Enclosed elevated pedestrian bridges connect to each terminal and are located on the fourth level allowing passengers to travel directly to their destination terminal without going outdoors.

**B Parking** is a 5-level garage located between the two buildings that comprise Terminal B that offers both short-term and long-term parking. Connection to Terminal B from the garage is made via crosswalks to the departures level as well as upper level elevator/stair connectors.

**Economy Parking** is a 3-level satellite parking garage that offers cost-saving, long-term parking. It is located at the intersection of Service Road and Prescott Street. Connection to the terminals can be made using Massport's complimentary on-airport shuttle bus system.

**E Lot 1** and **E Lot 2** are two surface parking lots at the arrivals level of Terminal E. E Lot 1 - Parking is used for short-term and long-term parking and E Lot 2 - Parking is used for overflow parking at the airport. Connection to Terminal E is made via crosswalks at the roadway level.

**The Cell Phone Lot** is a surface parking lot for motorists picking up arriving passengers where they can wait until their party has arrived and they can be picked up at the curbside. The parking lot is located at the intersection of Hotel Drive and Service Road and is a complimentary service provided by the airport.

### **Airport Roadways**

The roadway system at Logan Airport includes all roadways within the airport property. The circulation system includes an upper elevated roadway at terminal fronts to separate vehicular arrivals circulation from departures circulation simplifying the airport driving experience.





### **L.G. Hanscom Field**

L.G. Hanscom Field (BED) is a full-service general aviation airport serving a mix of corporate aviation, private pilots, flight schools, and commuter/commercial air services, including a fixed-base operator, charters, and light cargo. It is located about 20 miles northwest of Boston in Bedford, Massachusetts off Route 128/95. With access to Eastern Massachusetts, it is a popular choice for business executives as an alternative to BOS.



*Figure 1-b: L.G. Hanscom Field Area Plan*

### **Worcester Regional Airport**

Worcester Regional Airport (ORH) is a commercial and general aviation airport located in Central Massachusetts. Facilities include a passenger terminal with four jetway gates, two ramp-level gates, and two baggage carousels. The airport provides general aviation services, including a fixed-base operator.

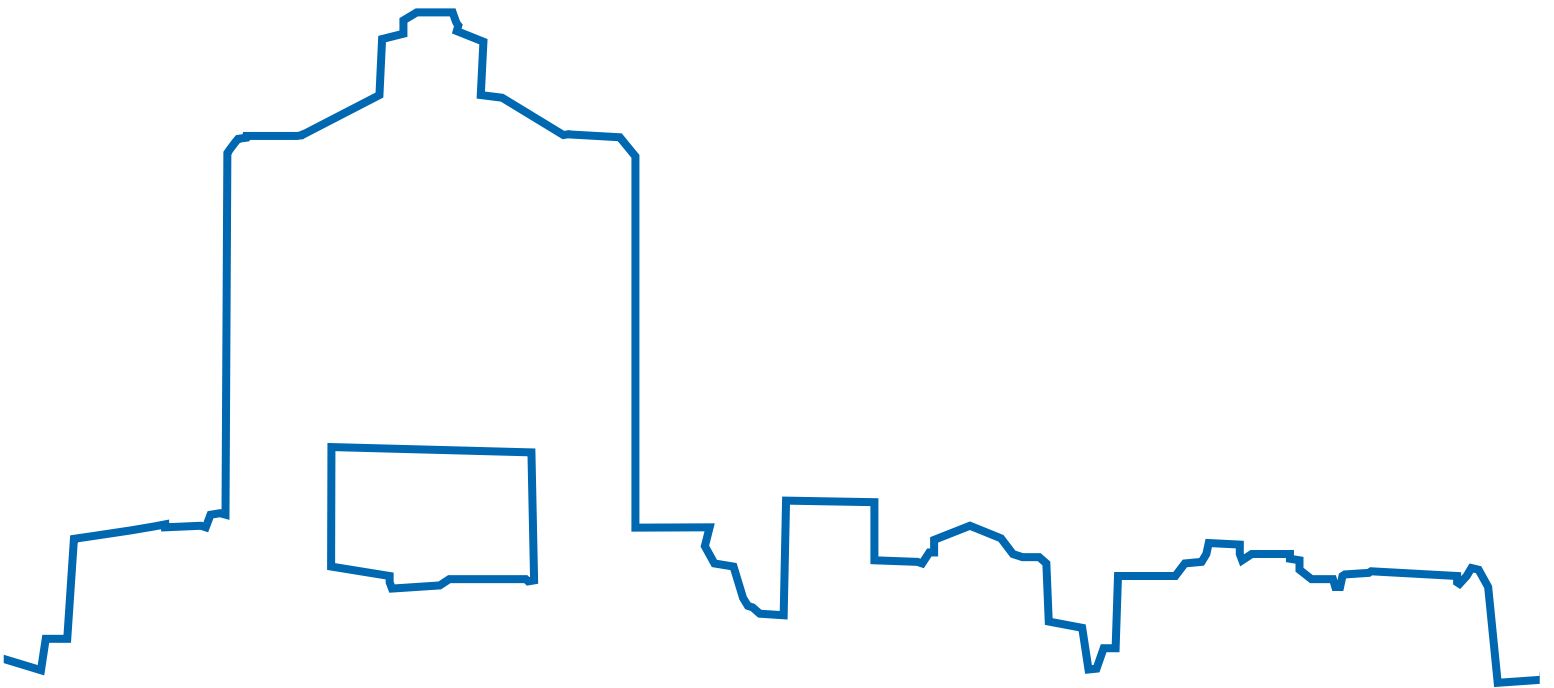

*Figure 1-c: Worcester Regional Airport Area Plan*



## Section 2

### Wayfinding Methodology



## 2.1 INTRODUCTION

A successful wayfinding signage system provides airport users with a comprehensive path of travel that places information along the users' path allowing them to make the necessary decisions and take the proper actions to arrive at their intended destination. It is a complex system of messages that not only directs, but informs, identifies, and reinforces. The design of the wayfinding signage system is an integral component of the architecture and engineering (AE) design process of a project. Wayfinding should inform architecture, especially in complex facilities such as airports. Wayfinding is more than signage, and should not be an additive solution addressed at the end of a project.

Wayfinding is spatial problem solving and understanding the built environment is essential to designing a successful signage system. Signs should be integrated into a space to enhance the wayfinding experience for the user. They should be carefully located not to obstruct sight lines or architectural wayfinding cues found in the built environment, yet be prominent enough to provide users with just the right amount of information when needed. A successful wayfinding system allows the first-time user to intuitively self navigate the airport.

## 2.2 WAYFINDING ANALYSIS

With all the complexities of an airport environment, a wayfinding analysis is necessary to achieve a successful wayfinding signage system. The following methodology shall be used when designing and implementing any signage project at airports operated by Massport:

1. Identify points of entry or origin and primary destinations
2. Determine user circulation pathways to these destinations
3. Determine major decision points along these pathways
4. Locate directional signs at major decision points
5. Create 3D study models of major decision points
6. Formulate preliminary messages for these directional signs
7. Locate signs that identify all major destinations (identification signs)
8. Formulate preliminary messages for these identification signs
9. Identify areas that require additional navigational aids (reinforcement directional signs and informational signs)
10. Formulate preliminary messages for these reinforcement directional and informational signs

### **Identify Entries, Origins, and Destinations**

Understanding where people are coming from and going to is critical to identifying wayfinding priorities. Passengers arrive from multiple locations and various directions. Filtering this information with a thorough analysis allows messages to be prioritized to specific pathways. Attention should be paid not only to the entries, origins, and destinations for arriving and departing passengers, but to transferring passengers that may need to move between and within terminals.

There are two types of destination points: primary and secondary. Primary destination points generally include major airport functions, such as terminals and ground transportation. Secondary destination points generally include auxiliary services and support functions, such as restrooms and concessions. Categorizing destinations into primary and secondary locations helps with determine user circulation pathways, described below.

### **User Circulation Paths**

User circulation paths are possible routes a user may take to reach his or her destination. Routes begin at points of entry and origins and end at destinations. Primary circulation paths are routes to primary destinations, i.e. terminal, gate, or ground transportation, and secondary circulation paths are routes to secondary destinations, such as restrooms and concessions. For the departing passenger, a primary circulation path includes: arriving at the terminal curbside; checking in with the airline at the ticket counter; dropping baggage off; moving through the security checkpoint; and proceeding to the departure gate. Conversely for the arriving passenger, the primary circulation path may begin with arriving at the gate, picking up luggage at Baggage Claim, and locating ground transportation. Both of these pathways may also begin and end in an airport parking garage.

Pathways should always be traced back to include areas that may be outside of the area of work, but inside the possible message area. To ensure a successful signage system, all possible user paths must be charted, including primary and secondary user circulation paths for both arriving and departing passengers.

The following characteristics should also be considered when defining wayfinding paths:

- Vertical circulation elements, such as escalators and elevators, may be along a circulation path
- A primary circulation path may split off into a secondary circulation path
- There may be multiple destination points along the same path
- Two circulation paths may start at the same origin and split along the path to chart different routes to the same destination
- User paths may begin on one level and end on another level
- The same location may be a destination point for an arriving passenger and a point of entry or origin for a departing passenger

### **Decision Points**

Decision points are locations along a user path where the navigator is confronted with a wayfinding choice. This typically occurs where two or more user paths intersect or change direction.

It is useful to categorize decision points as major or minor, as this will help determine which areas need to be analyzed three dimensionally. Major decision points are typically where multiple user paths cross or intersect and are critical for achieving the overall goal of the wayfinding task.

### **Location of Signs**

Circulation patterns and natural lines of vision are the basis for determining the location of all signs.

Decision points will assist in determining where signs that provide direction should be located. As a rule of thumb, there should be a directional sign at every decision point where the sign is perpendicular to the path of travel. Signs should be located to precede decision points to allow sufficient time for passengers to react to each sign message.

The identification of destination points helps in determine where signs that provide identification should be located. As a rule of thumb, an identification sign should be provided at every destination point to confirm the arrival at a location.

The locations of critical wayfinding signs should be identified as early in the process as possible. This allows prime real estate areas, which are often attractive to retail branding and advertising, to be allocated to wayfinding.

### **3D Study Models**

Massport has found that the inclusion of 3D computer models greatly increases the ability for stakeholders to visualize and understand the wayfinding design process. Major and critical decision points should be modeled to evaluate whether there are obstructions that need to be considered when determining sign placement proposed.

### **Formulate Messages**

Messages along primary pathways should be developed as soon as possible in the process. Consistent use of terminology and message order are important considerations.

Messages should begin with general information and get more specific as a user moves closer to a destination. Messages should be relevant to the choices offered, as well as the larger goal of the navigational task or final destination.

### **Additional Aids and Signs**

Quite often signs need to be augmented with additional information. This includes supplemental directional signs or informational signs.

Supplemental directional signs are typically placed where there is a long distance between two decision points to reinforce a direction. Informational signs, such as directories may be placed to orient a user. The placement should be obvious to the navigator, but should not conflict with circulation pathways. These elements should be placed along passenger pathways as near decision points as possible.

### 2.3 SIGNAGE PROJECTS

Signage projects are categorized by Massport as either a Capital Project or a Tenant Alteration Application (TAA), and are reviewed by Aviation Business, Aviation Signage, and/or Capital Programs. Other stakeholders may include the Ground Transportation Unit and the Fire Department.

In a **Capital Project**, the lead person is the Project Manager. The Project Manager coordinates with the Manager of Aviation Signage at the inception of each project (whether large or small) to determine if the project requires signage. In some cases, the Project Manager and Project Team will be required to develop a Signage Plan and conforming signage design. In other cases, Aviation Signage may provide the needed signage. The approach is case by case.

For a **Tenant Alteration Application** (TAA) Project, the TAA Project Manager is the lead. The TAA Project Manager coordinates with the Manager of Aviation Signage at the inception of each project (whether large or small) to determine if the project requires signage. In some cases, the Project will be required to develop a Signage Plan; in other cases, Aviation Signage may provide the needed signage. The approach is case by case.

### 2.4 DELIVERABLES

The wayfinding design process, which requires close coordination among all parties and project elements, is to be included as part of the procedures and phases of the AE process. The following are recommended wayfinding deliverables for each phase of the AE process:

#### Schematic Design (15%)

The schematic design process is the problem discovery and concept solution period. A solid understanding of potential problems helps build consensus among project stakeholders project goals. This allows the designer to propose focused solutions that achieve the project goals and avoid being encumbered with 'wishlist' solutions.

- **Pathway Diagrams**

Portions of the wayfinding analysis effort is documented for this deliverable. Using floor plans as a basis, primary user circulation pathways for both departures and arrivals routes are charted and major decision points are indicated. Primary



circulation paths should be depicted as solid lines: red for arriving passengers and green for departing passengers. Decision points should be depicted as yellow circles. See Figure 2-a for an example of a Pathway Diagram deliverable.

- **Concept Sign Location Plan**

A Concept Sign Location Plan shows the initial locations of primary wayfinding signs and their preliminary messages. Messages should be included on the plan and not in a separate document as it will help the reviewer fully understand the concept proposed. See Figure 2-b for an example of a Concept Sign Location Plan deliverable.

- **Wayfinding Scope**

The wayfinding signage system scope should be established early on in the design process. For example, one needs to determine how many signs will be required, whether they are illuminated or non-illuminated, and whether variable message signs are required. This information can be used to create an order of magnitude cost estimate for the project.

### **Preliminary Design (30%)**

The preliminary design allows for the development and application of the concept agreed to in schematic design. The use of 3D study models and concept renderings is the preferred method of presenting work in this phase.

- **Pathway Diagrams**

Pathway diagrams are further developed during the Preliminary Design phase to include both primary and secondary user circulation paths for departures and arrivals. Primary circulation paths should be depicted as solid lines – red for arriving passengers and green for departing passengers – and secondary circulation paths as dotted lines of the same color. Decision points should be depicted as yellow circles. Two different sizes may be used to differentiate major and minor decision points. See Figure 2-c for an example of a deliverable for this phase.

- **Preliminary Sign Location Plans**

Sign Location Plans are further developed in the phase. Primary and secondary wayfinding signs proposed for the project should be shown as well as any

reinforcement directional signs or informational signs. Messages should be developed to include arrows at this phase and continue to be shown on the plans. See Figure 2-d for an example of this deliverable.

- **3D Study Views**

3D Study Views is a deliverable that compiles images taken from the 3D study model of the proposed wayfinding concept. A number of views at a variety of angles should be taken. See Figures 2-e, 2-f, and 2-g for examples of this deliverable.

### Design Development (60%)

The preparation of contract documents begins in this phase, including typical details. The 60% design submittal should include:

- Sign Location Plans
- Part Plans, where appropriate (required)
- Sections and Elevations
- Typical Details
- Draft Message Schedule
- Typical Sign Face Layouts
- Outline Specifications
- 60% Cost Estimate

### Sign Tag Designations

All signs need to be identified by a seven-digit reference number that is used on Sign Location Plans. The following example shows how the reference numbers are coded:

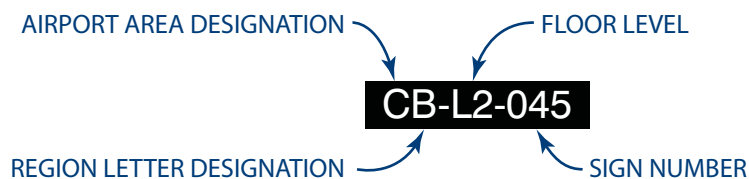

The example shown indicates that sign number 45 is located at the curbside of the departures level of Terminal B.

Airport Area Designations include:

- C - Curbside
- P - Parking
- R - Roadway
- T - Terminal

For programs at Massport Service Buildings, the Airport Area Designation and Region Letter Designation may be replaced with the Massport Building ID Number.

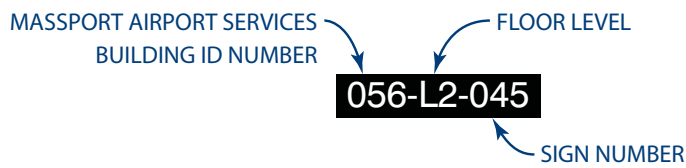

### Final Design (100%)

The contract documents and final specifications are completed.

- Contract documents
- Specifications
- Cost Estimate

## 2.5 GOVERNING CODES AND REGULATIONS

### Airport Reference

TRB's Airport Cooperative Research Program (ACRP) Report 52: Wayfinding and Signing Guidelines for Airport Terminals and Landside is designed to provide airports with the tools necessary to help passengers find their way in and around the airport.

The guidelines focus on four areas of the airport: (1) roadways — both on-airport, and off-airport access roads; (2) parking; (3) curbside and ground transportation; and (4) terminal.

In addition, the guidelines discuss developing a wayfinding strategy; the use of technology and visual displays; and color, fonts, and sizes.

### Roadway Reference

MassDOT manuals and publications should be consulted for design and construction details related to roadways. These references are available at the MassDOT website. <http://www.massdot.state.ma.us/>

### Governing Bodies and Authoritative Organizations

General regulatory sign requirements and governing codes, city ordinances and standards affecting Massport's signage system are listed below. It is the designer's responsibility to meet all current applicable codes and regulations of the following entities.

<b>AAAE</b>	American Association of Airport Executives
<b>AASHTO</b>	American Association of State Highway and Transportation Officials
<b>ACC</b>	Airport Consultants Council
<b>AIGA</b>	American Institute of Graphic Arts
<b>ANSI</b>	American National Standards Institute
<b>ASTM</b>	American Society for Testing and Materials
<b>ATA</b>	Air Transport Association of America
<b>AWI</b>	Architectural Woodwork Institute
<b>CAA</b>	Civil Aeronautics Administration
<b>CAB</b>	Civil Aeronautics Board

<b>CABO</b>	Council of American Building Officials
<b>CSI</b>	Constructions Specifications Institute
<b>FAA</b>	Federal Aviation Administration
<b>FHWA</b>	Federal Highway Administration
<b>IATA</b>	International Air Transport Association
<b>MassDOT</b>	Massachusetts Department of Transportation
<b>NEMA</b>	National Electric Manufacturers Association
<b>NFPA</b>	National Fire Protection Association

### Codes and Regulations

<b>ADAAG</b>	ADA Accessibility Guidelines
<b>ANSI</b>	American National Standards Institute
<b>IBC</b>	International Building Code
<b>LSC</b>	Life Safety Code (written by NFPA)
<b>MAAB</b>	Massachusetts Architectural Access Code
<b>MBC</b>	Massachusetts Building Code
<b>MUTCD</b>	Manual of Uniform Traffic Control Devices*
<b>NEC</b>	National Electrical Code
<b>SBCCI</b>	Standard Building Code
<b>UBC</b>	Uniform Building Code

\* Including The Massachusetts Amendments to the 2009 Manual on Uniform Traffic Control Devices and the Standard Municipal Traffic Code

2.5 SAMPLE DELIVERABLES

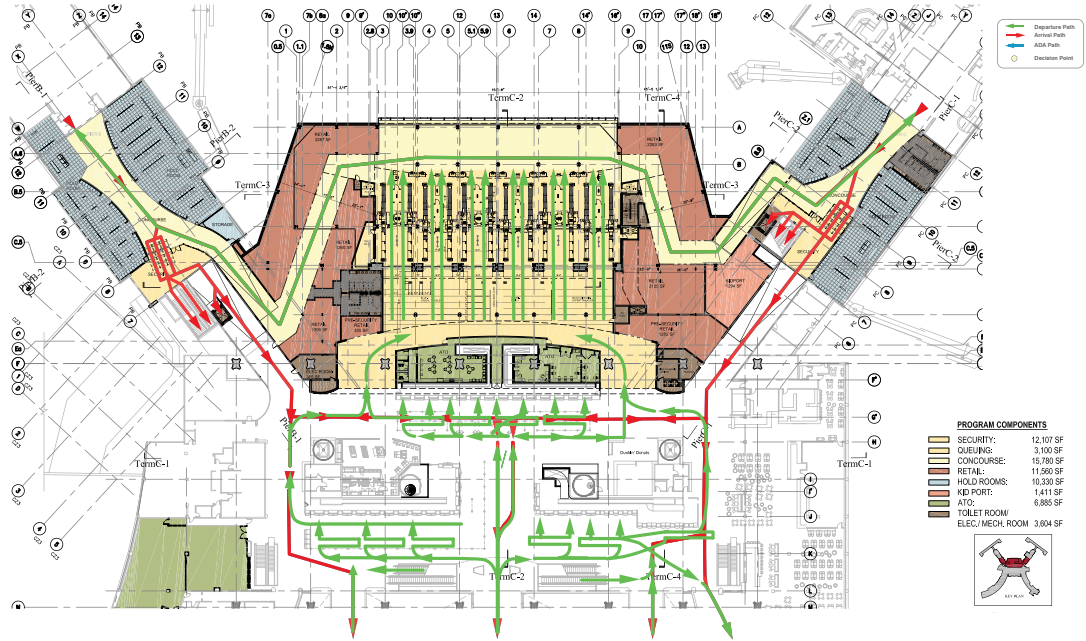

STV Incorporated Louis Nelson Design Inc Terminal C Checkpoint Security Checkpoint Passenger Pathways SK-01

Figure 2-a: 15% Schematic Design - Pathway Diagram

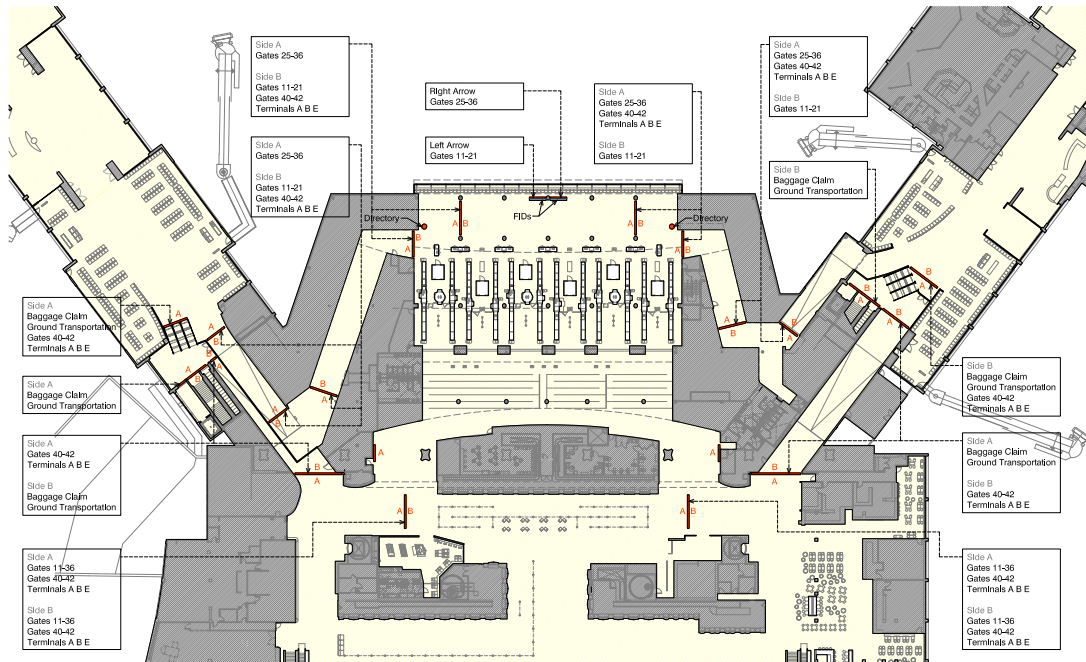

STV Incorporated Louis Nelson Design Inc Terminal C Checkpoint Security Checkpoint Sign Location Plan SK-04

Figure 2-b: 15% Schematic Design - Concept Sign Location Plan



SECTION 2 WAYFINDING METHODOLOGY

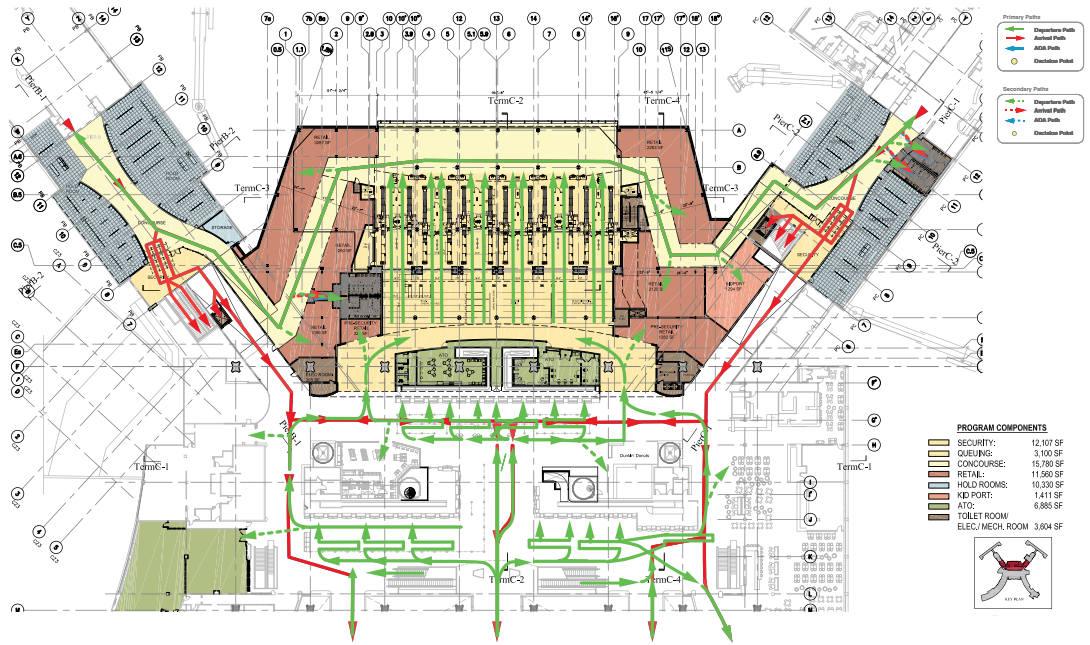

STV Incorporated Louis Nelson Design Inc Terminal C Checkpoint Conceptual Sign Locations date: feb. 24, 2010 scale: rtd scale: rtd scale: rtd  
 225 Park Avenue South PO Box 995 New York, NY 10003  
 Terminal C Security Checkpoint Passenger Pathways SK-01

Figure 2-c: 30% Preliminary Design - Pathway Diagram

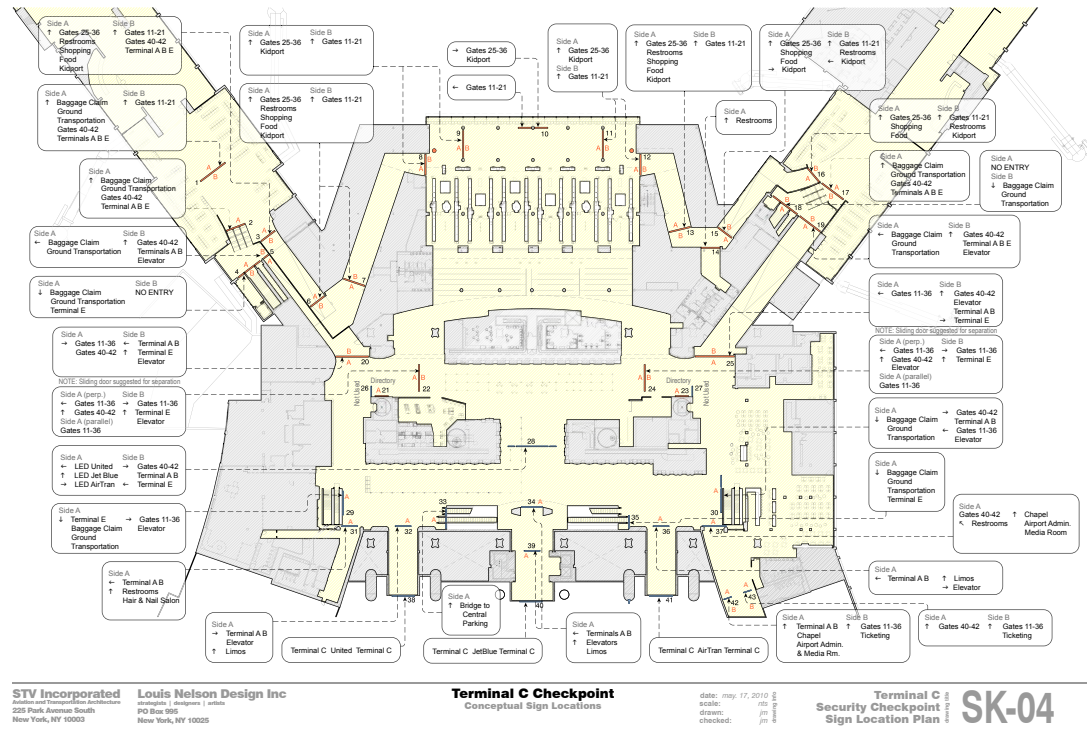

STV Incorporated Louis Nelson Design Inc Terminal C Checkpoint Conceptual Sign Locations date: may 17, 2010 scale: rtd scale: rtd scale: rtd  
 225 Park Avenue South PO Box 995 New York, NY 10003  
 Terminal C Security Checkpoint Sign Location Plan SK-04

Figure 2-d: 30% Preliminary Design - Preliminary Sign Location Plan



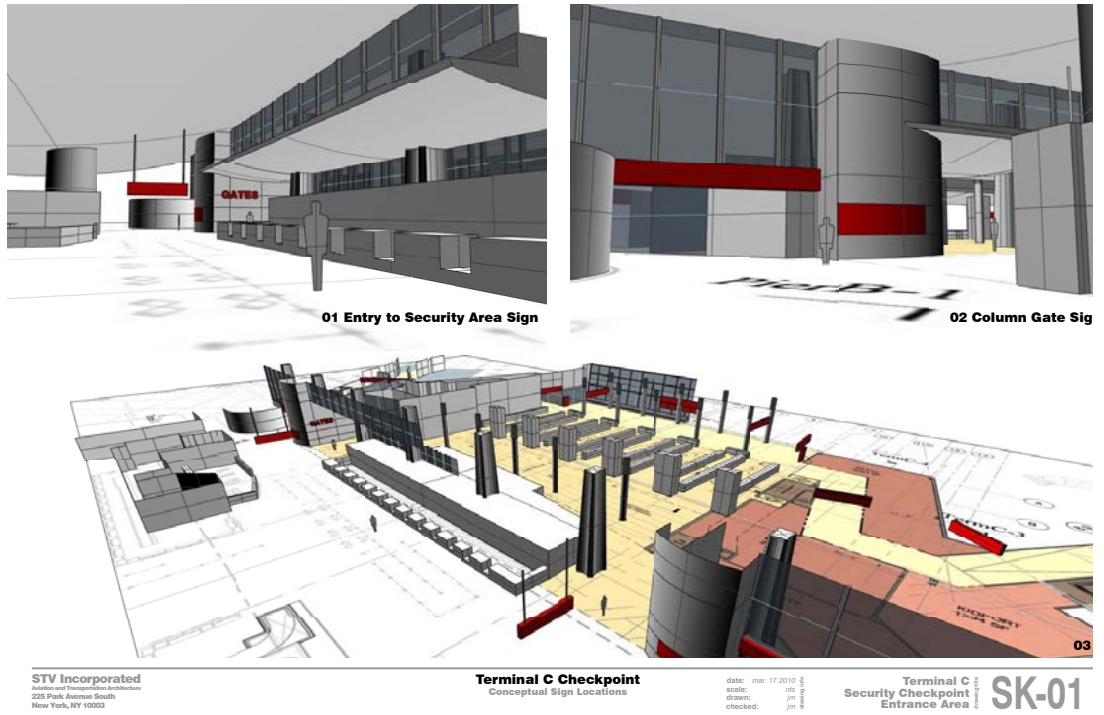

Figure 2-e: 30% Preliminary Design - 3D Study Views 01

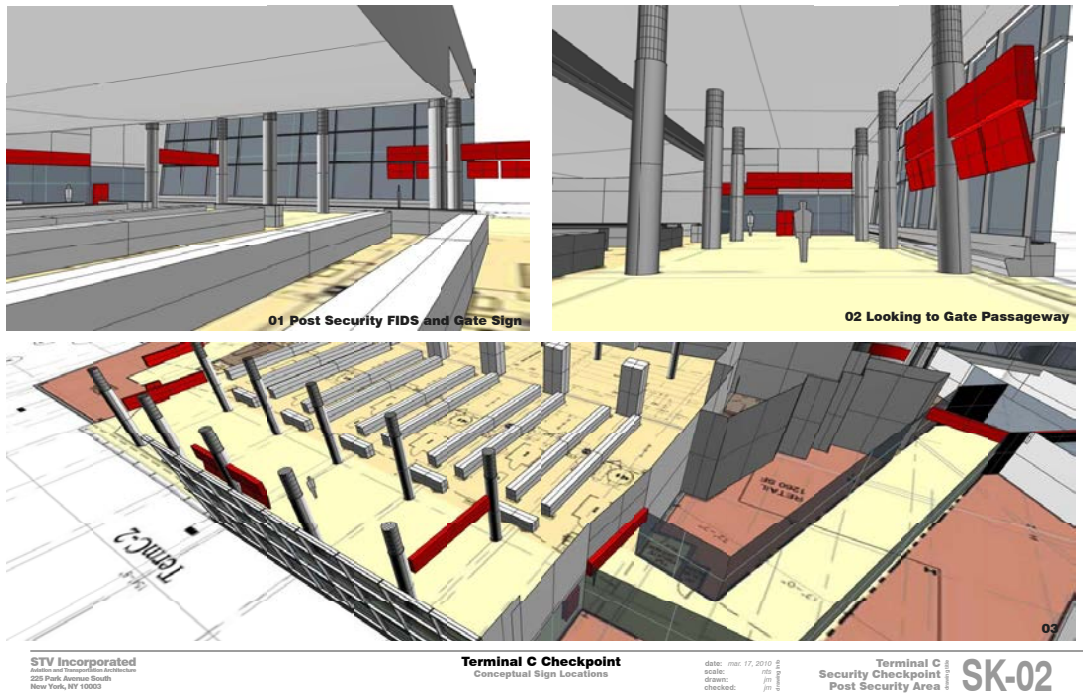

Figure 2-f: 30% Preliminary Design - 3D Study Views 02



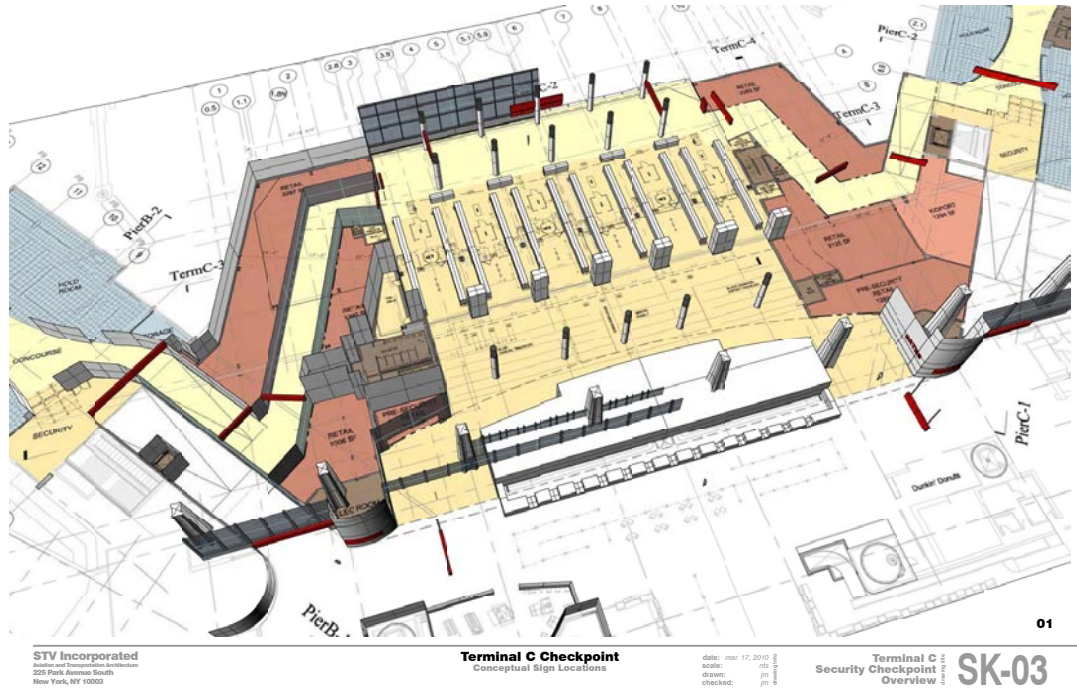

Figure 2-g: 30% Preliminary Design - 3D Study Views 03



SECTION 2 WAYFINDING METHODOLOGY

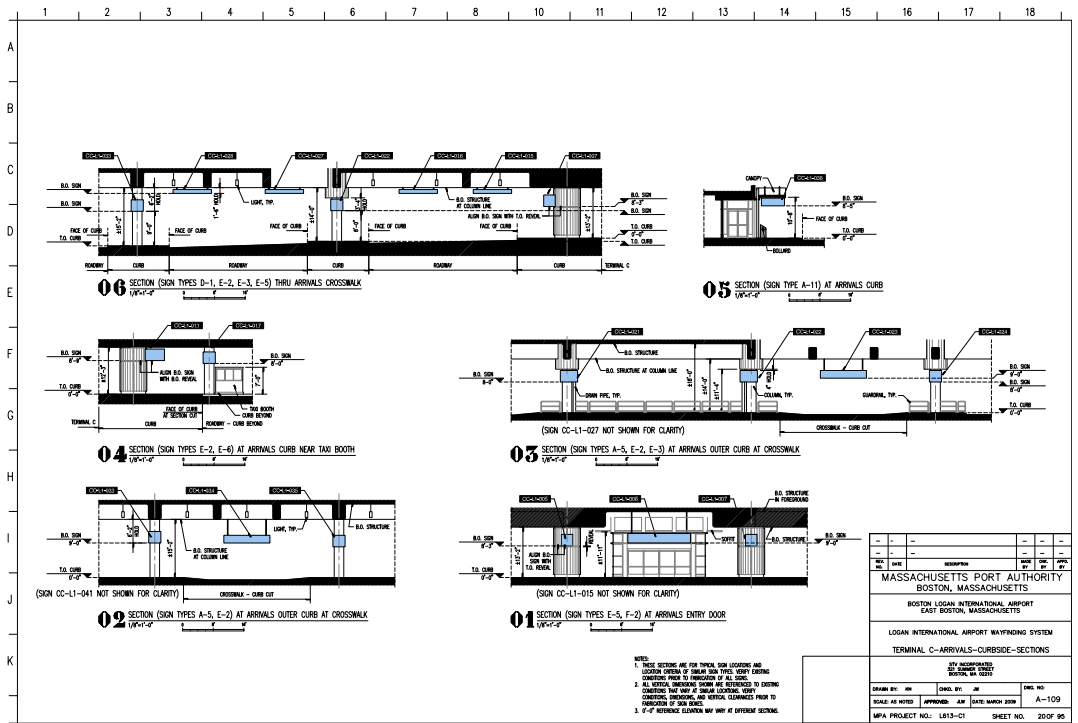

Figure 2-j: 60% Design Development - Sections and Elevations

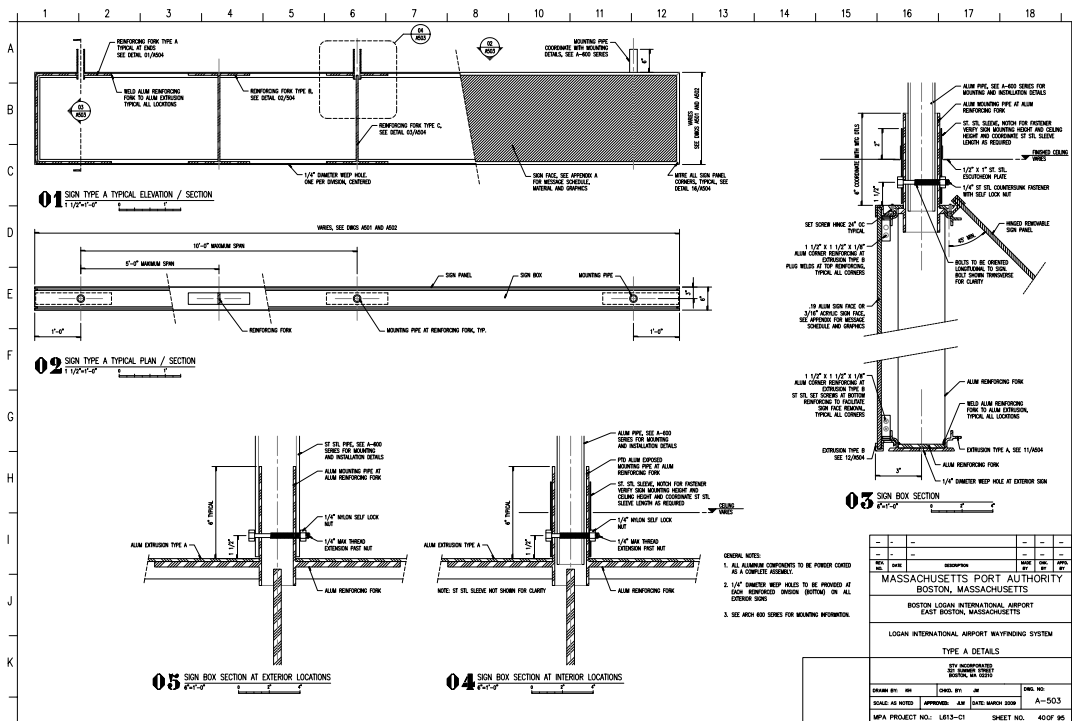

Figure 2-k: 60% Design Development - Typical Details



## SECTION 2 WAYFINDING METHODOLOGY

Logan International Airport Wayfinding System  
Message Schedule

Sign Number	Sign Box Type	Sign Face Type	Size (L x H)	Message - Side A	Message - Side B	Material
TC-L2-001	B-3	ST-107	18'-0" x 0'-0"	← <SYM 'A'> <SYM 'B'> Terminals ↑ <SYM> Restroom Hair and Nail Salon <SYM> ↑		applied vinyl on acrylic
TC-L2-002	B-2	ST-102	12'-0" x 0'-0"	↑ <SYM 'E'> Terminal <SYM> Baggage Claim <SYM> Ground Transportation	Gates C11-C21 <SYM> →	applied vinyl on acrylic
TC-L2-003	A-2	ST-108	12'-0" x 0'-0"	← <SYM> Gates C11-C21	Gates C11-C22 <SYM> →	applied vinyl on acrylic
TC-L2-004	A-3	ST-107	18'-0" x 0'-0"	← <SYM 'A'> <SYM 'B'> Terminals ← <SYM> Elevator Limos <SYM> ↑	← <SYM> Gates C11-C21 Gates C11-C22 <SYM> →	applied vinyl on acrylic
TC-L2-005	A-2	ST-108	12'-0" x 0'-0"	↑ <SYM 'A'> <SYM 'B'> Terminals	↑ <SYM> Gates C11-C36 Ticketing <SYM> ↑	applied vinyl on acrylic
TC-L2-006	A-2	ST-108	12'-0" x 0'-0"	↑ <SYM> Gates C40-C42	↑ <SYM> Gates C11-C36 Ticketing <SYM> ↑	applied vinyl on acrylic
TC-L2-007	A-1	ST-109	6'-0" x 0'-0"	↑ <SYM 'A'> <SYM 'B'> Terminals	↑ <SYM 'C'> <SYM 'E'> Terminals	applied vinyl on acrylic
TC-L2-008	A-2	ST-108	12'-0" x 0'-0"	← <SYM> Elevator <SYM 'A'> <SYM 'B'> Terminals ↑	↑ <SYM 'C'> <SYM 'E'> Terminals Elevator <SYM> →	applied vinyl on acrylic

Note: <SYM> indicates symbol.

**Figure 2-1: 60% Design Development - Draft Message Schedule**

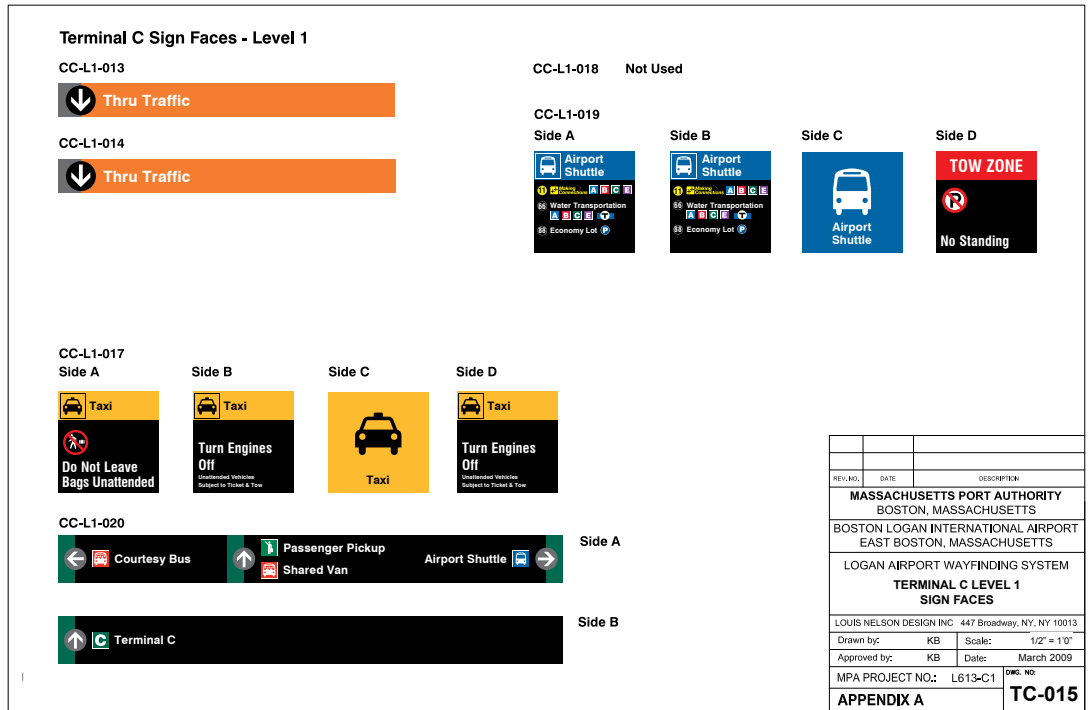
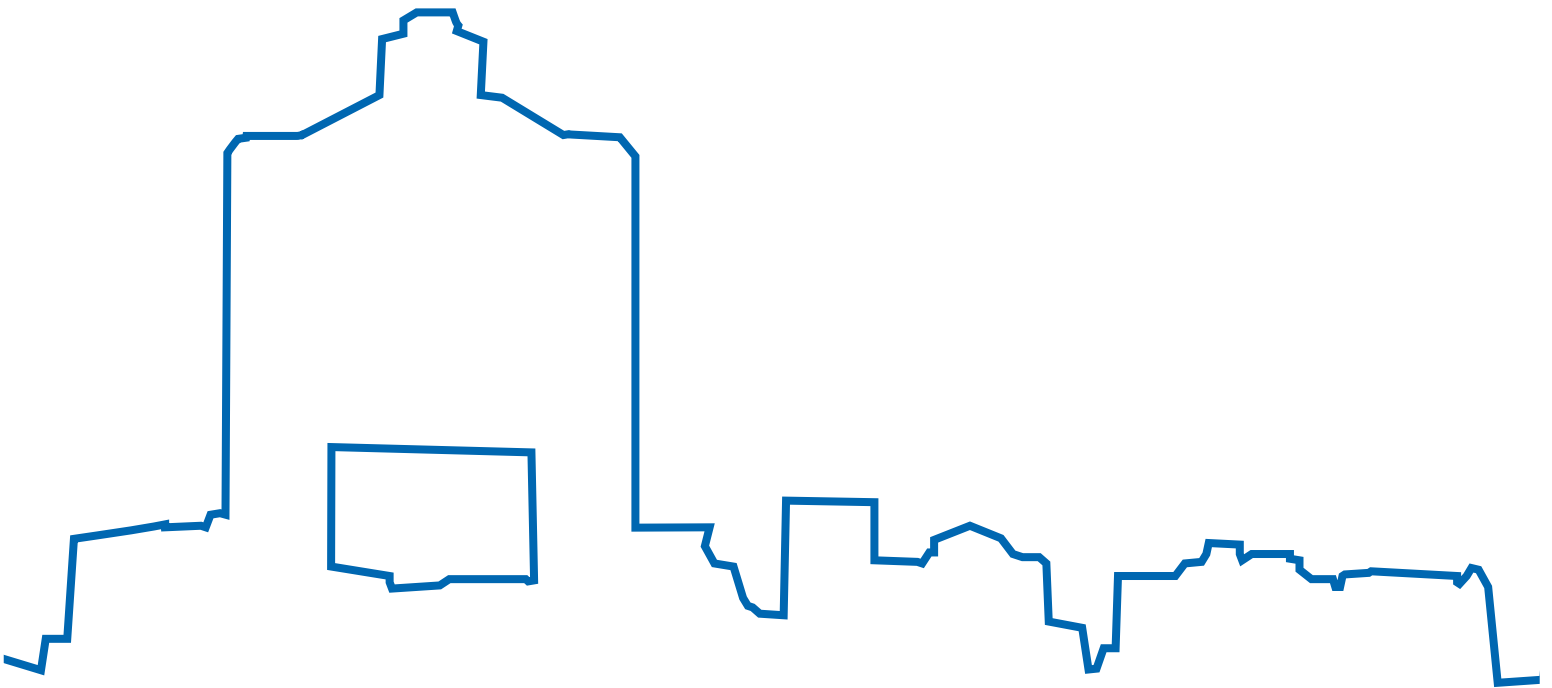

Figure 2-m: 60% Design Development - Typical Sign Faces



## **Section 3**

Design Principles &  
Graphic Standards



### 3.1 WAYFINDING SIGNAGE SYSTEM OVERVIEW

There are four types of wayfinding signs used at Massport airports:

**Directional signs** are used to facilitate circulation to and from a specific destination within the airport complex. These messages are the main information source that enables users to choose the proper route to a specific destination.

**Identification signs** are used to identify specific areas or spaces within the airport complex. These messages mark primary destinations such as terminals, gates, ticketing, and baggage claim locations.

**Informational signs** provide specific and supplementary information about airport services and functions. This includes directories, ground transportation information, airport services, and airline listings.

**Regulatory signs** relate to Federal Aviation Administration (FAA) and Transportation Security Administration (TSA) requirements and recommendations as well as other federal, state, and city regulations. In general, these messages provide passengers with travel advice, warnings, and legal restrictions.

Signs are either non-illuminated or trans-illuminated. The lighting of non-illuminated signs is either through ambient light or direct illumination. Special attention should be taken not to locate signs too close to bright luminaries to avoid glare.

The majority of signs used at Massport airports are to be non-illuminated. Signs located in dark or backlit areas should be trans-illuminated. Directional signs at critical decision points and identification signs of major destination points may also be trans-illuminated. Overhead directional signs at roadways are non-illuminated with direct illumination. Messages that are subject to frequent changes, such as airline listings, should use a programmable variable message system (VMS).

Reflective vinyl shall be used at all roadway signs and shall comply with reflectivity requirements in the Manual on Uniform Traffic Control Devices (MUTCD).

### 3.2 DESIGN PRINCIPLES

The wayfinding signage system should be designed to be clear, comprehensive, and consistent.

#### Legibility

Legibility is an important factor of a successful wayfinding signage system. Legibility is defined as the recognition of the various elements that make a message or symbol understandable without the aid of additional wording or preconditioning. Many of the factors affecting legibility include sign placement, lighting, and color contrast.

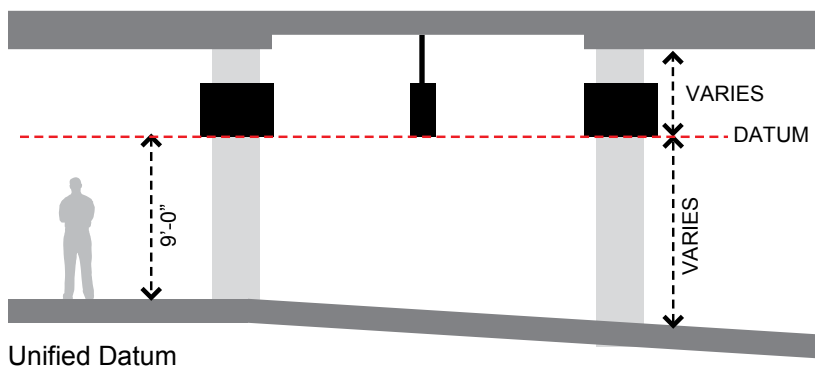

Consistency in placement and presentation of messages, as well as consistent mounting datum and sign sizes, are important factors when addressing legibility. This will minimize the unintended interpretation of the pathways and uses of the facility. The sign location will dictate the range of visibility available for the viewer to interpret the information. If the viewer is given the appropriate distance to comprehend the messages, he or she will be able to make a decision to either change direction or stay on the same pathway. It is also necessary to create a consistent size for text and symbols throughout the facility. This will create a consistent display of information which, in turn, will make interpretation and comprehension easier.



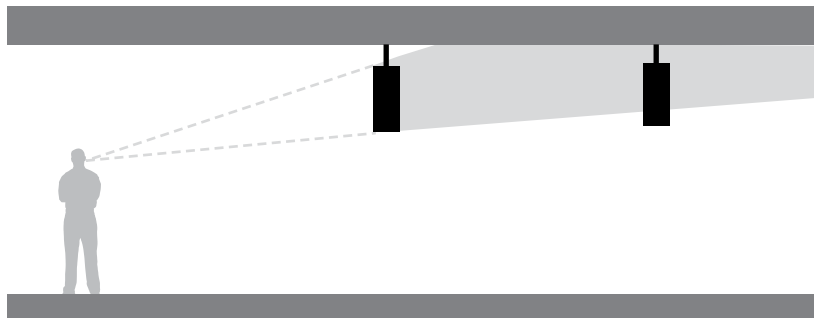

Sign Shadowing

### Language

All messages on wayfinding signs are to be written in English, with the exception of the Message Translation Program implemented at the International Terminal.

### Nomenclature

The same message terms are to be consistently used throughout the wayfinding signage system. See “Message Nomenclature, Priority, and Placement Chart” for a full list of terms approved by Massport.

### Punctuation Marks

The ampersand (&) is used to indicate two related messages. The use of the word “and” is not to be used:

- Baggage Claim A & B
- Food & Beverage
- Ticketing & Gates
- Taxi & Limos

The comma (,) to separate a series is not to be used. A space should be provided before and after elements in a series:

- Baggage Claim B C & D

The hyphen (-) is to be used for a continuous series. No spaces are to be provided before and after the hyphen when used for a continuous series.

- Gates B30-B36

The hyphen is also used for specific messages. A space is to be provided before and after the hyphen in this situation.

- Rental Car - Blue Line

The slash (/) is used for combining messages when space is limited and messages need to be combined on a single line. Consideration shall be taken to combined related messages for this situation:

- Air Canada / PenAir
- Shared Van / Courtesy Bus

The word “and” is reserved for specific messages, such as:

- Lost and Found

### Capitalization

To increase readability, all messages shall be in "Title Case" where the first letter of each word is in uppercase followed by all lowercase letters. All words shall be capitalized except for articles, prepositions, and conjunctions.

Exceptions include all tactile messages which shall be in all uppercase as required by the Americans with Disabilities Act. Additional exceptions include special decorative uses, certain regulatory signs, and specific messages such as the following:

- EXIT
- DO NOT ENTER
- LEFT TURN ONLY
- RIGHT TURN ONLY

Messages of abbreviated names shall also be written in all uppercase:

- ATM
- TDD
- USO

### Message Priority and Placement

Massport designates prioritized messages based on destination priorities. Separate signs for each type of message should be provided.

Primary, Secondary, and Tertiary messages are defined as follows:

- **Primary messages** indicate major airport functions.  
Examples: Terminals and Ground Transportation.
- **Secondary messages** indicate auxiliary services and support functions, and generally supplement information conveyed by primary messages.  
Examples: Restrooms and Concessions
- **Tertiary messages** generally indicate airport safety and warning information. All regulatory signs are considered to be tertiary messages.

If there is a need to place a secondary message on a primary message sign, its importance or order on the sign should always be below primary messages. When multiple messages are included on the same sign, their order on the sign is to be consistent throughout the wayfinding signage system. Message order is based on destination priorities, as shown in the following charts:

**Message Nomenclature, Priority, and Placement Chart**

**Inbound Roadways**

Primary Messages	Secondary Messages
Terminal(s) (A, B, C, etc.)	<i>Secondary messages are prioritized by proximity to the destination.</i>
Airlines	Airport Exit
Arrivals	Boston
Departures	Buses
Central Parking	Cargo Area
Rental Car Center	Cargo Building
	Cell Phone Lot
	CNG Station
	Economy Lot
	Embassy Suites
	Exit
	Fire Rescue
	Fuel
	Fuel/Food
	Gas Station
	General Aviation
	Govt. Center
	Harborside Drive
	Highway Entrance
	Hilton Hotel
	Hyatt Hotel
	International Arrivals
	Limos
	Logan Office Center



**Inbound Roadways - Continued****Primary Messages****Secondary Messages**

Lot 1

Lot 2

Mass Pike

MassDOT - Aviation Division

Massport Administration

Medical Service

No Entry

North Cargo

North Gate

Off-airport Parking

Parking

Parking Entrance

Rental Car Returns

Reserved Tenant Parking

Return to Airport

Return to Parking

Return to Terminals

Revere

South Cargo

State Police Parking

Sumner Tunnel

Taxi

Ted Williams Tunnel

Valet Parking

Visitor Parking

Welcome to Boston Logan International Airport

Welcome to L.G. Hanscom Field

Welcome to Worcester Regional Airport

**Outbound Roadways****Primary Messages**

Terminal(s) (A, B, C, etc.)  
 Boston  
 Central Parking  
 Airport Exit  
 Rental Car Center

**Secondary Messages**

*Secondary messages are prioritized by proximity to the destination.*

Airlines  
 Arrivals  
 Buses  
 Cargo Area  
 Cargo Building  
 Cell Phone Lot  
 CNG Station  
 Departures  
 Economy Lot  
 Embassy Suites  
 Exit  
 Fire Rescue  
 Fuel  
 Fuel/Food  
 Gas Station  
 General Aviation  
 Govt. Center  
 Harborside Drive  
 Highway Entrance  
 Hilton Hotel  
 Hyatt Hotel  
 International Arrivals  
 Limos  
 Logan Office Center  
 Lot 1  
 Lot 2  
 Mass Pike  
 MassDOT - Aviation Division  
 Massport Administration  
 Medical Service

**Outbound Roadways, Continued**

**Primary Messages**

**Secondary Messages**

- No Entry
- North Cargo
- North Gate
- Off-airport Parking
- Parking
- Parking Entrance
- Rental Car Returns
- Reserved Tenant Parking
- Return to Airport
- Return to Parking
- Return to Terminals
- Revere
- South Cargo
- State Police Parking
- Sumner Tunnel
- Taxi
- Ted Williams Tunnel
- Valet Parking
- Visitor Parking
- Welcome to Boston Logan International Airport
- Welcome to L.G. Hanscom Field
- Welcome to Worcester Regional Airport

**Terminals & Curbsides - DEPARTURES LEVEL**

<b>Primary Messages</b>	<b>Secondary Messages</b>
Ticketing	<i>Secondary messages are prioritized by proximity to the destination.</i>
Airlines	
Security Checkpoint	Airline Lounge
Gate(s) (A1, B1, C2; 1, 2, 3; ect.)	Arrivals
All Gates	ATM
Terminal(s) (A, B, C, etc.)	Baggage Carts (Smarte carts)
Walkway to Terminals	Baggage Claim
Elevator	Barber Shop
EXIT	Central Parking
NO ENTRY	Chapel
	Check-in
	Concessions
	Connecting Flights
	Crosswalk (pedestrians crossing)
	Curbside Check-in
	Currency Exchange
	Departures
	Designated Smoking Area
	Duty Free
	Escalator
	Food & Beverage
	Ground Transportation
	Hilton Hotel
	Information
	Kid Port
	Level (1, 2, 3, 4 etc.)
	Limos
	Lost and Found
	Mailbox
	Men's Restroom
	Parking Violations
	Passenger Drop-off
	Pet Port



**Terminals & Curbsides - DEPARTURES LEVEL, Continued**

**Primary Messages**

**Secondary Messages**

- Police
- Public Transportation
- Restrooms
- Salon
- Shoe Shine
- Smoking Area
- Staff Only
- TDD Telephone
- Telephone
- USO
- Women's Restroom

**Terminals & Curbsides - ARRIVALS LEVEL**

<b>Primary Messages</b>	<b>Secondary Messages</b>
Terminal(s) (A, B, C, etc.)	<i>Secondary messages are prioritized by proximity to the destination.</i>
Walkway to Terminals	
Central Parking	ATM
Baggage Claim	Baggage Carts (Smarte carts)
Public Transportation	Baggage Recheck
Ground Transportation	Barber Shop
Elevator	Chapel
USO	Check-in
Airport Shuttle	Concessions
Rental Car - Blue Line	Connecting Flights
Passenger Pickup	Currency Exchange
Taxi	Customs
Limos	Departures
Courtesy Bus	Designated Smoking Area
Shared Van	Escalator
Silver Line	EXIT
Logan Express	Food & Beverage
Scheduled Bus	Gate(s) (A1, B1, C2; 1, 2, 3; ect.)
Charter Bus	Hilton Hotel
International Arrivals	Hotel Information
Domestic Arrivals	Immigration
Baggage Service Offices	Information
US Customs & Border Protection	Level (1, 2, 3, 4 etc.)
Smoking Area	Lost and Found
Parking Violations	Mail Box
NO ENTRY	Meeting Point
	Men's Restroom
	Oversized Baggage
	Pet Port
	Police
	Restrooms
	Security Badges
	Staff Only



**Terminals & Curbsides - ARRIVALS LEVEL, Continued**

**Primary Messages**

**Secondary Messages**

TDD Telephone

Telephone

Ticketing

Women's Restroom

xPress Pay Parking

(Messages not included require review and approval from Massport). The same message may fall under a different category depending on its use or location. For example, the term "Ticketing" is considered a primary message in the Terminals -Departure Level, but is considered a secondary message in the Arrivals Level.

**Sign Size**

The size of a sign is determined by the length of the message and the physical restraints of the space in which it is placed. Overhead wayfinding signs shall be designed with lengths in increments of 6 feet and heights as shown in the following diagram. This allows the sign to be re-messaged or used for a different sign type in the future. Additional sign size requirements are shown in Section 5.

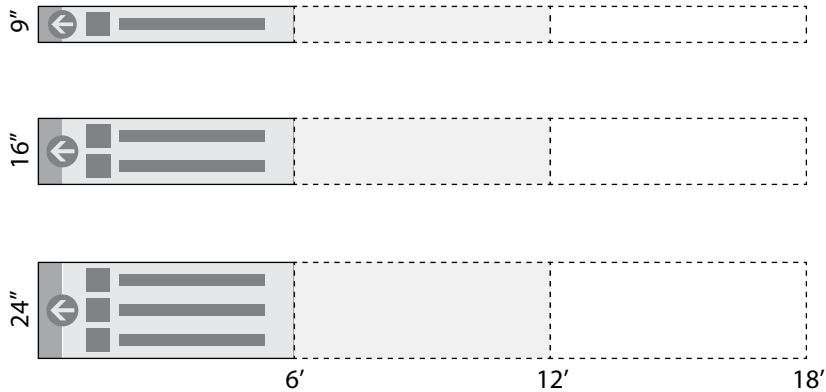

It should be noted, that it is preferred not to have more than three directions of travel on one sign. If additional destinations are required, additional signs shall be provided.

When a series of signs are located in the same area, it is preferred that they be the same length regardless of the message. This will help maintain a systematic and cohesive look throughout the airport.

The size of certain signs should be designed to the physical space in which they will be placed. For example, a destination sign located above an entryway should be sized to the opening and may not be the same size as the signs located. This will emphasize the location as a destination.

All sign dimensions specified within this document refer to exposed visual face dimensions. Frame (overall) and panel (actual) dimensions are not included.

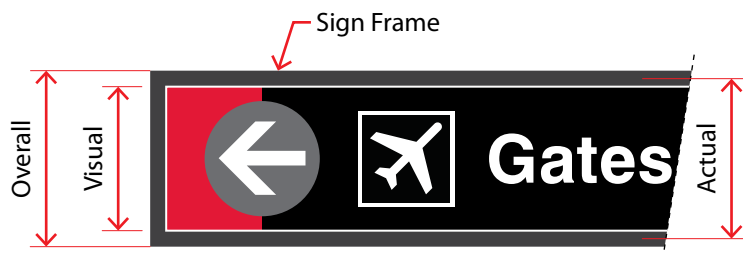

### 3.3 GRAPHIC STANDARDS

The following graphic elements should be used for the design of new and modified wayfinding signage.

#### Font Type

The typeface used throughout the wayfinding signage system is a consistent version of Swiss 721. There are four font types used within this family:

##### Swiss 721 Bold BT

Swiss 721 Bold BT is the standard font for all text on both interior and exterior wayfinding signs and shall be used for the majority of the messages.

**ABCDEFGHIJKLMNOPQRSTUVWXYZ  
abcdefghijklmnopqrstuvwxyz  
1234567890.:,;(:\*!?)**

##### Swiss 721 Black BT

Swiss 721 Black BT is the standard font used for the letters in the Terminal Identification Icon symbols. Additional uses for Swiss 721 Black BT include the Terminal designation letter and floor number found on Elevator Directory signs (ST-181) and the letters that identify the gates in the Gate ID Airline Listing signs (ST-153). See Section 5 for uses.

**ABCDEFGHIJKLMNOPQRSTUVWXYZ  
abcdefghijklmnopqrstuvwxyz  
1234567890.:,;(:\*!?)**

**Swiss 721 Black Condensed BT**

Swiss 721 Black Condensed BT is the standard font used for select text on regulatory messages and for select text on the Pedestrian Entry Door Building Identification signs at Service Buildings (ST-553). See Section 5 for uses.

**ABCDEFGHIJKLMNOPQRSTUVWXYZ****abcdefghijklmnopqrstuvwxyz****1234567890.:,;(:\*!?'')****Swiss 721 Bold Condensed BT**

Swiss 721 Condensed BT is the standard font used for the level numbers on the Parking Level ID Pylon signs (ST-366). See Section 5 for uses.

**ABCDEFGHIJKLMNOPQRSTUVWXYZ****abcdefghijklmnopqrstuvwxyz****1234567890.:,;(:\*!?'')**

Swiss 721 Black BT, Swiss 721 Black Condensed BT, and Swiss 721 Bold Condensed BT are considered specialized type styles and should be used exactly as shown in Section 5.

Fonts, weights, or type styles not described above should not be used. No modification of character shape is permitted unless specified in the graphic standards or on the sign type layout. Bolded, condensed, extended, slanted, italicized, outlined, or otherwise distorted type shall also not be used.

**Font Size**

The standard cap-height or font size for messages on wayfinding signs at Massport airports varies by sign type and location. In general, the recommended minimum cap-height for pedestrian wayfinding signs is 3" and the recommended cap-height for vehicular wayfinding signs is 12" at roadways, 6" at terminal curbsides, and 3" at parking areas. For critical interior pedestrian wayfinding signs where ceiling heights allow, the preferred cap-height is 6". For informational signs, such as directories and room IDs, the recommended cap-height is 1". See Section 5 for additional cap-height sizes.

Cap-height shall be measured from the baseline to the top of a standard uppercase letter, such as the letter “X”. In some cases, parts of a character may fall above the top of the standard capital letter or below the baseline, such as rounded numbers or letters, or the lowercase letter “y” and will slightly exceed the standard cap-height.

For better legibility, lowercase letters shall have a lowercase x-height that is 2/3 the height of the uppercase letter. The x-height of a font is the distance between the baseline of a line of type and the top of the main part of the lowercase letter.

### Letter Spacing

To enhance readability, all messages shall have an approximate 105% tracking on interior signs and 110% tracking on exterior signs. Tracking refers to the adjustment of space between individual characters of an entire word. In the event that a message is too lengthy for a sign, the message shall be broken into two lines of text. No reduction of letter spacing is permitted.

### Word Spacing

Word spacing is the distance between related words. Space between related words shall be approximately 3/4 the letter cap-height. For example, a message with a 3” cap-height will have a 2 1/4” space between words. In the event that a message is too lengthy for a sign, the message should be broken into two lines of text or a shortened message, approved by Massport, may be used. No reduction of word spacing is permitted.

$\frac{3}{4}x$  → | ←  
x | **Baggage Claim**

### Line Spacing

The following diagrams illustrate the standard object spacing and location for an overhead directional sign at Terminals and Curbsides. The same methodology and relationships are to be applied to other sign types and locations throughout the airport. It should be noted that for overhead roadway directional signs, the arrow and banding is to be located at the bottom of the sign. For roadside directional signs, the arrow and banding is to remain left and right justified.

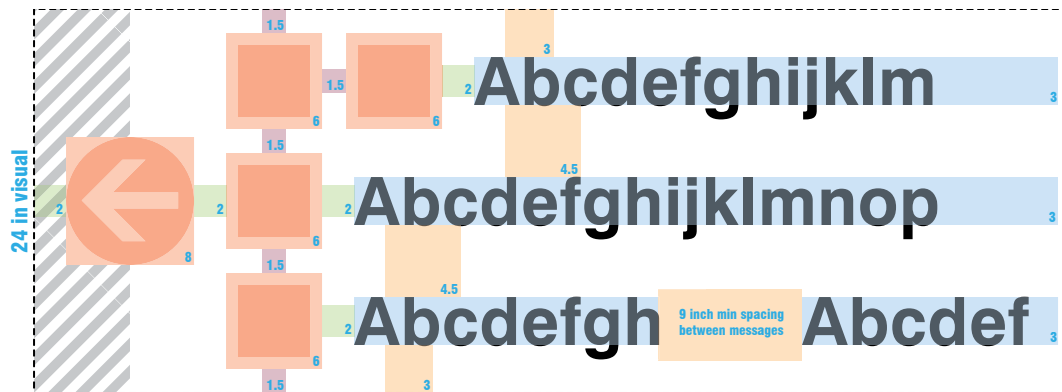

#### 3-Line Overhead Sign

The minimum horizontal spacing shown between messages is to be used for all signs.

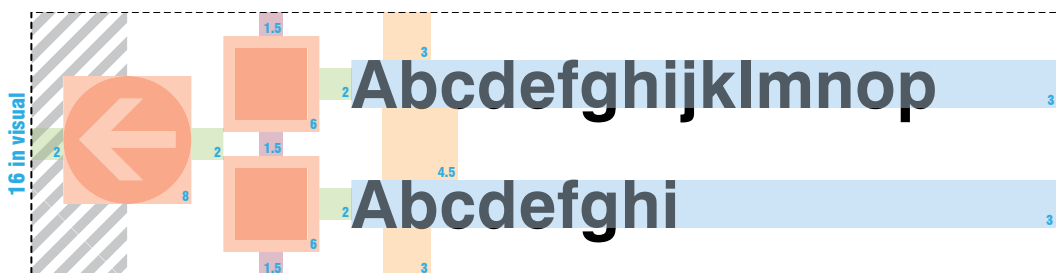

#### 2-Line Overhead Sign



#### 1-Line Overhead Sign

The dimension of the arrow is reduced to 7 inches on a 1-Line Overhead sign. Size and spacing shown for the Blue Line T and Silver Line T symbols are to be used for all signs.



The following diagrams illustrate the standard object spacing and location for a standard directional sign with a divider line (rule line). These signs are used for messages that need to be stacked vertically due to horizontal constraints.



**3-Line Sign with Rule Line**

The dimension of the arrow is reduced to 7 inches in both 3-line and 2-line signs to allow appropriate spacing from the arrow to the edge of the sign face.

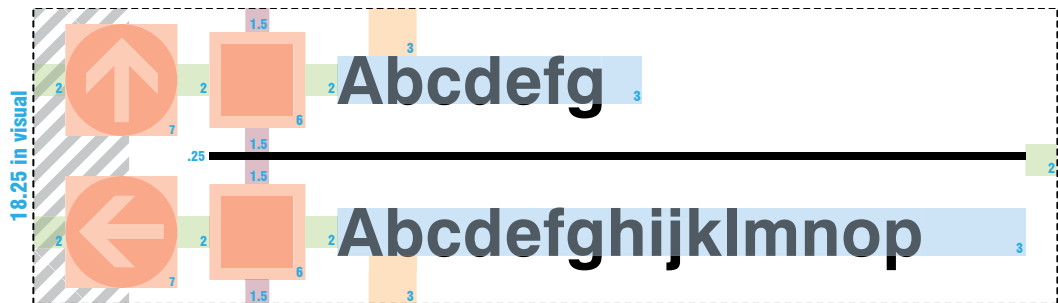

**2-Line Sign with Rule Line**

The following diagrams illustrate how to include a second line of related text such as messages in a series, or splitting messages into two lines of text due to horizontal constraints.



**2-Line Sign with Related Text Below**

The arrow for this sign is to be centered with the symbols and not the sign face.



**1-Line Sign with Related Text Below**

The dimension of the arrow is reduced to 7 inches to allow appropriate spacing from the arrow to the top of the sign face. Similar to the 2-line sign, the arrow is to be centered with the symbol of the first line of text and not the sign face.

The following series of diagrams illustrate how to include supporting text within a sign face. Supporting text is used to clarify a message, or provide specific directions to the reader.



***2-Line Sign with Supporting Text for Each Message***

This layout is used for a 2-line sign where each message requires supporting text that is different from one another. The arrow for this series of sign faces is to be centered with the symbols and not the sign face. As a general rule supporting text should be avoided.



***2-Line Sign with Supporting Text for Both Messages***

This layout is used for a 2-line sign where the supporting text applies to both messages. The supporting text is aligned to the symbols and not to the above message. As a general rule supporting text should be avoided.

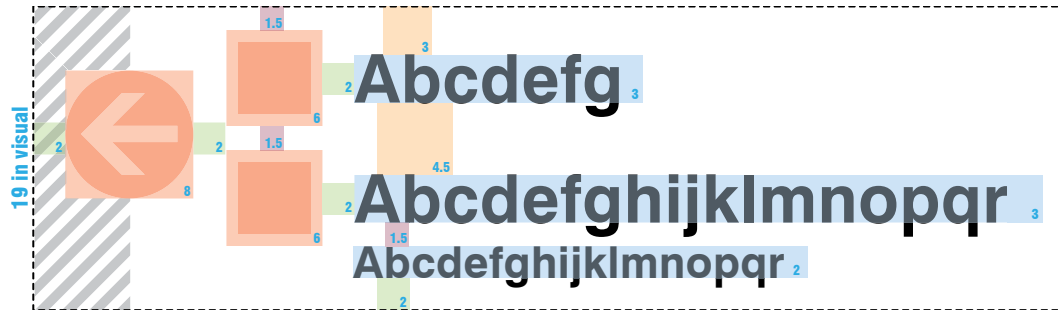

**2-Line Sign with Supporting Text for One Message**

This layout is used for a 2-line sign where only one of the messages requires supporting text. As a general rule supporting text should be avoided.



**1-Line Sign with Supporting Text**

This layout is used for a 1-line sign where the message requires supporting text. The dimension of the arrow is reduced to 7 inches to allow appropriate spacing from the arrow to the top of the sign face. As a general rule supporting text should be avoided.

When the height of a sign is limited by physical constraints, such as low ceiling heights, object spacing and symbol sizes need to be adjusted. The following diagrams illustrate how to adjust the standard overhead directional sign. As a rule of thumb, the priority for reducing the size of the sign is to reduce the symbol size, which allows spacing to be decreased. Under no circumstance should the symbols be smaller than the message cap-height.

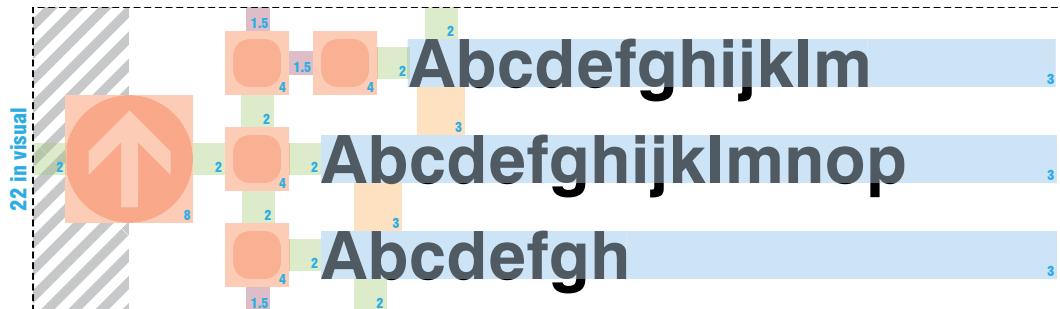

#### ***3-Line Sign Adjusted with Reduced Symbols***

The dimension of the symbols are reduced from 6 inches to 4 inches. The spacing between messages are reduced from 4.5 inches to 3 inches.

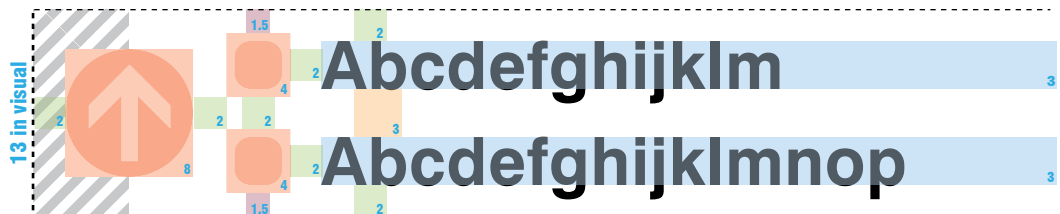

#### ***2-Line Sign Adjusted with Reduced Symbols***

As with the 3-Line Adjusted with Reduced Symbols Sign, the dimension of the symbols are reduced from 6 inches to 4 inches. The spacing between messages are reduced from 4.5 inches to 3 inches.

The following diagram illustrates how to include a header band to a standard overhead directional sign. The same methodology is to be applied to 2-line and 1-line signs.

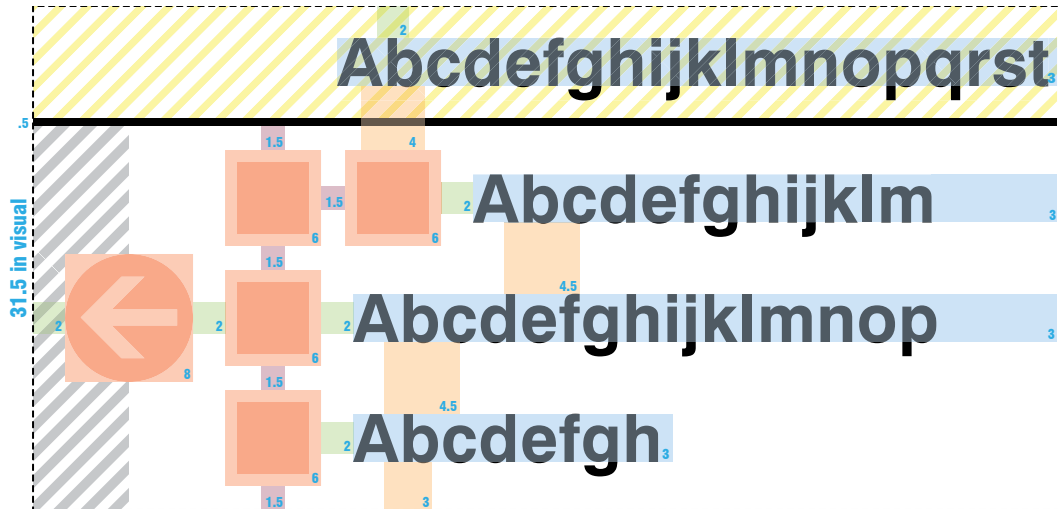

*3-Line Sign with Header*

The following diagrams illustrate the standard object location and spacing for a flag or column mounted directional sign at Terminal curbsides. These signs are typically one directional with a listing of different modes of ground transportation. Sizes and spacing of objects are reduced to accommodate the size of these signs. The same methodology is to be applied to signs with fewer lines of messages.

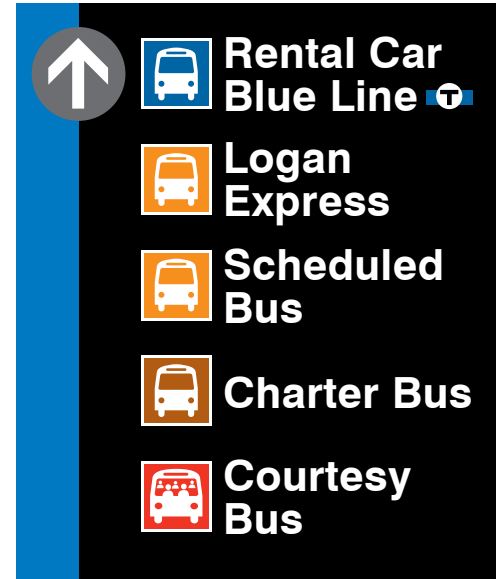

***Flag Mounted Curbside Directional 5-Line Sign***

The spacing between symbols are increased from 1.5 inches to 2.25 inches to accommodate messages with related text.

The following diagram illustrates the standard object location and spacing for a room ID sign. The lower panel is optional and contains asset management information. The top panels room number is terminated by the project requirements. If required the length of the sign can be increased to fit longer messages.

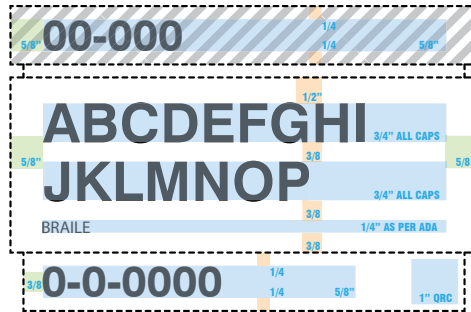

**Wall Mounted Room ID Sign**

The spacing between symbols are increased from 1.5 inches to 2.25 inches to accommodate messages with related text.



### Arrow Symbols

Arrow symbols are used on all directional wayfinding signage to convey a direction graphically. The standard arrow symbol is a white arrow fixed within a gray or black circle. A gray circle is used on pedestrian directional signs located at the following except in Parking Areas. A black circle is used on pedestrian directional signs in Parking Areas:

- Terminals
- Curbsides
- Parking Areas

A black circle is used on vehicular directional signs located at:

- Airport Roadways
- Curbsides
- Parking Areas
- Service Buildings

### Arrow Orientation









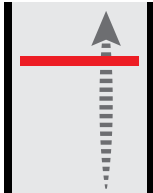

The orientation that arrow symbols convey should be consistent on the wayfinding signage system at Massport airports. The standard arrow symbol can be rendered in nine different orientations for pedestrian movement and six different orientations for vehicular movement. The orientation should be aligned to reflect the user circulation flow. No alternate orientations are permitted unless approved by Massport.

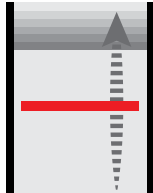
### Arrow Placement

The position of the arrows on the sign are to be placed to be consistent with the direction of travel being specified and are never to point into its message. For example, arrows pointing to the right are to be located on the right side of the sign; and arrows pointing to the left are to be located on the left side of the sign. For signs indicating one direction of travel where the arrow can be located on either the right or left side, it is preferred that the arrow be located on the left side of the sign. Arrow symbols may be located on the right side of the sign only if users should be encouraged to keep right.

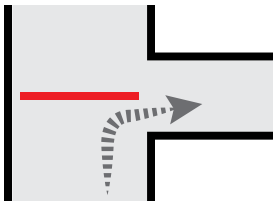

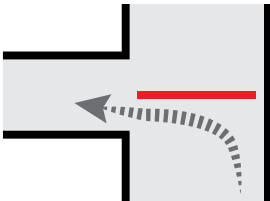

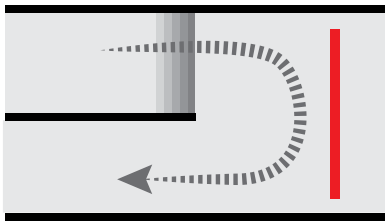

For signs indicating three directions of travel, the arrow symbol location for the middle portion of the sign face may be right or left justified depending on the direction of travel specified for that message.

**Pedestrian Arrow Symbol Applications**

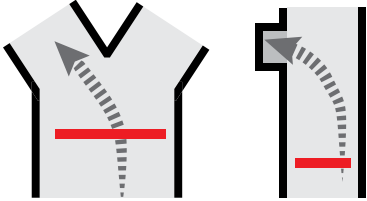
ARROW ORIENTATION	EXAMPLE PLAN	INTERPRETATION
		Straight Ahead
		Straight Ahead and Up
		Straight Ahead and Down
		Turn Right
		Turn Left
		Turn Around

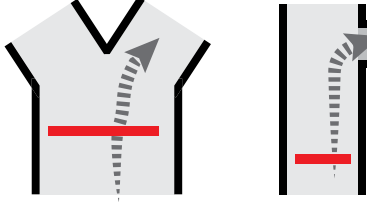

U-turn arrows (turn around) are used to reverse the direction of travel 180-degrees. This arrow is discouraged and is only to be used sparingly when no other option exists.

*Pedestrian Arrow Symbol Applications*





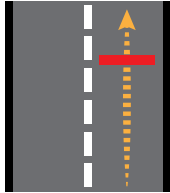
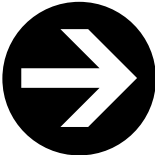
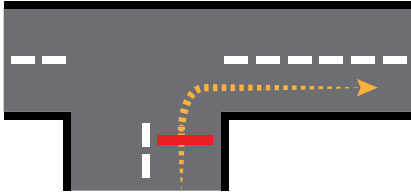

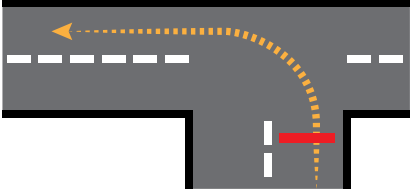
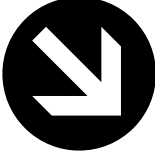
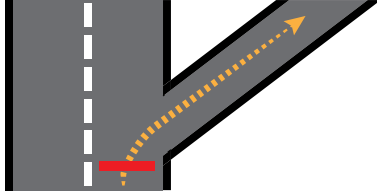
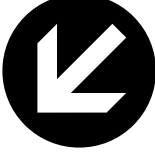
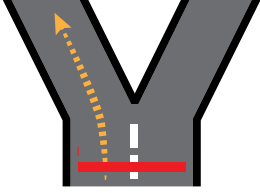
ARROW ORIENTATION	EXAMPLE PLAN	INTERPRETATION
		<p>Staight Ahead on the Left</p>
		<p>Staight Ahead on the Right</p>
		<p>To the Left and Down</p>
		<p>To the Right and Down</p>

45-degree arrow symbols for pedestrian movement can be used to indicate a route that is ahead on the left or right; however, it is preferred to separate the message into two separate signs. For example, when one sign directing users straight ahead and a second sign is directing users to the left or right.

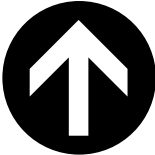
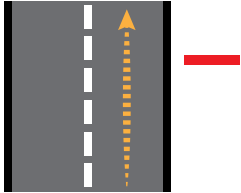
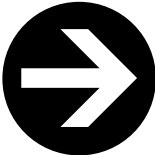
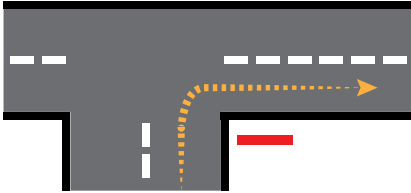
*Overhead Vehicular Arrow Symbol Applications*

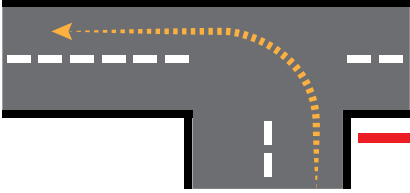
ARROW ORIENTATION	EXAMPLE PLAN	INTERPRETATION
		Straight Ahead
		Right Turn
		Left Turn
		Exit Right
		Exit Left

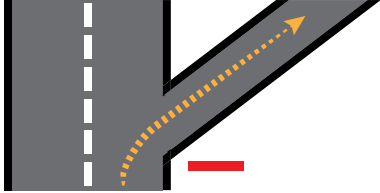
*Roadside Vehicular Arrow Symbol Applications*

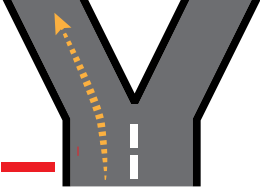
ARROW ORIENTATION	EXAMPLE PLAN	INTERPRETATION
		Straight Ahead
		Right Turn
		Left Turn
		Exit Right
		Exit Left

It should be noted, the arrow symbol used to convey a direction that is straight ahead varies for pedestrian signs and vehicular signs. Straight-ahead pedestrian movement should be indicated by straight upward-facing arrows, unless a straight downward-facing arrow can be shown to be clearly advantageous in a specific circumstance, such as a message directing users up an escalator on the same sign. It is preferred that straight downward-facing arrows be reserved to indicate movement to a lower level.

Straight-ahead vehicular movement should be indicated by straight downward-facing arrows on overhead signs and by straight upward-facing arrows on free standing roadside directional signs.

Messages for roadway signs are always left justified regardless of the location of the arrow. Symbols either precede the message or are located below the message line. This only occurs on roadway or roadside signs.

### Arrow Symbol Size

The proportion of the diameter of the circle to the length of the arrow is  $\frac{3}{4}$  the diameter of the circle. When specifying the arrow symbol size, the size refers to the circle and not the length of the arrow. To indicate a different direction, the arrow is rotated using the center of the circle as the base point.

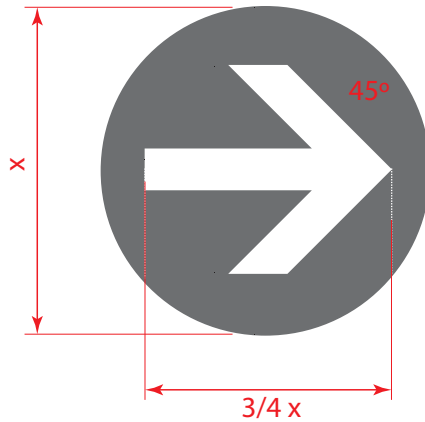

The size of the arrow symbol on directional wayfinding signs at Massport airports should be proportionate to the message cap-height. See Section 5 for arrow sizes.

## Symbols

A variety of international symbols have been selected and approved by Massport for use on wayfinding signs. These symbols are in broad use around the world and are readily identified by the international traveling public. The symbols are used to reinforce and provide visual confirmation of a message as well as assist users who do not read English.

Massport has also established a set of terminal icon symbols used to identify each terminal building that should also be used on wayfinding signs.

## Symbol Size

The symbols are used in a variety of applications and their size varies depending on the type of wayfinding sign. The standard symbol size on directional wayfinding signs is proportionate to the cap-height of its corresponding message. All symbols should be 2 times the cap-height on pedestrian signs and vehicular roadway signs.

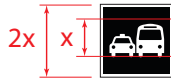

## Ground Transportation

See Section 5 for the size of symbols for informational and identification signs.

## Symbol Placement

For the majority of wayfinding signs, a symbol will always accompany a written message. For messages that are right justified, the symbol is placed to the right of its corresponding text. For messages that are left justified, the symbol is placed to the left of its corresponding text. Messages for roadway signs are always left justified. In some instances, the symbols may be located below the message line. This occurs only on roadway signs.

Symbols are typically not used in conjunction with a variable message system (VMS) line of text.



**Arrow Placement and Symbol Relationship Diagram**

Arrow and symbol relationships for typical directional signage is illustrated below. The vertical justification of a single line message as part of a three line sign varies depending on whether or not it is a one line message or two line message.

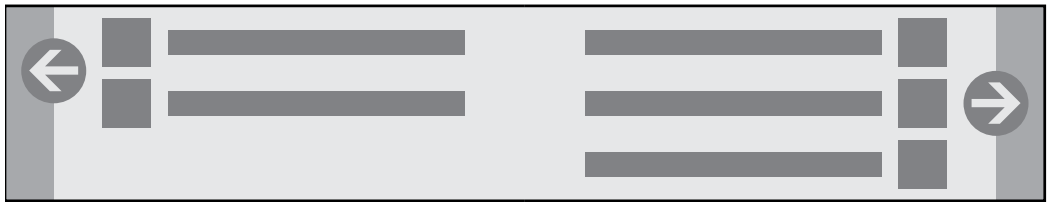
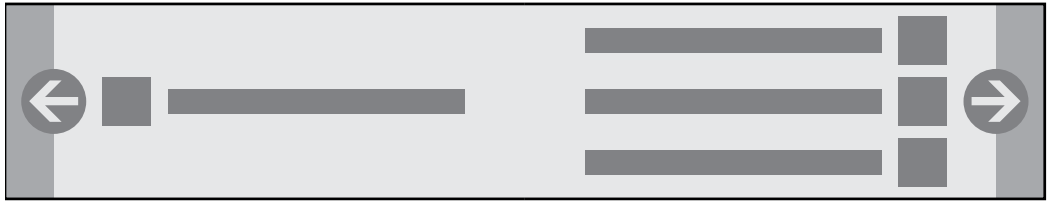

The below diagram illustrates arrow and symbol relationships for typical directional signage with two directions of travel that are stacked vertically due to horizontal constraints. This type of layout should be used sparingly. It is important to note that the relationship of the arrow with multiple messages remains the same for a two-line and three-line message.

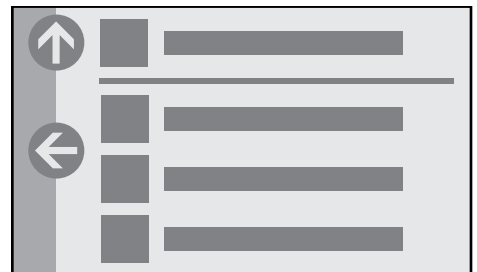
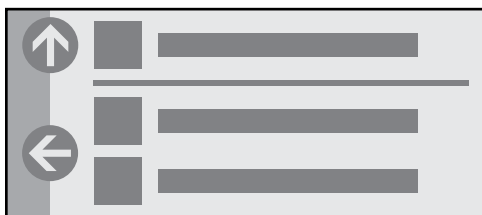
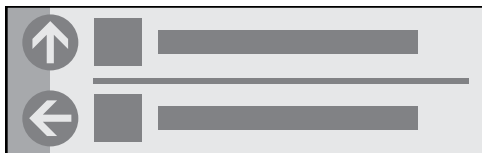

Messages for roadway signs are always left justified regardless of the location of the arrow. Symbols either precede the message or are located below the message line. This only occurs on roadway or roadside signs.

**3.4 COLOR STANDARDS**

**Terminal Icon Symbols and Terminal Identification Colors**

	Terminal A	Terminal B	Terminal C	Terminal E
Color	Blue	Red	Green	Purple
Translucent Pantone	PMS 300 C	PMS 186 C	PMS 356 C	PMS 2593 C
Translucent Vinyl Equivalent	Gerber Translucent #230-157 Cobalt Blue	Gerber Translucent #230-33 Red	Gerber Translucent #230-26 Green	Gerber Translucent #230-128 Plum Purple
Opaque and Reflective Pantone	PMS 300 C	PMS 185 C	PMS 355 C	PMS 2593 C
Opaque Vinyl Equivalent	Gerber Opaque #220-47 Intense Blue	Gerber Opaque #220-293 Atomic Red	Oracal Opaque #951-062 Light Green	Oracal Translucent #880D-403 Light Violet
Reflective Vinyl Equivalent	Translucent Color over reflective white**	Translucent Color over reflective white**	Translucent Color over reflective white**	Translucent Color over reflective white**
Paint Equivalent	MAP Paint to match PMS 300 C	MAP Paint to match PMS 185 C	MAP Paint to match PMS 355 C	MAP Paint to match PMS 2593 C

RCC and Parking Icon Symbols and Identification Colors

	RCC	Parking & Cell Phone Lot Identification
Color	Yellow (Sunflower)	Blue
Translucent Pantone	PMS 123 C	PMS 300 C
Translucent Vinyl Equivalent	Gerber Translucent #230-25 Sunflower	Gerber Translucent #230-157 Cobalt Blue
Opaque and Reflective Pantone	PMS 1235 C	PMS 300 C
Opaque Vinyl Equivalent	Gerber #220, 225-25 Sunflower	Gerber Opaque #220-47 Intense Blue
Reflective Vinyl Equivalent	Translucent Color over reflective white**	Translucent Color over reflective white**
Paint Equivalent	MAP Paint to match PMS 123 C	MAP Paint to match PMS 300 C

Ground Transportation Mode Colors

	Taxi	Scheduled Bus and Logan Express	Charter Bus	Shared Van and Courtesy Bus	Limos
Color	Yellow (Sunflower)	Orange	Terra Cotta	Red	Purple
Translucent Pantone	PMS 123 C	PMS	PMS	PMS	PMS
Translucent Vinyl Equivalent	Gerber Translucent #230-25 Sunflower	Translucent	Translucent	Translucent	Translucent
Opaque and Reflective Pantone	PMS 1235 C	PMS 021 C	PMS 160 C	PMS 1795 C	PMS 259 C
Opaque Vinyl Equivalent	Gerber Opaque #220-25 Sunflower	Gerber Opaque #220-14 Bright Orange	Gerber Opaque #220-24 Terra Cotta	Gerber Opaque #220-13 Tomato Red	Gerber Opaque #220-98 Dark Violet
Reflective Vinyl Equivalent	Translucent Color over reflective white**	Translucent Color over reflective white**	Translucent Color over reflective white**	Translucent Color over reflective white**	Translucent Color over reflective white**
Paint Equivalent	MAP Paint to match PMS 1235 C	MAP Paint to match PMS 021 C	MAP Paint to match PMS 021 C	MAP Paint to match PMS 1795 C	MAP Paint to match PMS 259 C



Ground Transportation Mode Colors

	Rental Car- Blue Line Shuttle	Airport Shuttle	Passenger Pickup	Silver Line
Color	Blue	Blue	Green	Gray
Translucent Pantone	PMS 300C	PMS 300C	PMS	PMS
Translucent Vinyl Equivalent	Gerber Translucent #230-127 Intense Blue	Gerber Translucent #230-157 Intense Blue	Gerber Translucent #230	
Opaque and Reflective Pantone	PMS 301 C	PMS 301 C	PMS 348 C	PMS Cool Gray 2 C
Opaque Vinyl Equivalent	Gerber Opaque #220-47 Intense Blue	Gerber Opaque #220-47 Intense Blue	Gerber Opaque #220-186 Bright Green	Gerber Opaque #220-11 Pearl Gray
Reflective Vinyl Equivalent	Translucent Color over reflective white**	Translucent Color over reflective white**	Translucent Color over reflective white**	Translucent Color over reflective white**
Paint Equivalent	MAP Paint to match PMS 1235 C	MAP Paint to match PMS 021 C	MAP Paint to match PMS 021 C	MAP Paint to match PMS 1795 C



Speciality and Accent Colors

	Regulatory	Caution Red	ADA Blue	Reflective White
Color	Red	Red	Blue	White
Translucent Pantone				
Translucent Vinyl Equivalent				
Opaque and Reflective Pantone	PMS 1795 C	PMS 193 C	PMS 293 C	
Opaque Vinyl Equivalent	Gerber Opaque #220-13 Tomato Red			
Reflective Vinyl Equivalent	3M Reflective Scotchlite #4092 Red	3M Reflective Scotchlite #4092 Red	3M Reflective Scotchlite #4095 Blue	Interior Signs - 3M Reflective Scotchlite #4090 White Roadway Signs - Avery Dennison T-6500 Curbside & Parking - 3M Scotchlite Flexible Reflective Graphic Film 680-10
Paint Equivalent	MAP Paint to match PMS 1795 C			



Background Color Fields

	Standard Pedestrian and Vehicle Wayfinding Signs	Pedestrian Warning and Vehicle Clearance Signs	Parking Pedestrian Directional Signs	Curbside Vehicle Directional Signs
Color	Black	Yellow	Fluorescent Yellow	Fluorescent Orange
Translucent Pantone				
Translucent Vinyl Equivalent				
Opaque and Reflective Pantone		PMS 131 C	PMS 388 C	PMS 1655 C
Opaque Vinyl Equivalent	3M Scotchcal Opaque #7725-12 Black			
Reflective Vinyl Equivalent		3M Reflective Scotchlite #4091 Yellow	3M Reflective Scotchlite #4083 Fluorescent Yellow Green	3M Reflective Scotchlite #4064 Fluorescent Orange
Paint Equivalent	MAP Paint #41-335 Black Anodic			



Text

	Non-Illuminated Text - Curbside/ Parking	Non-Illuminated Text - Roadways	Non-Illuminated Text - Terminal Interior
Color	White	White	White
Translucent Pantone			
Translucent Vinyl Equivalent			
Opaque and Reflective Pantone	<b>Text</b>	<b>Text</b>	<b>Text</b>
Opaque Vinyl Equivalent			Gerber Instachange Removable White
Reflective Vinyl Equivalent	3M 680 Series Reflective White	Avery T6500 White Reflective	
Paint Equivalent			

Arrows, Borders, and Arrow Circles

	Non-illuminated Arrows - Curbside/ Parking	Non-illuminated Arrows - Roadways	Non-illuminated Arrows - Terminal Interior	Borders, Rule Lines, and Arrow Circles
Color	White	White	White	70% Black
Translucent Pantone				
Translucent Vinyl Equivalent				3M Scotchcal Translucent #3630-61 Slate Gray
Opaque and Reflective Pantone				
Opaque Vinyl Equivalent			Gerber Instachange Removable White	Oracal Opaque #951-721 Slate Gray
Reflective Vinyl Equivalent	3M 680 Series Reflective White	Avery T6500 White Reflective		
Paint Equivalent	MAP Paint #42-202 Natural White	MAP Paint #42-202 Natural White	MAP Paint #42-202 Natural White	MAP Paint to match 70% Process Black

**Sign Boxes, Sign Supports, and Sign Structures**

	Sign Boxes *	Sign Supports	Sign Structures
Color	Black	Black	Black
Translucent Pantone			
Translucent Vinyl Equivalent			
Opaque and Reflective Pantone			
Opaque Vinyl Equivalent			
Reflective Vinyl Equivalent			
Paint Equivalent	MAP Paint to match 100% black	MAP Paint to match 100% black	MAP Paint to match 100% black

\* Sign boxes to be painted where indicated in Section 6



## Section 4

### Libraries

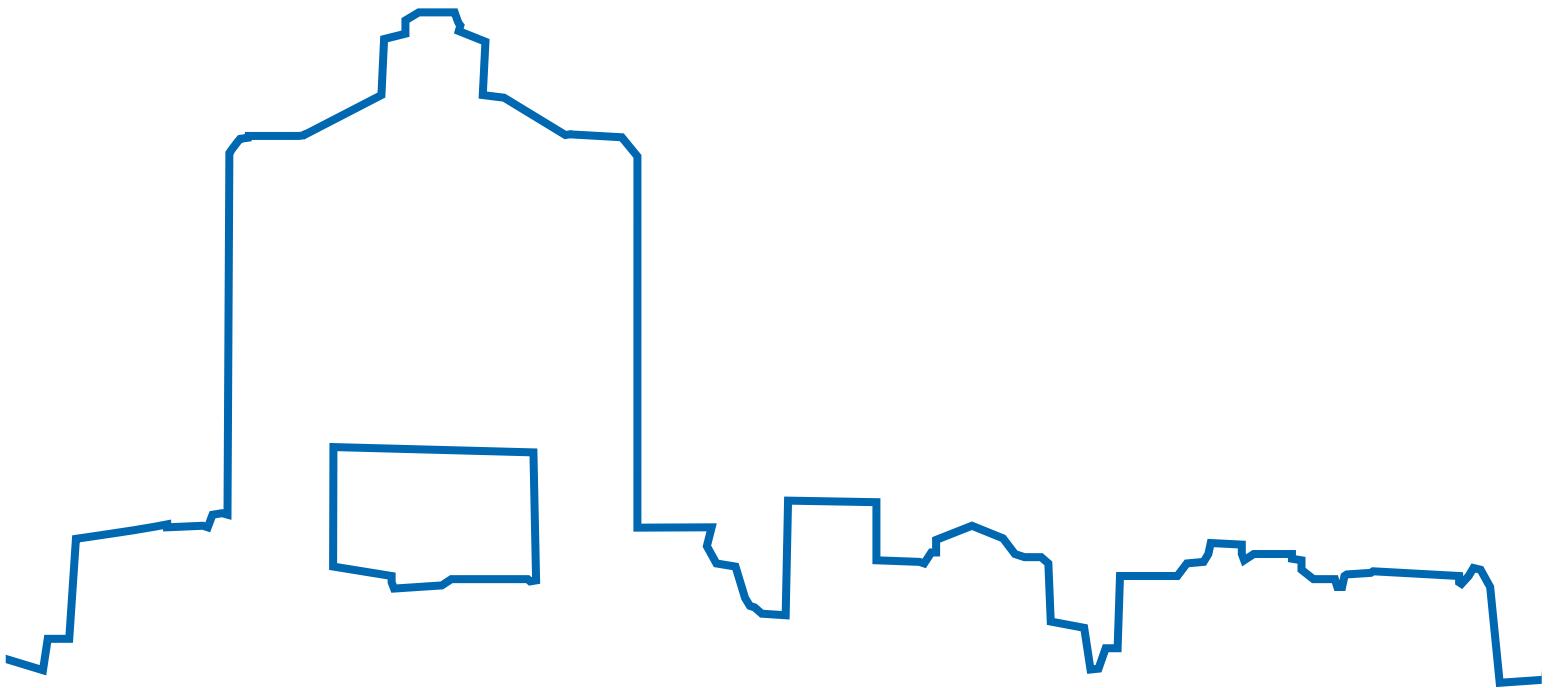





The symbols, arrows, and Massport artwork included within this section are to be used by designers and consultants designing and implementing signage projects at Massport airports.





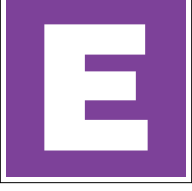

#### **4.1 SYMBOL LIBRARY**







The following symbols shall be used as indicated in this document. No modification - including color change - is permitted. Icons that imply direction are not to be modified to match the direction of travel.

The symbols and terminology included in the library are approved by Massport for use on wayfinding signs. Symbols not included are not permitted for use. Any new or customized symbols need to be approved by Massport before use.







Regulatory symbols, including shape, placement, and color on all vehicular regulatory signs shall conform to the Manual on Uniform Traffic Control Devices (MUTCD).







	Terminology	Applications	Usage
	Terminal A	<ul style="list-style-type: none"> <li>Identifies the Terminal that is designated as "A"</li> <li>To be used as an international symbol</li> </ul>	<ul style="list-style-type: none"> <li><input checked="" type="checkbox"/> Roadways</li> <li><input checked="" type="checkbox"/> Curbside</li> <li><input checked="" type="checkbox"/> Parking</li> <li><input checked="" type="checkbox"/> Terminals</li> <li><input type="checkbox"/> Service Buildings</li> </ul>
	Terminal B	<ul style="list-style-type: none"> <li>Identifies the Terminal that is designated as "B"</li> <li>To be used as an international symbol</li> </ul>	<ul style="list-style-type: none"> <li><input checked="" type="checkbox"/> Roadways</li> <li><input checked="" type="checkbox"/> Curbside</li> <li><input checked="" type="checkbox"/> Parking</li> <li><input checked="" type="checkbox"/> Terminals</li> <li><input type="checkbox"/> Service Buildings</li> </ul>
	Terminal C	<ul style="list-style-type: none"> <li>Identifies the Terminal that is designated as "C"</li> <li>To be used as an international symbol</li> </ul>	<ul style="list-style-type: none"> <li><input checked="" type="checkbox"/> Roadways</li> <li><input checked="" type="checkbox"/> Curbside</li> <li><input checked="" type="checkbox"/> Parking</li> <li><input checked="" type="checkbox"/> Terminals</li> <li><input type="checkbox"/> Service Buildings</li> </ul>
	Terminal E	<ul style="list-style-type: none"> <li>Identifies the Terminal that is designated as "E"</li> <li>To be used as an international symbol</li> </ul>	<ul style="list-style-type: none"> <li><input checked="" type="checkbox"/> Roadways</li> <li><input checked="" type="checkbox"/> Curbside</li> <li><input checked="" type="checkbox"/> Parking</li> <li><input checked="" type="checkbox"/> Terminals</li> <li><input type="checkbox"/> Service Buildings</li> </ul>
	Parking	<ul style="list-style-type: none"> <li>Identifies the Parking facilities</li> <li>To be used as an international symbol</li> </ul>	<ul style="list-style-type: none"> <li><input checked="" type="checkbox"/> Roadways</li> <li><input checked="" type="checkbox"/> Curbside</li> <li><input checked="" type="checkbox"/> Parking</li> <li><input checked="" type="checkbox"/> Terminals</li> <li><input type="checkbox"/> Service Buildings</li> </ul>
	Cell Phone Lot	<ul style="list-style-type: none"> <li>Identifies the Cell Phone Lot</li> </ul>	<ul style="list-style-type: none"> <li><input checked="" type="checkbox"/> Roadways</li> <li><input checked="" type="checkbox"/> Curbside</li> <li><input checked="" type="checkbox"/> Parking</li> <li><input type="checkbox"/> Terminals</li> <li><input type="checkbox"/> Service Buildings</li> </ul>





Terminology	Applications	Usage
	<p><b>Blue Line T</b></p> <ul style="list-style-type: none"> <li>Identifies Blue Line Transportation area</li> <li>Primary information on overhead directional signs at curbside</li> <li>Used on directional signs, ground transportation identification signs, and ground transportation directories</li> </ul>	<ul style="list-style-type: none"> <li><input type="checkbox"/> Roadways</li> <li><input checked="" type="checkbox"/> Curbside</li> <li><input type="checkbox"/> Parking</li> <li><input checked="" type="checkbox"/> Terminals</li> <li><input type="checkbox"/> Service Buildings</li> </ul>
	<p><b>Silver Line T</b></p> <ul style="list-style-type: none"> <li>Identifies Silver Line Transportation area</li> <li>Primary information on overhead directional signs at curbside</li> <li>Used on directional signs, ground transportation identification signs, and ground transportation directories</li> </ul>	<ul style="list-style-type: none"> <li><input type="checkbox"/> Roadways</li> <li><input checked="" type="checkbox"/> Curbside</li> <li><input type="checkbox"/> Parking</li> <li><input checked="" type="checkbox"/> Terminals</li> <li><input type="checkbox"/> Service Buildings</li> </ul>
	<p><b>Public Transportation</b></p> <ul style="list-style-type: none"> <li>Identifies Public Transportation area</li> <li>Primary information on overhead directional signs in the terminal.</li> <li>Used on directional signs and directories through the airport</li> </ul>	<ul style="list-style-type: none"> <li><input type="checkbox"/> Roadways</li> <li><input type="checkbox"/> Curbside</li> <li><input type="checkbox"/> Parking</li> <li><input checked="" type="checkbox"/> Terminals</li> <li><input type="checkbox"/> Service Buildings</li> </ul>
	<p><b>Ground Transportation</b></p> <ul style="list-style-type: none"> <li>Identifies Ground Transportation area</li> <li>Primary information on overhead directional signs in the terminal and curbside</li> <li>Used on directional signs and directories through the airport</li> </ul>	<ul style="list-style-type: none"> <li><input type="checkbox"/> Roadways</li> <li><input type="checkbox"/> Curbside</li> <li><input type="checkbox"/> Parking</li> <li><input checked="" type="checkbox"/> Terminals</li> <li><input type="checkbox"/> Service Buildings</li> </ul>
	<p><b>Logan Express</b> <b>Scheduled Bus</b></p> <ul style="list-style-type: none"> <li>Identifies Logan Express and Scheduled Bus area</li> <li>Primary information on overhead directional signs at curbside</li> <li>Used on directional signs, ground transportation identification signs, and ground transportation directories</li> </ul>	<ul style="list-style-type: none"> <li><input type="checkbox"/> Roadways</li> <li><input checked="" type="checkbox"/> Curbside</li> <li><input type="checkbox"/> Parking</li> <li><input checked="" type="checkbox"/> Terminals</li> <li><input type="checkbox"/> Service Buildings</li> </ul>
	<p><b>Charter Bus</b></p> <ul style="list-style-type: none"> <li>Identifies Charter Bus area</li> <li>Primary information on overhead directional signs at curbside</li> <li>Used on directional signs, ground transportation identification signs, and ground transportation directories</li> </ul>	<ul style="list-style-type: none"> <li><input type="checkbox"/> Roadways</li> <li><input checked="" type="checkbox"/> Curbside</li> <li><input type="checkbox"/> Parking</li> <li><input checked="" type="checkbox"/> Terminals</li> <li><input type="checkbox"/> Service Buildings</li> </ul>



Terminology	Applications	Usage	
	<p><b>Taxi</b></p>	<ul style="list-style-type: none"> <li>• Identifies Taxi Transportation area</li> <li>• Primary information on overhead directional signs at curbside</li> <li>• Used on directional signs, ground transportation identification signs, and ground transportation directories</li> </ul>	<ul style="list-style-type: none"> <li><input type="checkbox"/> Roadways</li> <li><input checked="" type="checkbox"/> Curbside</li> <li><input type="checkbox"/> Parking</li> <li><input checked="" type="checkbox"/> Terminals</li> <li><input type="checkbox"/> Service Buildings</li> </ul>
	<p><b>Passenger Pickup</b></p>	<ul style="list-style-type: none"> <li>• Identifies Passenger Pickup area</li> <li>• Primary information on overhead directional signs at curbside</li> <li>• Used on directional signs, ground transportation identification signs, and ground transportation directories</li> </ul>	<ul style="list-style-type: none"> <li><input type="checkbox"/> Roadways</li> <li><input checked="" type="checkbox"/> Curbside</li> <li><input type="checkbox"/> Parking</li> <li><input checked="" type="checkbox"/> Terminals</li> <li><input type="checkbox"/> Service Buildings</li> </ul>
	<p><b>Silver Line</b></p>	<ul style="list-style-type: none"> <li>• Identifies Silver Line area</li> <li>• Primary information on overhead directional signs at curbside</li> <li>• Used on directional signs, ground transportation identification signs, and ground transportation directories</li> </ul>	<ul style="list-style-type: none"> <li><input type="checkbox"/> Roadways</li> <li><input checked="" type="checkbox"/> Curbside</li> <li><input type="checkbox"/> Parking</li> <li><input checked="" type="checkbox"/> Terminals</li> <li><input type="checkbox"/> Service Buildings</li> </ul>
	<p><b>Limos</b></p>	<ul style="list-style-type: none"> <li>• Identifies Limos area</li> <li>• Primary information on overhead directional signs at curbside</li> <li>• Used on directional signs, ground transportation identification signs, and ground transportation directories</li> </ul>	<ul style="list-style-type: none"> <li><input type="checkbox"/> Roadways</li> <li><input checked="" type="checkbox"/> Curbside</li> <li><input type="checkbox"/> Parking</li> <li><input checked="" type="checkbox"/> Terminals</li> <li><input type="checkbox"/> Service Buildings</li> </ul>
	<p><b>Airport Shuttle Rental Car - Blue Line</b></p>	<ul style="list-style-type: none"> <li>• Identifies Airport Shuttle and Rental Car - Blue Line area</li> <li>• Primary information on overhead directional signs at curbside</li> <li>• Used on directional signs, ground transportation identification signs, and ground transportation directories</li> </ul>	<ul style="list-style-type: none"> <li><input type="checkbox"/> Roadways</li> <li><input checked="" type="checkbox"/> Curbside</li> <li><input type="checkbox"/> Parking</li> <li><input checked="" type="checkbox"/> Terminals</li> <li><input type="checkbox"/> Service Buildings</li> </ul>
	<p><b>Courtesy Bus Shared Van</b></p>	<ul style="list-style-type: none"> <li>• Identifies Courtesy Bus or Shared Van areas</li> <li>• Primary information on overhead directional signs at curbside</li> <li>• Used on directional signs, ground transportation identification signs, and ground transportation directories</li> </ul>	<ul style="list-style-type: none"> <li><input type="checkbox"/> Roadways</li> <li><input checked="" type="checkbox"/> Curbside</li> <li><input type="checkbox"/> Parking</li> <li><input checked="" type="checkbox"/> Terminals</li> <li><input type="checkbox"/> Service Buildings</li> </ul>



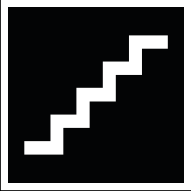



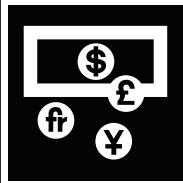
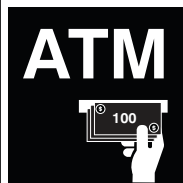
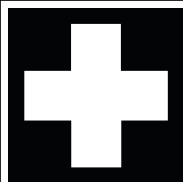

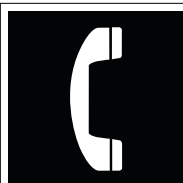

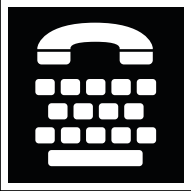

	Terminology	Applications	Usage
	<b>Baggage Claim</b>	<ul style="list-style-type: none"> <li>Identifies Baggage Claim</li> <li>Primary information on overhead directional signs in the terminals</li> </ul>	<ul style="list-style-type: none"> <li><input type="checkbox"/> Roadways</li> <li><input checked="" type="checkbox"/> Curbside</li> <li><input type="checkbox"/> Parking</li> <li><input checked="" type="checkbox"/> Terminals</li> <li><input type="checkbox"/> Service Buildings</li> </ul>
	<b>Gate</b>	<ul style="list-style-type: none"> <li>Identifies a Gate</li> <li>Primary information on overhead directional signs in the terminals</li> </ul>	<ul style="list-style-type: none"> <li><input type="checkbox"/> Roadways</li> <li><input type="checkbox"/> Curbside</li> <li><input type="checkbox"/> Parking</li> <li><input checked="" type="checkbox"/> Terminals</li> <li><input type="checkbox"/> Service Buildings</li> </ul>
	<b>Ticketing</b>	<ul style="list-style-type: none"> <li>Identifies Ticketing and Baggage Check-in areas</li> <li>Primary information on overhead directional signs in the terminals</li> </ul>	<ul style="list-style-type: none"> <li><input type="checkbox"/> Roadways</li> <li><input checked="" type="checkbox"/> Curbside</li> <li><input type="checkbox"/> Parking</li> <li><input checked="" type="checkbox"/> Terminals</li> <li><input type="checkbox"/> Service Buildings</li> </ul>
	<b>Connecting Flights</b>	<ul style="list-style-type: none"> <li>Identifies Connecting Flights</li> <li>Primary information on overhead directional signs</li> </ul>	<ul style="list-style-type: none"> <li><input type="checkbox"/> Roadways</li> <li><input type="checkbox"/> Curbside</li> <li><input type="checkbox"/> Parking</li> <li><input checked="" type="checkbox"/> Terminals</li> <li><input type="checkbox"/> Service Buildings</li> </ul>
	<b>Arrivals</b>	<ul style="list-style-type: none"> <li>Identifies Arrivals level at roadway</li> <li>Identifies the Arrivals/Meeters and Greeters Lobby curbside</li> <li>Symbol and term combination is used on directional signs only</li> </ul>	<ul style="list-style-type: none"> <li><input checked="" type="checkbox"/> Roadways</li> <li><input type="checkbox"/> Curbside</li> <li><input type="checkbox"/> Parking</li> <li><input checked="" type="checkbox"/> Terminals</li> <li><input type="checkbox"/> Service Buildings</li> </ul>
	<b>Departures</b>	<ul style="list-style-type: none"> <li>Identifies Departures level at roadway</li> <li>Symbol and term combination is used on directional signs only</li> </ul>	<ul style="list-style-type: none"> <li><input checked="" type="checkbox"/> Roadways</li> <li><input type="checkbox"/> Curbside</li> <li><input type="checkbox"/> Parking</li> <li><input checked="" type="checkbox"/> Terminals</li> <li><input type="checkbox"/> Service Buildings</li> </ul>

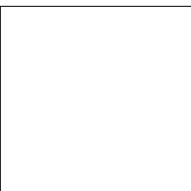





	Terminology	Applications	Usage
	<p><b>Security Badge</b></p>	<ul style="list-style-type: none"> <li>Identifies Security Badge Office</li> <li>Secondary information on overhead directional signs in the terminal</li> <li>Used on directional signs and directories through the airport</li> </ul>	<ul style="list-style-type: none"> <li><input type="checkbox"/> Roadways</li> <li><input type="checkbox"/> Curbside</li> <li><input type="checkbox"/> Parking</li> <li><input checked="" type="checkbox"/> Terminals</li> <li><input type="checkbox"/> Service Buildings</li> </ul>
	<p><b>Airport Shuttle</b> <b>Charter Bus</b> <b>Hotel Shuttle</b> <b>Logan Express</b> <b>Rental Car Shuttle</b> <b>Scheduled Bus</b></p>	<ul style="list-style-type: none"> <li>Identifies Ground Transportation area</li> <li>Primary information on overhead directional signs at curbside</li> <li>Used on directional signs, ground transportation identification signs, and ground transportation directories</li> </ul>	<ul style="list-style-type: none"> <li><input type="checkbox"/> Roadways</li> <li><input checked="" type="checkbox"/> Curbside</li> <li><input checked="" type="checkbox"/> Parking</li> <li><input checked="" type="checkbox"/> Terminals</li> <li><input type="checkbox"/> Service Buildings</li> </ul>
	<p><b>Silver Line</b></p>	<ul style="list-style-type: none"> <li>Identifies Silver line Transportation area</li> <li>Primary information on overhead directional signs at curbside</li> <li>Used on directional signs, ground transportation identification signs, and ground transportation directories</li> </ul>	<ul style="list-style-type: none"> <li><input type="checkbox"/> Roadways</li> <li><input checked="" type="checkbox"/> Curbside</li> <li><input type="checkbox"/> Parking</li> <li><input checked="" type="checkbox"/> Terminals</li> <li><input type="checkbox"/> Service Buildings</li> </ul>
	<p><b>Limos</b></p>	<ul style="list-style-type: none"> <li>Identifies Ground Transportation area</li> <li>Primary information on overhead directional signs at curbside</li> <li>Used on directional signs, ground transportation identification signs, and ground transportation directories</li> </ul>	<ul style="list-style-type: none"> <li><input type="checkbox"/> Roadways</li> <li><input checked="" type="checkbox"/> Curbside</li> <li><input type="checkbox"/> Parking</li> <li><input checked="" type="checkbox"/> Terminals</li> <li><input type="checkbox"/> Service Buildings</li> </ul>
	<p><b>Rental Car</b></p>	<ul style="list-style-type: none"> <li>Identifies Rental Car area</li> <li>Primary information on overhead directional signs at ConRAC</li> <li>Used on directional signs and identification signs</li> </ul>	<ul style="list-style-type: none"> <li><input type="checkbox"/> Roadways</li> <li><input checked="" type="checkbox"/> Curbside</li> <li><input type="checkbox"/> Parking</li> <li><input checked="" type="checkbox"/> Terminals</li> <li><input type="checkbox"/> Service Buildings</li> </ul>
	<p><b>Shared Van</b> <b>Courtesy Bus</b></p>	<ul style="list-style-type: none"> <li>Identifies Ground Transportation area</li> <li>Primary information on overhead directional signs at curbside</li> <li>Used on directional signs, ground transportation identification signs, and ground transportation directories</li> </ul>	<ul style="list-style-type: none"> <li><input type="checkbox"/> Roadways</li> <li><input checked="" type="checkbox"/> Curbside</li> <li><input type="checkbox"/> Parking</li> <li><input checked="" type="checkbox"/> Terminals</li> <li><input type="checkbox"/> Service Buildings</li> </ul>

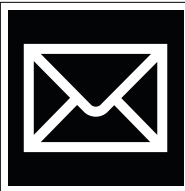

Terminology	Applications	Usage	
	<p><b>Taxi</b></p>	<ul style="list-style-type: none"> <li>• Identifies Ground Transportation area</li> <li>• Primary information on overhead directional signs at curbside</li> <li>• Used on directional signs, ground transportation identification signs, and ground transportation directories</li> </ul>	<ul style="list-style-type: none"> <li><input type="checkbox"/> Roadways</li> <li><input checked="" type="checkbox"/> Curbside</li> <li><input type="checkbox"/> Parking</li> <li><input checked="" type="checkbox"/> Terminals</li> <li><input type="checkbox"/> Service Buildings</li> </ul>
	<p><b>Elevator</b></p>	<ul style="list-style-type: none"> <li>• Identifies an elevator</li> </ul>	<ul style="list-style-type: none"> <li><input type="checkbox"/> Roadways</li> <li><input checked="" type="checkbox"/> Curbside</li> <li><input checked="" type="checkbox"/> Parking</li> <li><input checked="" type="checkbox"/> Terminals</li> <li><input checked="" type="checkbox"/> Service Buildings</li> </ul>
	<p><b>Escalator</b></p>	<ul style="list-style-type: none"> <li>• Identifies an escalator</li> </ul>	<ul style="list-style-type: none"> <li><input type="checkbox"/> Roadways</li> <li><input type="checkbox"/> Curbside</li> <li><input type="checkbox"/> Parking</li> <li><input checked="" type="checkbox"/> Terminals</li> <li><input type="checkbox"/> Service Buildings</li> </ul>
	<p><b>Stairs</b></p>	<ul style="list-style-type: none"> <li>• Identifies an enclosed stairwell</li> </ul>	<ul style="list-style-type: none"> <li><input type="checkbox"/> Roadways</li> <li><input type="checkbox"/> Curbside</li> <li><input checked="" type="checkbox"/> Parking</li> <li><input checked="" type="checkbox"/> Terminals</li> <li><input checked="" type="checkbox"/> Service Buildings</li> </ul>
	<p><b>Emergency Stairs</b></p>	<ul style="list-style-type: none"> <li>• Identifies an emergency stairwell</li> </ul>	<ul style="list-style-type: none"> <li><input type="checkbox"/> Roadways</li> <li><input type="checkbox"/> Curbside</li> <li><input checked="" type="checkbox"/> Parking</li> <li><input checked="" type="checkbox"/> Terminals</li> <li><input checked="" type="checkbox"/> Service Buildings</li> </ul>
	<p><b>Baggage Services</b></p>	<ul style="list-style-type: none"> <li>• Identifies the various airline baggage service offices</li> <li>• Not used on overhead directional signs</li> </ul>	<ul style="list-style-type: none"> <li><input type="checkbox"/> Roadways</li> <li><input checked="" type="checkbox"/> Curbside</li> <li><input type="checkbox"/> Parking</li> <li><input checked="" type="checkbox"/> Terminals</li> <li><input type="checkbox"/> Service Buildings</li> </ul>

	Terminology	Applications	Usage
	<b>Baggage Carts</b>	<ul style="list-style-type: none"> <li>Identifies the baggage cart dispenser</li> <li>Not used on overhead directional signs</li> </ul>	<ul style="list-style-type: none"> <li><input type="checkbox"/> Roadways</li> <li><input checked="" type="checkbox"/> Curbside</li> <li><input type="checkbox"/> Parking</li> <li><input checked="" type="checkbox"/> Terminals</li> <li><input type="checkbox"/> Service Buildings</li> </ul>
	<b>Currency Exchange</b>	<ul style="list-style-type: none"> <li>Identifies a currency exchange station</li> <li>Not used on overhead directional signs</li> </ul>	<ul style="list-style-type: none"> <li><input type="checkbox"/> Roadways</li> <li><input type="checkbox"/> Curbside</li> <li><input type="checkbox"/> Parking</li> <li><input checked="" type="checkbox"/> Terminals</li> <li><input type="checkbox"/> Service Buildings</li> </ul>
	<b>ATM/Money</b>	<ul style="list-style-type: none"> <li>Identifies an automatic teller machine</li> <li>Used on directories throughout the airport</li> <li>Not used on overhead directional signs</li> </ul>	<ul style="list-style-type: none"> <li><input type="checkbox"/> Roadways</li> <li><input type="checkbox"/> Curbside</li> <li><input type="checkbox"/> Parking</li> <li><input checked="" type="checkbox"/> Terminals</li> <li><input type="checkbox"/> Service Buildings</li> </ul>
	<b>First Aid</b>	<ul style="list-style-type: none"> <li>Identifies a first aid station</li> <li>Not used on overhead directional signs</li> </ul>	<ul style="list-style-type: none"> <li><input type="checkbox"/> Roadways</li> <li><input type="checkbox"/> Curbside</li> <li><input type="checkbox"/> Parking</li> <li><input checked="" type="checkbox"/> Terminals</li> <li><input type="checkbox"/> Service Buildings</li> </ul>
	<b>Fire Extinguisher</b>	<ul style="list-style-type: none"> <li>Identifies the fire extinguisher locations</li> <li>Not used on overhead directional signs</li> </ul>	<ul style="list-style-type: none"> <li><input type="checkbox"/> Roadways</li> <li><input type="checkbox"/> Curbside</li> <li><input checked="" type="checkbox"/> Parking</li> <li><input checked="" type="checkbox"/> Terminals</li> <li><input checked="" type="checkbox"/> Service Buildings</li> </ul>
	<b>Telephone</b>	<ul style="list-style-type: none"> <li>Identifies Telephone locations</li> <li>Used on directories throughout the airport</li> <li>Not used on overhead directional signs</li> </ul>	<ul style="list-style-type: none"> <li><input type="checkbox"/> Roadways</li> <li><input type="checkbox"/> Curbside</li> <li><input type="checkbox"/> Parking</li> <li><input checked="" type="checkbox"/> Terminals</li> <li><input type="checkbox"/> Service Buildings</li> </ul>







Terminology	Applications	Usage
	<p><b>TDD/TTY</b></p> <ul style="list-style-type: none"> <li>Identifies location(s) for telecommunications devices</li> <li>Not used on overhead directional signs</li> </ul>	<ul style="list-style-type: none"> <li><input type="checkbox"/> Roadways</li> <li><input type="checkbox"/> Curbside</li> <li><input type="checkbox"/> Parking</li> <li><input checked="" type="checkbox"/> Terminals</li> <li><input type="checkbox"/> Service Buildings</li> </ul>
	<p><b>Assisted Listening</b></p> <ul style="list-style-type: none"> <li>Identifies Assisted Listening services</li> <li>Not used on overhead directional signs</li> </ul>	<ul style="list-style-type: none"> <li><input type="checkbox"/> Roadways</li> <li><input type="checkbox"/> Curbside</li> <li><input type="checkbox"/> Parking</li> <li><input checked="" type="checkbox"/> Terminals</li> <li><input type="checkbox"/> Service Buildings</li> </ul>
	<p><b>Handicap Access</b></p> <ul style="list-style-type: none"> <li>Identifies wheelchair accessible locations</li> <li>Used on directories throughout the airport</li> <li>Not used on overhead directional signs</li> </ul>	<ul style="list-style-type: none"> <li><input type="checkbox"/> Roadways</li> <li><input checked="" type="checkbox"/> Curbside</li> <li><input checked="" type="checkbox"/> Parking</li> <li><input checked="" type="checkbox"/> Terminals</li> <li><input checked="" type="checkbox"/> Service Buildings</li> </ul>
	<p><b>Information</b></p> <ul style="list-style-type: none"> <li>Identifies information locations</li> <li>Used on directories throughout the airport</li> <li>Not used on overhead directional signs</li> </ul>	<ul style="list-style-type: none"> <li><input type="checkbox"/> Roadways</li> <li><input checked="" type="checkbox"/> Curbside</li> <li><input type="checkbox"/> Parking</li> <li><input checked="" type="checkbox"/> Terminals</li> <li><input checked="" type="checkbox"/> Service Buildings</li> </ul>
	<p><b>Infobar</b></p> <ul style="list-style-type: none"> <li>Identifies information kiosks at infobar locations</li> </ul>	<ul style="list-style-type: none"> <li><input type="checkbox"/> Roadways</li> <li><input type="checkbox"/> Curbside</li> <li><input type="checkbox"/> Parking</li> <li><input checked="" type="checkbox"/> Terminals</li> <li><input type="checkbox"/> Service Buildings</li> </ul>
	<p><b>Interactive Directory</b></p> <ul style="list-style-type: none"> <li>Identifies Interactive Directory</li> </ul>	<ul style="list-style-type: none"> <li><input type="checkbox"/> Roadways</li> <li><input type="checkbox"/> Curbside</li> <li><input type="checkbox"/> Parking</li> <li><input checked="" type="checkbox"/> Terminals</li> <li><input type="checkbox"/> Service Buildings</li> </ul>





	Terminology	Applications	Usage
	<b>Restrooms</b>	<ul style="list-style-type: none"> <li>Identifies a restroom</li> <li>Appears on identification signage throughout the airport</li> <li>Appears on directories throughout the airport</li> </ul>	<ul style="list-style-type: none"> <li><input type="checkbox"/> Roadways</li> <li><input type="checkbox"/> Curbside</li> <li><input type="checkbox"/> Parking</li> <li><input checked="" type="checkbox"/> Terminals</li> <li><input checked="" type="checkbox"/> Service Buildings</li> </ul>
	<b>Men's Restroom</b>	<ul style="list-style-type: none"> <li>Identifies a Men's restroom</li> <li>Not used on overhead directional signs</li> </ul>	<ul style="list-style-type: none"> <li><input type="checkbox"/> Roadways</li> <li><input type="checkbox"/> Curbside</li> <li><input type="checkbox"/> Parking</li> <li><input checked="" type="checkbox"/> Terminals</li> <li><input checked="" type="checkbox"/> Service Buildings</li> </ul>
	<b>Women's Restroom</b>	<ul style="list-style-type: none"> <li>Identifies a Women's restroom</li> <li>Not used on overhead directional signs</li> </ul>	<ul style="list-style-type: none"> <li><input type="checkbox"/> Roadways</li> <li><input type="checkbox"/> Curbside</li> <li><input type="checkbox"/> Parking</li> <li><input checked="" type="checkbox"/> Terminals</li> <li><input checked="" type="checkbox"/> Service Buildings</li> </ul>
	<b>Assisted Care Men</b>	<ul style="list-style-type: none"> <li>Identifies an accessible Men's restroom</li> <li>Not used on overhead directional signs</li> </ul>	<ul style="list-style-type: none"> <li><input type="checkbox"/> Roadways</li> <li><input type="checkbox"/> Curbside</li> <li><input type="checkbox"/> Parking</li> <li><input checked="" type="checkbox"/> Terminals</li> <li><input checked="" type="checkbox"/> Service Buildings</li> </ul>
	<b>Assisted Care Women</b>	<ul style="list-style-type: none"> <li>Identifies an accessible Women's restroom</li> <li>Not used on overhead directional signs</li> </ul>	<ul style="list-style-type: none"> <li><input type="checkbox"/> Roadways</li> <li><input type="checkbox"/> Curbside</li> <li><input type="checkbox"/> Parking</li> <li><input checked="" type="checkbox"/> Terminals</li> <li><input checked="" type="checkbox"/> Service Buildings</li> </ul>
	<b>Assisted Care Family</b>	<ul style="list-style-type: none"> <li>Identifies an assisted care and family restroom</li> <li>Not used on overhead directional signs</li> </ul>	<ul style="list-style-type: none"> <li><input type="checkbox"/> Roadways</li> <li><input type="checkbox"/> Curbside</li> <li><input type="checkbox"/> Parking</li> <li><input checked="" type="checkbox"/> Terminals</li> <li><input checked="" type="checkbox"/> Service Buildings</li> </ul>



	Terminology	Applications	Usage
	<b>Diaper Changing Station</b>	<ul style="list-style-type: none"> <li>Identifies a diaper changing station or nursery</li> <li>Not used on overhead directional signs</li> </ul>	<ul style="list-style-type: none"> <li><input type="checkbox"/> Roadways</li> <li><input type="checkbox"/> Curbside</li> <li><input type="checkbox"/> Parking</li> <li><input checked="" type="checkbox"/> Terminals</li> <li><input checked="" type="checkbox"/> Service Buildings</li> </ul>
	<b>Water Fountain</b>	<ul style="list-style-type: none"> <li>Identifies a water fountain</li> <li>Not used on overhead directional signs</li> </ul>	<ul style="list-style-type: none"> <li><input type="checkbox"/> Roadways</li> <li><input type="checkbox"/> Curbside</li> <li><input type="checkbox"/> Parking</li> <li><input checked="" type="checkbox"/> Terminals</li> <li><input checked="" type="checkbox"/> Service Buildings</li> </ul>
	<b>Postal Service</b>	<ul style="list-style-type: none"> <li>Identifies a U.S. Mail Box</li> <li>Appears on directories throughout the airport</li> <li>Not used on overhead directional signs</li> </ul>	<ul style="list-style-type: none"> <li><input type="checkbox"/> Roadways</li> <li><input type="checkbox"/> Curbside</li> <li><input type="checkbox"/> Parking</li> <li><input checked="" type="checkbox"/> Terminals</li> <li><input checked="" type="checkbox"/> Service Buildings</li> </ul>
	<b>Lost and Found</b>	<ul style="list-style-type: none"> <li>Identifies the lost and found office</li> <li>Appears on directories throughout the airport</li> <li>Not used on overhead directional signs</li> </ul>	<ul style="list-style-type: none"> <li><input type="checkbox"/> Roadways</li> <li><input type="checkbox"/> Curbside</li> <li><input type="checkbox"/> Parking</li> <li><input checked="" type="checkbox"/> Terminals</li> <li><input type="checkbox"/> Service Buildings</li> </ul>
	<b>Hotel Information</b>	<ul style="list-style-type: none"> <li>Identifies the location of hotel information</li> <li>Appears on directories throughout the airport</li> <li>Not used on overhead directional signs</li> </ul>	<ul style="list-style-type: none"> <li><input type="checkbox"/> Roadways</li> <li><input type="checkbox"/> Curbside</li> <li><input type="checkbox"/> Parking</li> <li><input checked="" type="checkbox"/> Terminals</li> <li><input type="checkbox"/> Service Buildings</li> </ul>
	<b>In-Transit Lounge</b>	<ul style="list-style-type: none"> <li>Identifies the location of the In-Transit Lounge</li> <li>Appears on directories throughout the airport</li> <li>Not used on overhead directional signs</li> </ul>	<ul style="list-style-type: none"> <li><input type="checkbox"/> Roadways</li> <li><input type="checkbox"/> Curbside</li> <li><input type="checkbox"/> Parking</li> <li><input checked="" type="checkbox"/> Terminals</li> <li><input type="checkbox"/> Service Buildings</li> </ul>

Terminology	Applications	Usage
	<p><b>No Smoking</b></p> <ul style="list-style-type: none"> <li>Identifies areas where smoking is prohibited</li> <li>Not used on overhead directional signs</li> </ul>	<ul style="list-style-type: none"> <li><input type="checkbox"/> Roadways</li> <li><input checked="" type="checkbox"/> Curbside</li> <li><input type="checkbox"/> Parking</li> <li><input checked="" type="checkbox"/> Terminals</li> <li><input checked="" type="checkbox"/> Service Buildings</li> </ul>
	<p><b>Designated Smoking Area</b></p> <ul style="list-style-type: none"> <li>Identifies areas where smoking is permitted</li> <li>Appears on directories throughout the airport</li> <li>Not used on overhead directional signs</li> </ul>	<ul style="list-style-type: none"> <li><input type="checkbox"/> Roadways</li> <li><input checked="" type="checkbox"/> Curbside</li> <li><input type="checkbox"/> Parking</li> <li><input checked="" type="checkbox"/> Terminals</li> <li><input type="checkbox"/> Service Buildings</li> </ul>
	<p><b>No Weapons</b></p> <ul style="list-style-type: none"> <li>Used on all FAA restrictive signage regarding the Transportation of Hazardous Materials</li> <li>Used at security checkpoints</li> <li>Not used on overhead directional signs</li> </ul>	<ul style="list-style-type: none"> <li><input type="checkbox"/> Roadways</li> <li><input checked="" type="checkbox"/> Curbside</li> <li><input type="checkbox"/> Parking</li> <li><input checked="" type="checkbox"/> Terminals</li> <li><input type="checkbox"/> Service Buildings</li> </ul>
	<p><b>No Uncaged Animals</b></p> <ul style="list-style-type: none"> <li>Used at public entries of terminals</li> <li>Not used on overhead directional signs</li> </ul>	<ul style="list-style-type: none"> <li><input type="checkbox"/> Roadways</li> <li><input checked="" type="checkbox"/> Curbside</li> <li><input type="checkbox"/> Parking</li> <li><input checked="" type="checkbox"/> Terminals</li> <li><input type="checkbox"/> Service Buildings</li> </ul>
	<p><b>DO NOT ENTER</b></p> <ul style="list-style-type: none"> <li>Identifies a restricted area</li> <li>Not used on overhead directional signs</li> </ul>	<ul style="list-style-type: none"> <li><input type="checkbox"/> Roadways</li> <li><input type="checkbox"/> Curbside</li> <li><input checked="" type="checkbox"/> Parking</li> <li><input checked="" type="checkbox"/> Terminals</li> <li><input checked="" type="checkbox"/> Service Buildings</li> </ul>
	<p><b>EXIT</b></p> <ul style="list-style-type: none"> <li>Identifies a common exit to the facility</li> <li>Not used on overhead directional signs</li> </ul>	<ul style="list-style-type: none"> <li><input type="checkbox"/> Roadways</li> <li><input type="checkbox"/> Curbside</li> <li><input type="checkbox"/> Parking</li> <li><input checked="" type="checkbox"/> Terminals</li> <li><input checked="" type="checkbox"/> Service Buildings</li> </ul>



	Terminology	Applications	Usage
	<b>Passport Control</b>	<ul style="list-style-type: none"> <li>• Identifies the immigration area</li> <li>• Used in the FIS area only</li> </ul>	<ul style="list-style-type: none"> <li><input type="checkbox"/> Roadways</li> <li><input type="checkbox"/> Curbside</li> <li><input type="checkbox"/> Parking</li> <li><input checked="" type="checkbox"/> Terminals</li> <li><input type="checkbox"/> Service Buildings</li> </ul>
	<b>No Parking</b>	<ul style="list-style-type: none"> <li>• Identifies areas where parking is not permitted</li> </ul>	<ul style="list-style-type: none"> <li><input checked="" type="checkbox"/> Roadways</li> <li><input checked="" type="checkbox"/> Curbside</li> <li><input checked="" type="checkbox"/> Parking</li> <li><input type="checkbox"/> Terminals</li> <li><input type="checkbox"/> Service Buildings</li> </ul>
	<b>Pedestrians</b>	<ul style="list-style-type: none"> <li>• Identifies areas where pedestrians are permitted</li> <li>• Used on regulatory signs</li> </ul>	<ul style="list-style-type: none"> <li><input type="checkbox"/> Roadways</li> <li><input checked="" type="checkbox"/> Curbside</li> <li><input checked="" type="checkbox"/> Parking</li> <li><input type="checkbox"/> Terminals</li> <li><input type="checkbox"/> Service Buildings</li> </ul>
	<b>Pedestrian Prohibited</b>	<ul style="list-style-type: none"> <li>• Identifies areas where pedestrians are not allowed</li> <li>• Used on regulatory signs</li> </ul>	<ul style="list-style-type: none"> <li><input type="checkbox"/> Roadways</li> <li><input checked="" type="checkbox"/> Curbside</li> <li><input checked="" type="checkbox"/> Parking</li> <li><input type="checkbox"/> Terminals</li> <li><input type="checkbox"/> Service Buildings</li> </ul>
	<b>Pedestrian Prohibited</b>	<ul style="list-style-type: none"> <li>• Identifies areas where pedestrians are not allowed</li> </ul>	<ul style="list-style-type: none"> <li><input checked="" type="checkbox"/> Roadways</li> <li><input checked="" type="checkbox"/> Curbside</li> <li><input checked="" type="checkbox"/> Parking</li> <li><input type="checkbox"/> Terminals</li> <li><input type="checkbox"/> Service Buildings</li> </ul>
	<b>Pedestrian Crosswalk</b>	<ul style="list-style-type: none"> <li>• Identifies a pedestrian path of travel to a crosswalk</li> <li>• Used on directional signs</li> <li>• Symbol to be oriented to match direction of travel</li> </ul>	<ul style="list-style-type: none"> <li><input type="checkbox"/> Roadways</li> <li><input type="checkbox"/> Curbside</li> <li><input checked="" type="checkbox"/> Parking</li> <li><input type="checkbox"/> Terminals</li> <li><input type="checkbox"/> Service Buildings</li> </ul>

Terminology	Applications	Usage
	<b>Parking Violations</b> <ul style="list-style-type: none"> <li>• Identifies Parking Violations Office</li> <li>• Secondary information on overhead directional signs</li> <li>• Used on directional signs</li> </ul>	<input type="checkbox"/> Roadways <input type="checkbox"/> Curbside <input type="checkbox"/> Parking <input checked="" type="checkbox"/> Terminals <input type="checkbox"/> Service Buildings
	<b>Food &amp; Beverage</b> <ul style="list-style-type: none"> <li>• Identifies food services and restaurants</li> <li>• Symbol appears on directories</li> </ul>	<input type="checkbox"/> Roadways <input type="checkbox"/> Curbside <input type="checkbox"/> Parking <input checked="" type="checkbox"/> Terminals <input type="checkbox"/> Service Buildings
	<b>Retail</b> <ul style="list-style-type: none"> <li>• Identifies retail services</li> <li>• Symbol appears on directories</li> </ul>	<input type="checkbox"/> Roadways <input type="checkbox"/> Curbside <input type="checkbox"/> Parking <input checked="" type="checkbox"/> Terminals <input type="checkbox"/> Service Buildings
	<b>Pet Port</b> <ul style="list-style-type: none"> <li>• Identifies Pet Port</li> <li>• Not used on overhead directional signs</li> </ul>	<input type="checkbox"/> Roadways <input checked="" type="checkbox"/> Curbside <input type="checkbox"/> Parking <input checked="" type="checkbox"/> Terminals <input type="checkbox"/> Service Buildings
	<b>No Cell Phones</b> <ul style="list-style-type: none"> <li>• Identifies areas where cell phone usage is prohibited</li> </ul>	<input type="checkbox"/> Roadways <input type="checkbox"/> Curbside <input type="checkbox"/> Parking <input checked="" type="checkbox"/> Terminals <input type="checkbox"/> Service Buildings

Terminology	Applications	Usage
	<p><b>Meeting Point</b></p> <ul style="list-style-type: none"> <li>Identifies areas designated as Meeting Points</li> </ul>	<ul style="list-style-type: none"> <li><input type="checkbox"/> Roadways</li> <li><input type="checkbox"/> Curbside</li> <li><input type="checkbox"/> Parking</li> <li><input checked="" type="checkbox"/> Terminals</li> <li><input type="checkbox"/> Service Buildings</li> </ul>
	<p><b>USO</b></p> <ul style="list-style-type: none"> <li>Identifies United Services Organizations Office</li> <li>Secondary information on overhead directional signs</li> <li>Used on directional signs,</li> </ul>	<ul style="list-style-type: none"> <li><input type="checkbox"/> Roadways</li> <li><input type="checkbox"/> Curbside</li> <li><input type="checkbox"/> Parking</li> <li><input checked="" type="checkbox"/> Terminals</li> <li><input type="checkbox"/> Service Buildings</li> </ul>

## 4.2 ARROW LIBRARY

The following arrows shall be used as indicated in this document. No modification, including color change, is permitted.

Pedestrian Arrows

---



Up to the Left

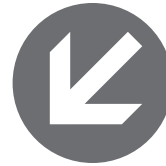

Down to the Left



Up or Straight Ahead



Down



Up to the Right



Down to the Right



To the Left



Behind ( U-Turn)

*Note: Use is Discouraged*



To the Right

Vehicular Arrows

---



To the Left



To the Right



Straight Ahead on the Left



Straight Ahead



Straight Ahead on the Right

### 4.3 MASSPORT ARTWORK LIBRARY

The following graphic artwork is provided as sample. Designers shall procure the latest versions from Massport. No modification to the artwork is permitted.

Boston Logan International Airport



Airport Directory Map

<h3>Information</h3> <p><b>Ground Transportation Services</b>              Ground Transportation connections are available at all Terminals.              Ask curbside dispatchers or phone:              1-800-23-LOGAN, TTY 1-800-262-3325</p> <p><b>Information Booths</b>              Ground Transportation and Foreign Language Assistance is available at the Massport Information Booths located in the Lower Level Baggage Claim area of all Terminals.</p> <p><b>Massachusetts State Police</b>              Troop F, 617-568-7300</p> <p><b>Massport Fire Rescue/Medical Emergency</b>              617-567-2020</p>	<h3>Airlines</h3> <p><b>A</b> Delta  <small>Except International Arrivals</small>              Delta Shuttle</p> <p><b>B</b> Air Canada              American              PenAir              Spirit              United</p> <p><b>C</b> Alaska              Cape Air              Emirates  <small>Dependence Only</small></p> <p>Southwest</p> <p>United Express              US Airways              US Airways Express              US Airways Shuttle              Virgin America</p> <p>JetBlue  <small>Except International Arrivals</small>              Sun Country</p>	<p><b>E All International Arrivals</b>  <small>International Departures vary with Airline.</small></p> <p>Aer Lingus              Air France              Alitalia              American  <small>International Arrivals Only</small>              British Airways              Cathay Pacific              CopaAirlines              Delta              Emirates  <small>International Arrivals Only</small>              Hainan Airlines              Iberia              Icelandair</p> <p>Japan Airlines              JetBlue  <small>International Arrivals Only</small>              Lufthansa              Porter              SATA              SWISS              TACV              Turkish Airlines              Virgin Atlantic              WOW</p>
---	---	--

Visit the Information Booth located at the lower level of each Terminal for additional information, or Call: 1-800-23-LOGAN TDD: 1-800-262-3325

**bostonlogan**

Airport Directory List - Bottom Panel





Boston Logan International Airport

i

Airport Directory

Welcome Troops

Located in Terminal Lower Level

**Map Legend**

Terminal	Elevator/Stair	Rampway	Cell Phone Lot	Airport Shuttle Route	Economy Parking	State Police	Gas Station	Cell Phone Lot	Hilton Hotel	Memorial	Car Rental Center	Logan Office Center	Massport Administration	Satellite	Hyatt Harborside Hotel	Fire Rescue Headquarters	South Cargo Area
----------	----------------	---------	----------------	-----------------------	-----------------	--------------	-------------	----------------	--------------	----------	-------------------	---------------------	-------------------------	-----------	------------------------	--------------------------	------------------

Chapin Lower Level Terminal  
 100 Lower Level Terminal  
 Foreign Exchange Terminal  
 Parking Violations and Security Badge Offices

### Information

**Ground Transportation Services**  
Ground Transportation connections are available at all Terminals. Ask curbside dispatchers or phone: 1-800-23-LOGAN, TTY 1-800-262-3325

**Information Booths**  
Ground Transportation and Foreign Language Assistance is available at the Massport Information Booths located in the Lower Level Baggage Claim area of all Terminals.

**Massachusetts State Police**  
Troop F, 617-568-7300

**Massport Fire Department**  
617-561-1900, 617-561-1901

Visit the Information Booth located at the lower level of each Terminal for additional information, or Call: 1-800-23-LOGAN TDD: 1-800-262-3335

### Airlines

**A** Alaska  
Delta  
Delta Shuttle

**B** Air Canada  
American  
PenAir  
Spirit  
US Airways

**C** Cape Air  
JetBlue  
United  
United Express

United  
Cleveland, Houston, Newark Departures

US Airways Express  
US Airways Shuttle  
Virgin America

**E** **All International Arrivals**  
*International Departures vary with Airline.*

Aer Lingus  
Air France  
AirTran  
Alitalia  
American  
International Arrivals Only  
British Airways  
CopaAirlines  
Delta  
International Arrivals Only  
Iberia  
Icelandair  
Japan Airlines  
JetBlue  
International Arrivals Only  
Lufthansa

Porter  
SATA  
Southwest  
Sun Country  
SWISS  
TACV  
Virgin Atlantic

Airport Directory Map



## Boston Logan International Airport



# Airline Directory



## Airlines

All International Arrivals at Terminal **E**

- |   |   |
|---|---|
| <b>E</b> Aer Lingus                               | <b>E</b> Lufthansa                                      |
| <b>B</b> Air Canada                               | <b>B</b> PenAir   |
| <b>E</b> Air France                               | <b>E</b> Porter   |
| <b>E</b> AirTran                                  | <b>E</b> SATA   |
| <b>A</b> Alaska                                   | <b>B</b> Spirit   |
| <b>E</b> Alitalia                                 | <b>E</b> Southwest                                      |
| <b>B</b> American (Except International Arrivals) | <b>E</b> Sun Country                                    |
| <b>E</b> American (International Arrivals Only)   | <b>E</b> Swiss  |
| <b>E</b> British Airways                          | <b>E</b> TACV   |
| <b>C</b> Cape Air                                 | <b>E</b> Turkish Airlines                               |
| <b>E</b> CopaAirlines                             | <b>C</b> United   |
| <b>A</b> Delta (Except International Arrivals)    | <b>A</b> United (Cleveland, Houston, Newark Departures) |
| <b>E</b> Delta (International Arrivals Only)      | <b>C</b> United Express                                 |
| <b>A</b> Delta Shuttle                            | <b>B</b> US Airways                                     |
| <b>E</b> Iberia                                   | <b>B</b> US Airways Express                             |
| <b>E</b> Icelandair                               | <b>B</b> US Airways Shuttle                             |
| <b>E</b> Japan Airlines                           | <b>B</b> Virgin America                                 |
| <b>C</b> JetBlue (Except International Arrivals)  | <b>E</b> Virgin Atlantic                                |
| <b>E</b> JetBlue (International Arrivals Only)    |   |

## Airport Services

- C** Airport Administration
- C** Chapel  
Logan Office Center (Use Airport Shuttle Route 66)
- C** Parking Violations Office  
Rental Cars (Use Airport Shuttle Routes 22, 33 or 55)
- C** Security Badge Office  
South Cargo (Use Airport Shuttle Route 66)  
State Police (Across the Street from the Airport Station)
- C** USO  
9/11 Memorial (Use Airport Shuttle to Terminal A. Access to Memorial via Pedestrian Connector to Hilton Hotel)

## Airport Shuttle

- Terminal **A** use Routes **22** or **55**
- Terminal **B** use Routes **22** or **55**
- Terminal **C** use Routes **22** or **55**
- Terminal **E** use Routes **22** or **55**
- Rental Car Facility use **22** **33** or **55**

Note: Airport Shuttle Route 66 stops at the Logan Boat Dock, then proceeds to all Terminals.

Visit the Information Booth located at the lower level of each Terminal for additional information, or Call: 1-800-23-LOGAN TDD: 1-800-262-3335

**bostonlogan**

## Airport Directory Airline List



Boston Logan International Airport



Located in Terminal A  
Lower Level

# Terminal Directory



**Map Legend**

- Restrooms
- Women's Restroom
- Men's Restroom
- Assisted Care/Nursing
- Elevator
- Escalator
- Information
- ATM/Cash Machine
- Baggage Claim
- Telephone
- Security Check
- Designated Smoking Area
- Petport
- Mailboxes
- Open 24 hours
- Automated External Defibrillator
- Parking Pay Station
- Post of Parking Per - Student before returning to car
- MSTA Ticket Machine
- Ticket Counter
- Post Security
- You Are Here

**Ground Transportation**

- Rental Car Center Shuttle
- Passenger Pick-up/Drop-off
- Logan Express/Scheduled Bus
- Airport Shuttle
- Taxi
- Shared Van/Courtesy Bus
- Silver Line
- Limos
- Charter Bus

Massachusetts State Police 911-562-7288  
Massport Fire Rescue/Medical Emergency 811-567-2022

A0415

Terminal A Directory Map Panel

Airport Services			Food			Shops		
Delta Baggage Claim Office	8	L1	Au Bon Pain	20	L2	Bead Factory	65	L2
Car Rental Telephone	10	L1	Auntie Anne's	33	S2	BookLink	63	L2
Classic Shoe Shine	2	L2	Dunkin' Donuts	37	L1	Brookstone	70	S2
Currency Exchange - Travelex	1	L2	Dunkin' Donuts	22	L2	Duty Free Americas	72	S2
Currency Exchange - Travelex	4	S2	Dunkin' Donuts	28	S2	Johnston & Murphy	73	S2
Delta Service Center	3	S2	Friendly's	21	S2	L'Occitane	68	S2
Delta Sky Club	6 11	S2	Fresh City	26	S2	Massachusetts State Lottery	74	L1
Hotel Information	9	L1	Game On! Sports Cafe	29	S2	New England Collections	82	L2
Kidport	5	S2	Harpoon Tap Room	32	S2	NewsLink	74	L1
Southwest Baggage Claim Office	12	L1	Legal Test Kitchen	25	L2	NewsLink	60 61 64	L2
TSA PreCheck Center	7	L2	Lucky's/Lucky's Express	24	L2	NewsLink	66 69 71	S2
			Phillips Seafood Express	27	S2	Tech Interaction	67	S2
			Sbarro	36	S2			
			Starbucks	34	S2			
			Wendy's	23	S2			
			Vino Volo	31	S2			

A0415

Visit the Information Booth located at the lower level of each Terminal for additional information, or Call: 1-800-23-LOGAN TDD: 1-800-282-3335

**bostonlogan**

Terminal A Directory Legend Panel

Terminal A Map



Boston Logan International Airport

B

Terminal Directory

welcometroops

Located in Terminal G Lower Level

**Map Legend**

	Restrooms		Baggage Claim		Automated External Defibrillator
	Women's Restroom		Telephone		Parking Pay Station
	Men's Restroom		Security Check		Pay at Parking Pay Station before entering lot
	Assisted Care/Nursing		Designated Smoking Area		MBTA Ticket Machine
	Elevator		Petport		Ticket Counter
	Escalator		Multibook		Post Security
	Information		Open 24hrs		You Are Here
	ATM/Cash Machine				

**Ground Transportation**

	Rental Car Center Shuttle		Passenger Pick-up/Drop-off		Logan Express/Sheduled Bus
	Airport Shuttle		Taxi		Shared Van/Courtesy Bus
	Silver Line		Limos		Charter Bus

Massachusetts State Police  
 Mississippi Fire Rescue Medical Emergency

**Level 2 (L2)**  
Ticketing & Gates

Central Parking Terminal G (via walkway at Level 2)

Terminal Parking P

Central Parking Terminal A (via sidewalk at Level 2)

**Level 1 (L1)**  
Baggage Claim & Ground Transportation

Terminal B Directory Map Panel B0515

Airport Services		
American Airlines Admirals Club	5	L2
American Airlines Federal Credit Union	1	L2
Baggage Claim Office	13 14 17	L1
Car Rental Telephone	14 18	L1
Currency Exchange - Travellex	4 9	L2
Federal Express Drop-Off	2	L2
Hotel Information	12 16 18	L1
Kidport	6	L2
Lost and Found	14 17	L1
Classic Shoe Shine	3 8 11	L2
United Club	7	L3
US Airways Club	10	L2
UPS Express Drop-Off	2	L2

Food		
Asian Too	44	L2
Au Bon Pain	40 46	L2
Berkshire Farms Market	35	L2
Cosi	20 23 49	L2
Cisco Brew Pub	29	L2
Dunkin' Donuts	28 30 38	L2
Espressamente Illy	36	L2
Home Team Sports	41	L2
Legal C Bar	31	L2
Legal Sea Foods	32 42	L2
McDonald's	22 45	L2
Ozone	39	L2
Peet's Coffee & Tea	33	L2
Ryo Asian Fusion	21	L2
Sbarro	47	L2
Starbucks	27 43 48	L2
Stephanie's	34	L2
Todd English's Bonfire	26	L2
UFood Grill	25	L2
Villa Pizza	24	L2
Vinea	37	L2

Shops		
Be Relax	59 73	L2
Boston AMERICA!	71	L2
Boston Tops	70 75	L2
Duty Free - International Shoppes	66 23 79	L2
Hudson	60 69 74	L2
Hudson	72 76 78	L2
Hudson	62 81	L2
InMotion Entertainment	77	L2
Johnston & Murphy	65	L2
Kieh's	67	L2
Local Charm	68	L2
Massachusetts State Lottery	62	L2
Metalsmiths Sterling	58	L2
Sunglass Hut	64	L2
Swatch	61	L2
Tech Showcase	63	L2

Terminal B Directory Legend Panel B05 15

Visit the Information Booth located at the lower level of each Terminal for additional information, or call: 1-800-23-LOGAN TDD: 1-800-262-3335

Terminal B Map



Boston Logan International Airport



# Terminal Directory

welcometroops US91  
 Located in Terminal C  
 Lower Level

**Map Legend**

Restrooms	Baggage Claim	Automated External Defibrillator
Women's Restroom	Telephone	Parking Pay Station <small>Pay at Parking Pay Station before returning to car.</small>
Men's Restroom	Security Check	MBTA Ticket Machine
Assisted Care/Nursing	Designated Smoking Area	Ticket Counter
Elevator	Pelipoint	Post Security
Escalator	Mailboxes	You Are Here
Information	Open 24hrs	
ATM/Cash Machine		

**Ground Transportation**

Rental Car Center Shuttle	Passenger Pick-up/Drop-off	Logan Express/Scheduled Bus
Airport Shuttle	Taxi	Shared Van/Courtesy Bus
Silver Line	Limos	Charter Bus

Massachusetts State Police  
 Phone 7 817-588-7282

Massport Fire Rescue Medical Emergency  
 817-567-2028

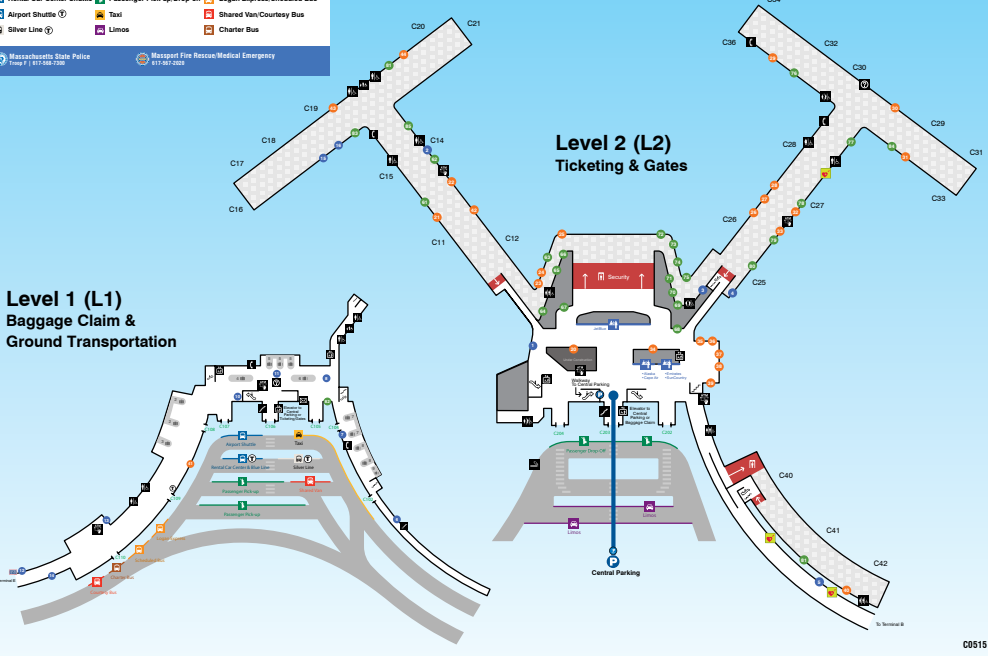

Terminal C Directory Map Panel

**Airport Services**

American Airlines Credit Union	13	L1
Car Rental Telephone	7 8	L1
Chapel	6	L1
Classique Hair Salon	1	L2
Currency Exchange - Travelex	16	L2
Hotel Phone Board	10	L1
Hotel Reservation Booth	11	L1
Kidport	3	L2
Lost and Found	5	L2
Security Badge/Parking Violations Office	14	L1
Classic Shoe Shine	2 4	L2
The Lounge	15	L2
USD Lounge	12	L1

**Food**

Au Bon Pain	20 42	L2
Boston Beer Works	22 33	L2
Burger King	38	L2
Currito	35	L2
Dunkin' Donuts	41	L1
Dunkin' Donuts	30 32 34 44	L2
Green Express	29	L2
Go Go Stop	31	L2
Jerry Remy's Bar and Grill	39	L2
Johnny Rockets	26	L2
Lean & Green Gourmet	40	L2 (Gates C-40-C42)
Legal Sea Foods	25	L2
Pinkberry	24	L2
Potbelly Sandwich Shop	21	L2
Ryo Asian Fusion	36	L2
Sbarro	37	L2
Starbucks	23 27	L2
Ufood Grill	43	L2
Wolfgang Puck Express	28	L2

**Shops**

Bead Factory	77	L2
Be Relax	73	L2
Best Buy Express	61 78	L2
Black Dog	65	L2
Duty Free - International Shoppes	83 80	L2
GoGo Gifts	84	L2
Hudson	82	L1
Hudson	62 64 70 76 79 81	L2
Hudson	68	L2
Hudson	81	L2 (Gates C40-C42)
iStore Boutique	66	L2
Kids Works	71	L2
Local Charm	85	L2
Life is Good	69	L2
Massachusetts State Lottery	82	L1
New England Collections	63	L2
Soundbalance	75	L2
Swatch	74	L2
Travel + Leisure	67	L2
Vineyard Vines	72	L2

Visit the Information Booth located at the lower level of each Terminal for additional information, or Call: 1-800-23-LOGAN TDD: 1-800-262-3335



Terminal C Directory Legend Panel

Terminal C Map



Boston Logan International Airport

E

Terminal Directory

**welcometroops**  
 Located in Terminal E  
 Lower Level

**Map Legend**

Restrooms	Baggage Claim	Automated External Defibrillator
Women's Restroom	Telephone	Parking Pay Station <small>Pay at Parking Pay Station before returning to car</small>
Men's Restroom	Security Check	MBTA Ticket Machine
Assisted Care/Nursing	Designated Smoking Area	Ticket Counter
Elevator	Post Office	Post Security
Escalator	Mailboxes	You Are Here
Information	Open 24 hours	
ATM/Cash Machine		

**Ground Transportation**

Rental Car Center Shuttle	Passenger Pick-up/Drop-off	Logan Express/Shared Bus
Airport Shuttle	Taxi	Shared Van/Courtesy Bus
Silver Line	Limos	Charter Bus

Massachusetts State Police  
 Phone F | 617-558-7200

Massport Fire/Rescue/Medical Emergency  
 617-561-2120

**Level 1 (L1)**  
 Baggage Claim &  
 Ground Transportation

**Level 2 (L2)**  
 Gates

**Level 3 (L3)**  
 Ticketing & Gates

**Airport Services**

Aer Lingus Gold Circle Club	13 (passenger)	L3
Air France Affaires Lounge	11 (passenger)	L3
Baggage Transfer	3	L1
British Airways Terraces Lounge	13 (passenger)	L3
Car Rental Telephone	1 7	L1
Currency Exchange-Travellex	9	L1
Currency Exchange-Travellex	10 12	L3
Customs Office	2	L1
Global Entry Office	4	L1
Hotel Information	1	L1
International Arrivals Area	11	L1
Lufthansa Senator & Business Lounge	13 (passenger)	L3
Virgin Atlantic Clubhouse	13 (passenger)	L3

**Food**

Burger King	22	L3
Dine Boston Restaurant	32	L3
Dine Boston Cafe	31	L3
Dunkin' Donuts	33	L1
Durkin Park Restaurant	20	L3
Earl of Sandwich	25	L3
Sbarro	24	L3
Starbucks	23	L3
Vino Volo	21	L3

**Shops**

Best Buy Express	68	L3
Brookstone	72	L3
Clinique Estee Lauder	76	L3
Duty Free - International Shoppes	63 75	L3
Hudson News	76	L1
Hudson News	69	L2
Hudson News	61 67 74	L3
Hugo Boss	66	L3
Kieh's	62	L3
Massachusetts State Lottery	76	L1
Michael Kors	65	L3
Mont Blanc	64	L3
Tech Showcase	73	L3
Travel + Leisure	60	L3

Visit the Information Booth located at the lower level of each Terminal for additional information, or  
 Call: 1-800-23-LOGAN TDD: 1-800-262-3335

**bostonlogan**

Terminal E Map

2015

Wayfinding Guideline & Sign Standards 4-26

Boston Logan International Airport



Parking - Central Parking - Left

Boston Logan International Airport

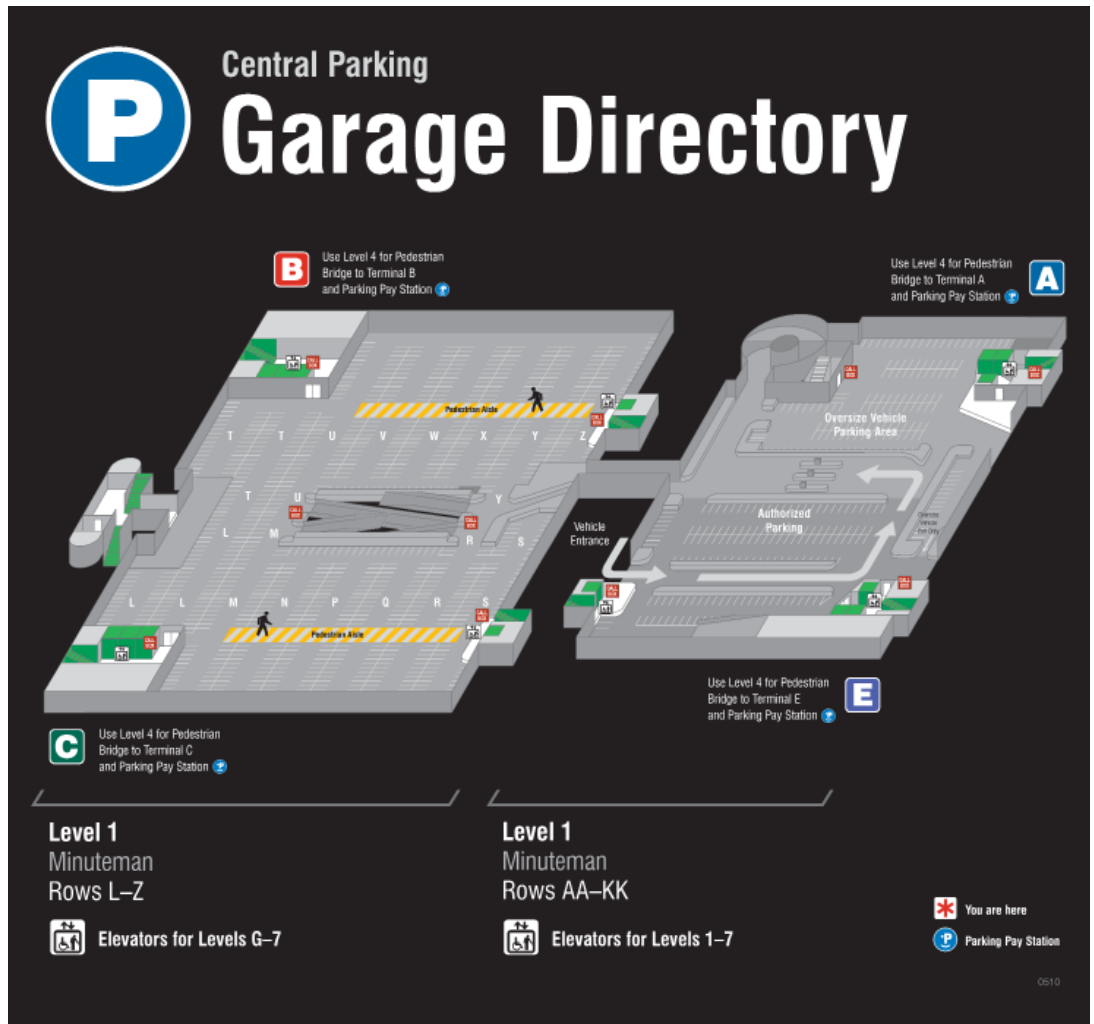

Parking - Central Parking - Right

**Central Parking Services**

**Security/Emergency Help**  
Central Parking is patrolled by Massport Parking Attendants and Massachusetts State Police. Emergency call boxes are located next to elevators and in other prominent locations – look for red signs.

**Vehicle Assistance**  
If you require assistance for any of the following: dead battery, lockouts, lost car searches, deflated or flat tires, please contact the Garage Office at 617-561-1673 or use the emergency call boxes located throughout Central Parking. The service is free – no tipping please.

**Towed Vehicles**  
If your car is towed, go to the Garage Office located near the Exit lanes on Level 2. (Use Terminal E elevator.)

**Garage Shuttle**  
Complimentary shuttle service is available on Level 4.

**Customer Comments:** Call 617-561-1989

**Central Parking Pedestrian Access**

**Garage Shuttle Service**  
The pedestrian crossover of the garage is located on Level 4. Bridge to Hilton Hotel at Level 2. (Use Terminal A elevator.)

**Parking Pay Station on Level 4.**  
Pay at Parking Pay Station before returning to car.

**You are here** (Red asterisk icon)

<p><b>Parking Rows L-Z (single letter rows)</b></p> <ul style="list-style-type: none"> <li>Level 7: Max's Shed</li> <li>Level 6: Cape Cod</li> <li>Level 5: Paul Revere</li> <li>Level 4: U.S.G. Constitution</li> <li>Level 3: Boston Marathon</li> <li>Level 2: Swan Boats</li> <li>Level 1: Minuteman</li> <li>Level 6 (rows 1-16): Gloucester Fisherman</li> </ul>	<p><b>Parking Rows AA-KK (double letter rows)</b></p> <ul style="list-style-type: none"> <li>Level 7: Max's Shed</li> <li>Level 6: Cape Cod</li> <li>Level 5: Paul Revere</li> <li>Level 4: U.S.G. Constitution</li> <li>Level 3: Boston Marathon</li> <li>Level 2: Swan Boats</li> <li>Level 1: Minuteman</li> </ul>
--	---

0608

Parking - Central Garage - Bottom Panel





Boston Logan International Airport

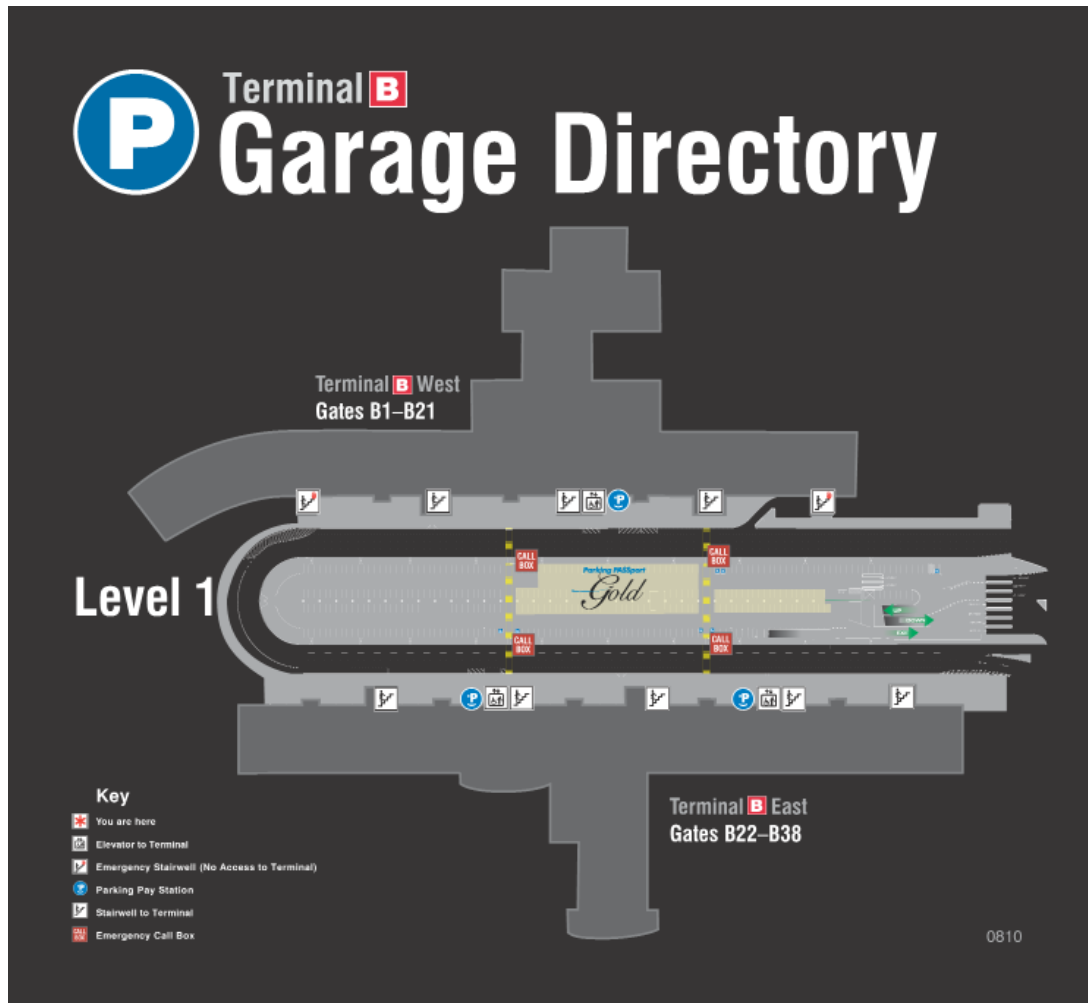

Parking - Terminal B Garage - Map

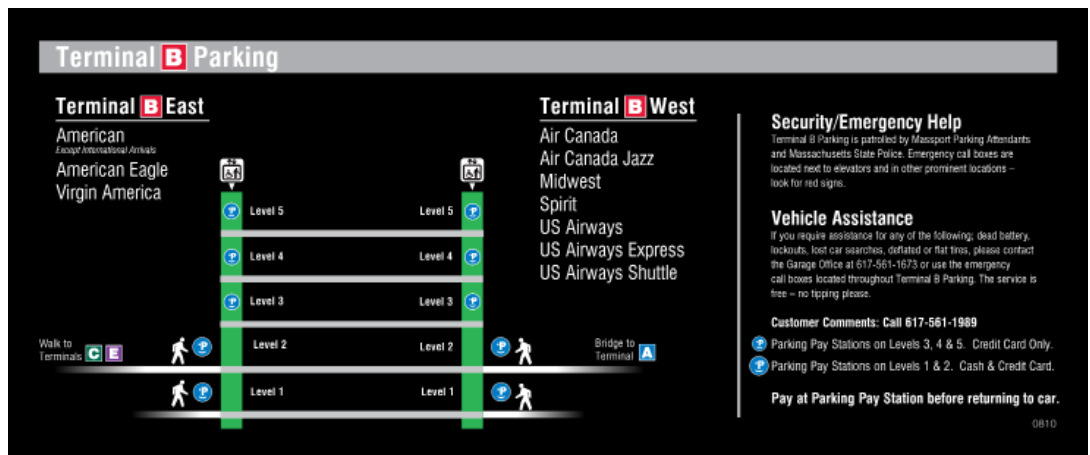

Parking - Terminal B Garage - Bottom Panel



Boston Logan International Airport



Parking - Economy Parking - Map

Boston Logan International Airport



# Ground Transportation



## Shuttles



Use Yellow Airport Shuttle Routes

<p><b>11</b> <b>A B C E</b> Terminals A B C E</p>	<p><b>22</b> <b>A B</b> <b>T</b> Terminals A B Rental Car Center MBTA Blue Line</p>	<p><b>55</b> <b>A B C E</b> <b>T</b> Terminals A B C E Rental Car Center MBTA Blue Line</p>
<p><b>33</b> <b>C E</b> <b>T</b> Terminals C E Rental Car Center MBTA Blue Line</p>	<p><b>66</b> <b>A B C E</b> <b>T</b> Logan Boat Dock Terminals A B C E MBTA Blue Line Logan Office Center</p>	<p><b>88</b> <b>P A B C E</b> Economy Parking Terminal A B C E</p>



### Hotel Buses and Vans

Service available at Courtesy Bus stop.

## **T** MBTA Services



### MBTA Silver Line **T**

Serving Boston's Convention Center & South Station.  
Service is Free from the Airport.  
Proceed to Silver Line bus stop at Terminal curb.



### MBTA Blue Line **T**

Use **22** **33** **55** or **66** Shuttle to Airport Station.



### MBTA Harbor Express **T**

Tickets sold aboard vessels.  
Scheduled service between Quincy/Hull, Downtown Boston (Long Wharf).  
Use **66** Shuttle to Logan Boat Dock.

## **B** Buses



### Logan Express

Serving Braintree, Framingham, Peabody, Woburn.  
Proceed to Logan Express bus stop at Terminal curbside.



### Courtesy Bus and Shared Van

Frequent service available to area hotels.



### Scheduled Bus

Serving New England.  
Proceed to the Scheduled bus stop at Terminal curbside.



### Charter Bus

Proceed to the Charter bus stop at Terminal curbside.



## Water Transportation

Year-round, On-demand service to and from the Logan Boat Dock.  
Use **66** Shuttle to Logan Boat Dock.

### City Water Taxi

Serves locations throughout Boston Harbor.  
(617) 422-0392

### Rowes Wharf Water Transport

Serves Rowes Wharf and locations throughout Boston Harbor.  
(617) 406-8584

Visit the Information Booth located at the lower level of each Terminal for additional information, or Call: 1-800-23-LOGAN TDD: 1-800-262-3335



## Ground Transportation



Boston Logan International Airport









# Making Connections

*How do I get to...*



Boston Logan International Airport  
1,000 ft. or a 5 min. walk

<i>Best Bet</i>	<i>Alternate</i>
<div style="display: flex; align-items: center; margin-bottom: 10px;"> <div style="background-color: red; color: white; padding: 10px; font-size: 2em; margin-right: 10px;">B</div> <div>  <p><b>Turn right.</b> Use elevator to Level 3. <small>(Less than .2 miles or a 6-minute walk.)</small></p> </div> </div>	<div style="display: flex; align-items: center; margin-bottom: 10px;"> <div style="background-color: blue; color: white; padding: 5px; font-size: 1.2em; margin-right: 5px;">  </div> <div> <p><b>Airport Shuttle</b></p> <p>Proceed to curbside.</p> <p>Airport Shuttle Routes <span style="background-color: yellow; border-radius: 50%; padding: 2px 5px;">11</span> or <span style="background-color: yellow; border-radius: 50%; padding: 2px 5px;">55</span></p> </div> </div>
<div style="display: flex; align-items: center; margin-bottom: 10px;"> <div style="background-color: green; color: white; padding: 10px; font-size: 2em; margin-right: 10px;">C</div> <div> <div style="display: flex; align-items: center; margin-bottom: 5px;"> <div style="background-color: blue; color: white; padding: 5px; font-size: 1.2em; margin-right: 5px;">  </div> <div> <p><b>Airport Shuttle</b></p> <p>Proceed to curbside.</p> <p>Airport Shuttle Routes <span style="background-color: yellow; border-radius: 50%; padding: 2px 5px;">11</span> or <span style="background-color: yellow; border-radius: 50%; padding: 2px 5px;">55</span></p> </div> </div> </div> </div>	<div style="display: flex; align-items: center; margin-bottom: 10px;"> <div style="margin-right: 10px;">  </div> <div> <p><b>Walking is NOT recommended.</b> <small>(See directions to Terminal B.)</small></p> </div> </div>
<div style="display: flex; align-items: center; margin-bottom: 10px;"> <div style="background-color: purple; color: white; padding: 10px; font-size: 2em; margin-right: 10px;">E</div> <div>  <p><b>Turn left.</b> Use elevator to Level 3. <small>(Less than .4 miles or a 11-minute walk.)</small></p> </div> </div>	<div style="display: flex; align-items: center; margin-bottom: 10px;"> <div style="background-color: blue; color: white; padding: 5px; font-size: 1.2em; margin-right: 5px;">  </div> <div> <p><b>Airport Shuttle</b></p> <p>Proceed to curbside.</p> <p>Airport Shuttle Routes <span style="background-color: yellow; border-radius: 50%; padding: 2px 5px;">11</span> or <span style="background-color: yellow; border-radius: 50%; padding: 2px 5px;">55</span></p> </div> </div>



Visit the Information Booth located at the lower level of each Terminal for additional information, or  
Call: 1-800-23-LOGAN TDD: 1-800-262-3335



**Making Connections**



Boston Logan International Airport

---



Parking Gold Pass Logo



Lexus Parking Gold Pass Logo

Boston Logan International Airport

---



Clean Vehicle Logo



Massachusetts State Police Logo

Boston Logan International Airport

---



Massport Fire Rescue Logo

Boston Logan International Airport

---



Infobar Logo



Boston Logan International Airport

---



U.S. Customs Border Protection - ESTA Visa Waver Program

Boston Logan International Airport

---

**Non-U.S. Citizens & Visitors**  
Use Blue Lanes

Visitantes extranjeros - Use las líneas azules

Ausländische Besucher - Den blauen Spuren folgen

Visitantes estrangeiros - Usar faixas azuis

Visitatori stranieri - Usare le corsie blu

外国旅客 - 请使用蓝色通道

विदेशी आगंतुक - नीली लेन का उपयोग करें

Visiteurs étrangers - Utilisez les files bleues

外国からの訪問者 - 青色のレーンをご利用ください

الزوار الأجانب - استخدم الممرات الزرقاء

מבקרים בעלי דרכון זר - עברו במסלולים הכחולים

A.B.D Vatandaşları - Kırmızı Şeritleri Kullanın

**U.S. Customs Border Protection - Message Translation Program**

Boston Logan International Airport

---

**Lawful Permanent  
Residents (Green Card)**  
Use Green Lanes

**Message Translation Program - U.S. Customs Border Protection**

Boston Logan International Airport

**Diplomats, Crew & **  
Use Orange Lanes

Diplomáticos - Use las líneas anaranjadas  
Diplomaten - Den orangen Spuren folgen  
Diplomatas - Usar faixas laranjas  
Personale diplomatico - Usare le corsie arancioni  
外交官 - 使用橙色通道  
राजनयिक - बरिच लेन का इस्तेमाल करें  
Diplomates - Utilisez les files oranges  
外交官 - オレンジ色のレーンを使用  
الدبلوماسيون - استخدم المعزلت البرتقالية  
דיפלומטן - שימוש באורנג'י ליי  
Diplomatlar - Turuncu Şeritleri Kullanın

Message Translation Program - U.S. Customs Border Protection

Boston Logan International Airport

---

**U.S. & Canadian  
Passports Only (No Visa)**  
Use Red Lanes

**Message Translation Program - U.S. Customs Border Protection**



## Section 5

### Typical Sign Faces

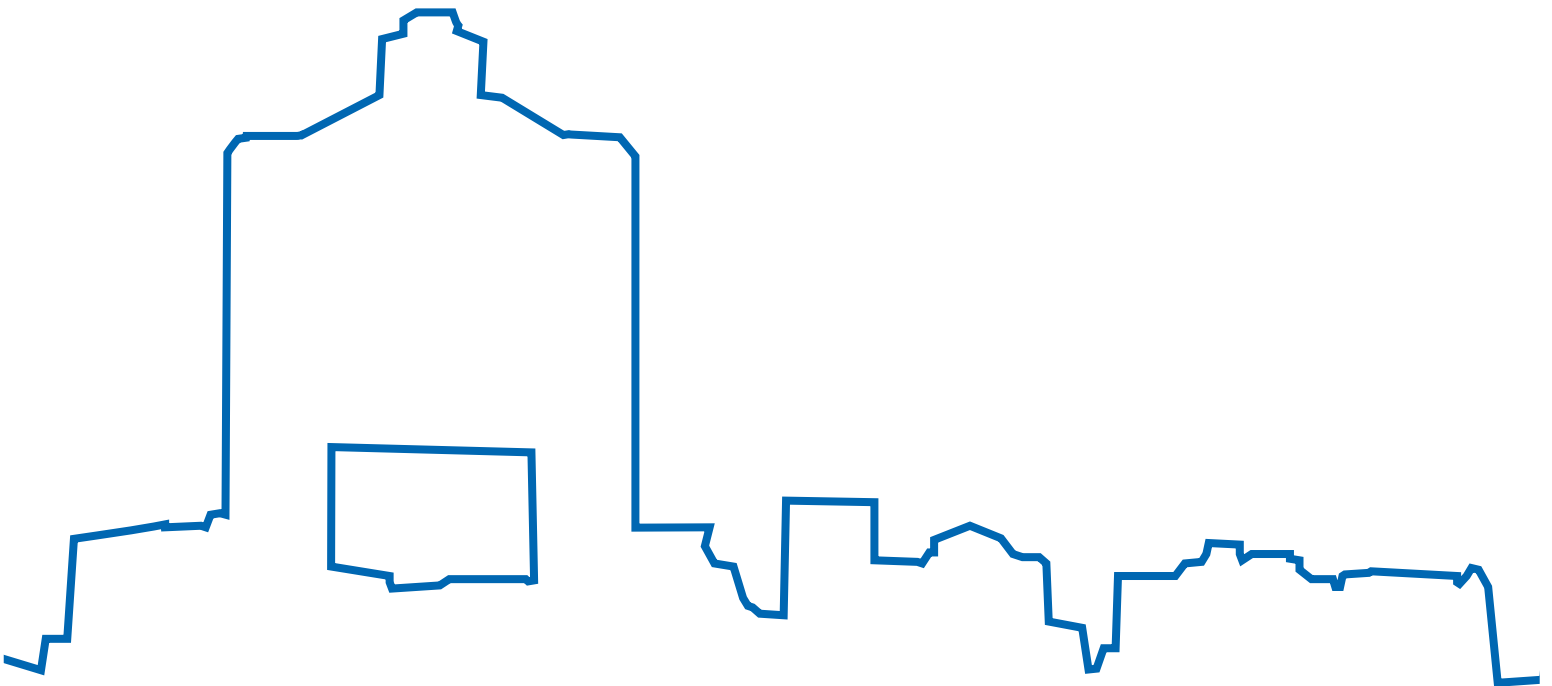

A series of standard sign faces have been developed for each area of the airport and should be the basis for design when implementing any portion of the wayfinding signage system. Each sign face is assigned a five-digit reference number that should be included in the message schedule.

**100 SERIES - TERMINALS**

101 - 150	Directional
151 - 180	Identification
181 - 199	Informational

**200 SERIES - CURBSIDE**

201 - 250	Directional
251 - 280	Identification
281 - 299	Informational

**300 SERIES - PARKING**

301 - 350	Directional
351 - 380	Identification
381 - 399	Informational

**400 SERIES - ROADWAY**

401 - 450	Directional
451 - 480	Identification
481 - 499	Informational

**500 SERIES - AIRPORT SERVICE BUILDINGS**

501 - 550	Directional
551 - 580	Identification
581 - 599	Informational

**600 SERIES - FIRE AND LIFE SAFETY**

## 5.1 TERMINALS

### 100 SERIES

101 - 150	Directional
151 - 180	Identification
181 - 199	Informational



**Directional**

**ST-101 TERMINALS - DIRECTIONAL**

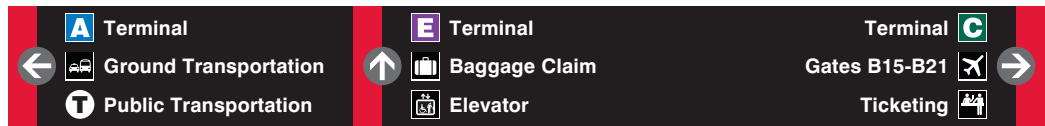

- Three directional, three levels of messaging
- Used in circulation corridors perpendicular to main pedestrian traffic flow
- Used for both primary and secondary information
- Non-illuminated or illuminated
- Face size shown: 2'-1"H x 18'-0"L
- Applicable Sign Box Types: A-3, B-3, A-3-I, B-3-I
- 3" cap height
- 6" symbol
- 8" arrow
- 6" color band

**ST-102 TERMINALS - DIRECTIONAL**

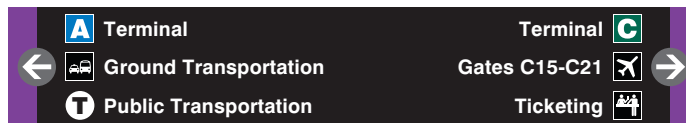

- Two directional, three levels of messaging
- Used in circulation corridors perpendicular to main pedestrian traffic flow
- Used for both primary and secondary information
- Non-illuminated or illuminated
- Face size shown: 2'-1"H x 12'-0"L
- Applicable Sign Box Types: A-2, B-2, C-2, A-2-I, B-2-I, C-2-I
- 3" cap height
- 6" symbol
- 8" arrow
- 6" color band

**ST-103 TERMINALS - DIRECTIONAL**

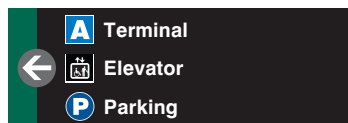

- One directional, three levels of messaging
- Used in circulation corridors perpendicular to main pedestrian traffic flow
- Non-illuminated or illuminated
- Used for both primary and secondary information
- Face size shown: 2'-1"H x 6'-0"L
- Applicable Sign Box Types: A-1, B-1, C-1, A-1-I, B-1-I, C-1-I
- 3" cap height
- 6" symbol
- 8" arrow
- 6" color band

ST-104 TERMINALS - DIRECTIONAL

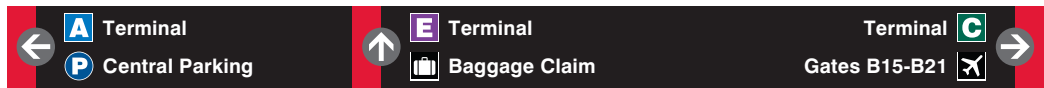

- Three directional, two levels of messaging
- Used in circulation corridors perpendicular to main pedestrian traffic flow
- Used for both primary and secondary information
- Non-illuminated or illuminated
- Face size shown: 1'-5"H x 18'-0"L
- Applicable Sign Box Types: A-3, B-3, A-3-I, B-3-I
- 3" cap height
- 6" symbol
- 8" arrow
- 6" color band

ST-105 TERMINALS - DIRECTIONAL



- Two directional, two levels of messaging
- Used in circulation corridors perpendicular to main pedestrian traffic flow
- Used for both primary and secondary information
- Non-illuminated or illuminated
- Face size shown: 1'-5"H x 12'-0"L
- Applicable Sign Box Types: A-2, B-2, C-2, A-2-I, B-2-I, C-2-I
- 3" cap height
- 6" symbol
- 8" arrow
- 6" color band

ST-106 TERMINALS - DIRECTIONAL

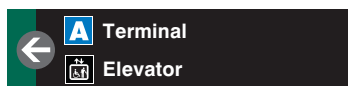

- One directional, two levels of messaging
- Used in circulation corridors perpendicular to main pedestrian traffic flow
- Used for both primary and secondary information
- Non-illuminated or illuminated
- Face size shown: 1'-5"H x 6'-0"L
- Applicable Sign Box Types: A-1, B-1, C-1, A-1-I, B-1-I, C-1-I
- 3" cap height
- 6" symbol
- 8" arrow
- 6" color band

ST-107 TERMINALS - DIRECTIONAL



- Three directional, one level of messaging
- Used in circulation corridors perpendicular to main pedestrian traffic flow
- Non-illuminated or illuminated
- Used for both primary and secondary information
- Face size shown: 0'-9"H x 18'-0"L
- Applicable Sign Box Types: A-3, B-3, A-3-I, B-3-I
- 3" cap height
- 6" symbol
- 7" arrow
- 6" color band

ST-108 TERMINALS - DIRECTIONAL



- Two directional, one level of messaging
- Used in circulation corridors perpendicular to main pedestrian traffic flow
- Non-illuminated or illuminated
- Used for both primary and secondary information
- Face size shown: 0'-9"H x 12'-0"L
- Applicable Sign Box Types: A-2, B-2, C-2, A-2-I, B-2-I, C-2-I
- 3" cap height
- 6" symbol
- 7" arrow
- 6" color band

ST-109 TERMINALS - DIRECTIONAL

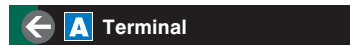

- One directional, one level of messaging
- Used in circulation corridors perpendicular to main pedestrian traffic flow
- Used for both primary and secondary information
- Non-illuminated or illuminated
- Face size shown: 0'-9"H x 6'-0"L
- Applicable Sign Box Types: A-1, B-1, C-1, A-1-I, B-1-I, C-1-I
- 3" cap height
- 6" symbol
- 7" arrow
- 6" color band

## ST-121 TERMINALS - DIRECTIONAL



- Two directional, three levels of messaging
- Used in circulation corridors perpendicular to main pedestrian traffic flow
- Used for primary information
- Illuminated
- Variable Message System Display
- Face size shown: 2'-1"H x 12'-0"L
- Applicable Sign Box Type: D-121
- 3" VMS cap height
- 8" arrow
- 6" color band

## ST-128 TERMINALS - DIRECTIONAL

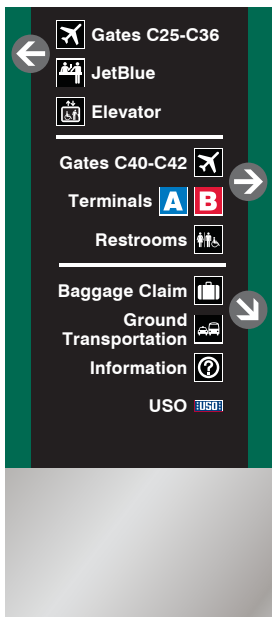

- Used in circulation corridors perpendicular to main pedestrian traffic flow
- Used for secondary information
- Non-illuminated
- Face size shown: 6'-0"H x 3'-6"L
- Overall size: 8'-0"H x 3'-6"L
- Applicable Sign Box Type: prefabricated freestanding sign\*
- 2" cap height
- 4-1/2" symbol
- 6" arrow
- 4" color band
- 1/2" rule line

\* *These signs are not mounted to the floor, but sit on the ground and are moveable.*

## Identification

### ST-153 TERMINALS - IDENTIFICATION



- Gate ID - Airline Listing
- Used at primary gate area entrances prior to security check points
- Used for primary information
- Illuminated
- Variable Message System Display
- Face size shown: 2'-4"H x 13'-4"L
- Applicable Sign Box Type: D-153
- 3" VMS cap height
- 6" cap height
- 2'-4" terminal symbol

### ST-154 TERMINALS - IDENTIFICATION



- Gate ID
- Used at gate hold room locations
- Used for secondary information
- Non-illuminated or illuminated
- Face size shown: 1'-4"H x 2'-8"L
- Applicable Sign Box Types: G-2 (non-illuminated), A-1-I (illuminated)
- 3" cap height
- 7" gate number
- 1'-4" terminal symbol

ST-155 TERMINALS - IDENTIFICATION



- Services ID
- Used at locations of services (i.e. restroom, telephone, elevator)
- Used for secondary information
- Non-illuminated
- Overall Size: 1'-4"H x 1'-4"L x 0'-3"D
- Applicable Sign Box Type: F-1

ST-156 TERMINALS - IDENTIFICATION

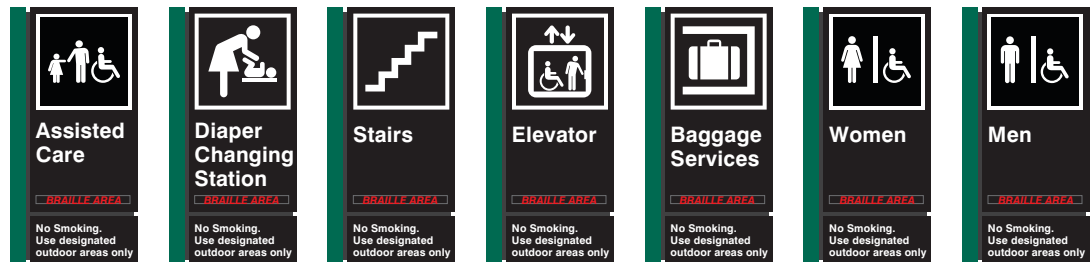

- Services ID with braille
- Used at location of services and stairs
- Used for secondary information
- Non-illuminated
- Overall Size: 1'-4"H x 0'-8"L
- Primary Panel Size: 1'-0 3/4"H x 0'-6 3/4"L
- Secondary Panel Size: 3'-0"H x 0'-3"L
- Applicable Sign Box Type: G-1
- 1" primary cap height
- 1/2" secondary cap height
- 6" symbol
- 1" color band
- 1/4" reveal

*Reveal shown as gray for illustrative purposes. Color to be black.  
Braille area shown as outline on sign only. Braille to comply with ADA.*

ST-157 TERMINALS - IDENTIFICATION



*Reveal shown as gray for illustrative purposes. Color to be black.  
Braille area shown as outline on sign only. Braille to comply with ADA.*

- Level ID with braille
- Used at locations in proximity to stairs to identify level
- Used for secondary information
- Non-illuminated
- Overall Size: 1'-0"H x 0'-8"L
- Primary Panel Size: 0'-8"H x 0'-6 3/4"L
- Secondary Panel Size: 0'-3 3/4"H x 0'-6 3/4"L
- Applicable Sign Box Type: G-1
- 6" floor number
- 1" cap height
- 1" color band
- 1/4" reveal

ST-158 TERMINALS - IDENTIFICATION

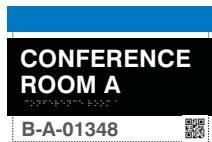

*Color band to be the color of the terminal location.  
Braille to comply with ADA.*

- Room ID with braille
- Used at room entrances
- Used for secondary information
- Non-illuminated
- Overall Size: 4 3/8"H x 9"L
- Applicable Sign Box Type: G-3
- 5/8" room number
- 3/4" cap height
- 1 1/4" color band
- 1/4" reveal
- Lower Panel Optional

ST-160 TERMINALS - IDENTIFICATION

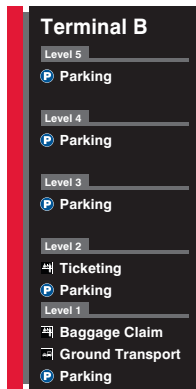

- Elevator Plaque
- Used inside elevator cabs
- Used for secondary information
- Non-illuminated
- Overall Size: 2'-0"H x 1'-0"L
- Applicable Sign Box Type: G-1
- 1" terminal cap height
- 5/8" cap height
- 3/4" symbol
- 1" color band
- 3/8" reveal
- 1/4 rule line

*Reveal shown as gray for illustrative purposes. Color to be black.*

ST-161 TERMINALS - IDENTIFICATION



- Baggage Claim ID
- Used at Baggage Claim carousels
- Used for secondary information
- Non-illuminated
- Overall Size: 1'-4"H x 2'-0"L x 0'-3"D
- Applicable Sign Box Types: F-3, F-4
- 9" cap height
- 10" symbol
- 2 1/2" color band
- 1/4" reveal

*Reveal shown as gray for illustrative purposes. Color to be black.*



## ST-163 TERMINALS - IDENTIFICATION



- Massport Door ID Plaque with braille
- Used at Massport office doors
- Used for secondary information
- Non-illuminated
- Overall Size: 4 3/8"H x 9"L
- Applicable Sign Box Type: G-3
- 5/8" room number
- 3/4" cap height
- 1 1/4" color band
- 1/4" reveal
- Lower Panel Optional

## ST-164 TERMINALS - IDENTIFICATION

# Information

- Information Booth Header
- Used at Information Booths
- Used for secondary information
- Non-illuminated
- Size: 4 1/2"H
- Applicable Sign Box Type: S-164
- 4 1/2" cap height

## ST-165 TERMINALS - IDENTIFICATION



- Exterior Gate ID
- Used at doors to outside of building to identify gates
- Used for secondary information
- Illuminated
- Face size shown: 1'-8"H x 3'-4"L
- Applicable Sign Box Types: B-1-I (illuminated)
- 1'-0" cap height
- 3" color band

## Informational

## ST-181 TERMINALS - INFORMATIONAL

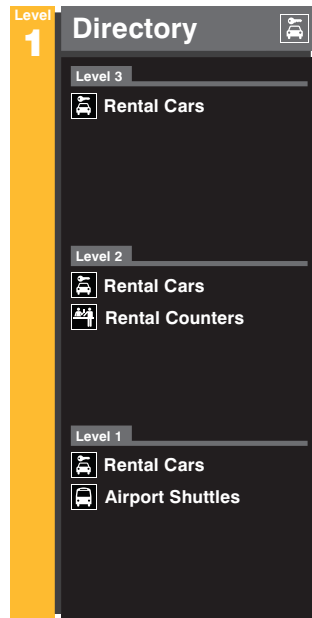

*Reveal shown as gray for illustrative purposes. Color to be black.*

- Elevator Directory
- Used at elevator locations
- Used for primary and secondary information
- Non-illuminated
- Interior artwork
- Overall Size: 4'-0"H x 2'-0"L
- Applicable Sign Box Type: G-1
- 3/4" cap height - the word "Level" at vertical color band
- 2" cap height - level number at vertical color band
- 1 1/2" header cap height
- 3/4" cap height - floor level and number at gray box
- 1" cap height - message
- 2" symbol
- 3 1/2" color band
- 3 1/2" header band
- 1 5/8" x 4 3/4" gray box
- 1/2" reveals
- 3/8" rule line

## ST-182 TERMINALS - INFORMATIONAL

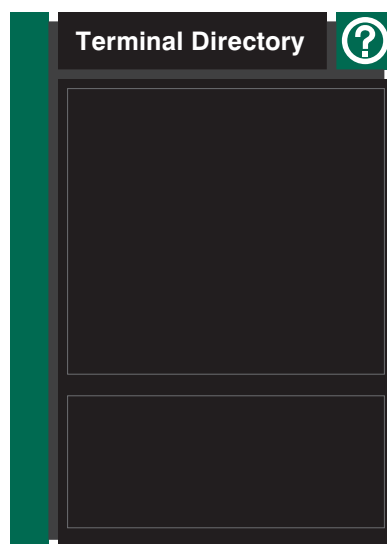

*Reveal shown as gray for illustrative purposes. Color to be black.*

- Terminal Directory
- Used in primary circulation corridors parallel to main pedestrian traffic flow
- Used for primary and secondary information
- Non-illuminated
- Interior artwork
- Overall Size: 4'-8"H x 3'-4"L
- Applicable Sign Box Type: G-1
- 2" header cap height
- 2 1/2" symbol
- 5" symbol height
- 4" color band
- 6" header band
- 1/2 reveals

ST-183 TERMINALS - INFORMATIONAL



- Terminal Directory
- Used in primary circulation corridors parallel to main pedestrian traffic flow
- Used for primary and secondary information
- Digital Signage

ST-184 TERMINALS - INFORMATIONAL



- Information Directory
- Used at Information Booths
- Used for primary and secondary information
- Non-illuminated
- Removable message panels
- Overall Size: 3'-4"H x 2'-8"L
- Applicable Sign Box Type: S-184
- 1" cap height
- 2" header cap height
- 4" symbol
- 3 1/2" color band
- 5" header band

*Reveal shown as gray for illustrative purposes. Color to be black.*

## 5.2 CURBSIDE

### 200 SERIES

201 - 250	Directional
251 - 280	Identification
281 - 299	Informational

**Directional**

**ST-201 CURBSIDE - DIRECTIONAL - PEDESTRIAN**



- Three directional, three levels of messaging
- Used in circulation corridors perpendicular to main pedestrian traffic flow
- Used for primary information
- Non-illuminated or illuminated
- Face size shown: 2'-1"H x 18'-0"L
- Applicable Sign Box Types: A-3, B-3, A-3-I, B-3-I
- 3" cap height
- 6" symbol
- 8" arrow
- 7 1/2" header band
- 6" color band

**ST-202 CURBSIDE - DIRECTIONAL - PEDESTRIAN**



- Two directional, three levels of messaging
- Used in circulation corridors perpendicular to main pedestrian traffic flow
- Used for primary information
- Non-illuminated or illuminated
- Face size shown: 2'-1"H x 12'-0"L
- Applicable Sign Box Types: A-2, B-2, A-2-I, B-2-I
- 3" cap height
- 6" symbol
- 8" arrow
- 7 1/2" header band
- 6" color band

**ST-203 CURBSIDE - DIRECTIONAL - PEDESTRIAN**

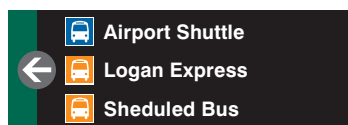

- One directional, three levels of messaging
- Used in circulation corridors perpendicular to main pedestrian traffic flow
- Non-illuminated or illuminated
- Used for primary information
- Face size shown: 2'-1"H x 6'-0"L
- Applicable Sign Box Types: A-1, B-1, A-1-I, B-1-I
- 3" cap height
- 6" symbol
- 8" arrow
- 7 1/2" header band
- 6" color band

ST-204 CURBSIDE - DIRECTIONAL - PEDESTRIAN

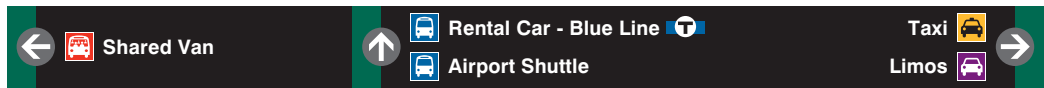

- Three directional, two levels of messaging
- Used in circulation corridors perpendicular to main pedestrian traffic flow
- Used for primary information
- Non-illuminated or illuminated
- Face size shown: 1'-5"H x 18'-0"L
- Applicable Sign Box Types: A-3, B-3, A-3-I, B-3-I
- 3" cap height
- 6" symbol
- 8" arrow
- 7 1/2" header band
- 6" color band

ST-205 CURBSIDE - DIRECTIONAL - PEDESTRIAN



- Two directional, two levels of messaging
- Used in circulation corridors perpendicular to main pedestrian traffic flow
- Used for primary information
- Non-illuminated or illuminated
- Face size shown: 1'-5"H x 12'-0"L
- Applicable Sign Box Types: A-2, B-2, A-2-I, B-2-I
- 3" cap height
- 6" symbol
- 8" arrow
- 7 1/2" header band
- 6" color band

ST-206 CURBSIDE - DIRECTIONAL - PEDESTRIAN

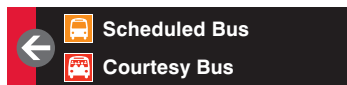

- One directional, two levels of messaging
- Used in circulation corridors perpendicular to main pedestrian traffic flow
- Non-illuminated or illuminated
- Used for primary information
- Face size shown: 1'-5"H x 6'-0"L
- Applicable Sign Box Types: A-1, B-1, A-1-I, B-1-I
- 3" cap height
- 8" symbol
- 6" arrow
- 7 1/2" header band
- 6" color band

## ST-207 CURBSIDE - DIRECTIONAL - PEDESTRIAN



- Three directional, one level of messaging
  - Used in circulation corridors perpendicular to main pedestrian traffic flow
  - Used for primary information
  - Non-illuminated or illuminated
  - Face size shown: 0'-9"H x 18'-0"L
  - Applicable Sign Box Types: A-3, B-3, A-3-I, B-3-I
- 3" cap height
  - 6" symbol
  - 7" arrow
  - 7 1/2" header band
  - 6" color band

## ST-208 CURBSIDE - DIRECTIONAL - PEDESTRIAN



- Two directional, one level of messaging
  - Used in circulation corridors perpendicular to main pedestrian traffic flow
  - Used for primary information
  - Non-illuminated or illuminated
  - Face size shown: 0'-9"H x 12'-0"L
  - Applicable Sign Box Types: A-2, B-2, A-2-I, B-2-I
- 3" cap height
  - 6" symbol
  - 7" arrow
  - 7 1/2" header band
  - 6" color band

## ST-209 CURBSIDE - DIRECTIONAL - PEDESTRIAN



- One directional, one level of messaging
  - Used in circulation corridors perpendicular to main pedestrian traffic flow
  - Non-illuminated or illuminated
  - Used for primary information
  - Face size shown: 0'-9"H x 6'-0"L
  - Applicable Sign Box Types: A-1, B-1, A-1-I, B-1-I
- 3" cap height
  - 8" symbol
  - 7" arrow
  - 7 1/2" header band
  - 6" color band

ST-213 CURBSIDE - DIRECTIONAL - PEDESTRIAN

---

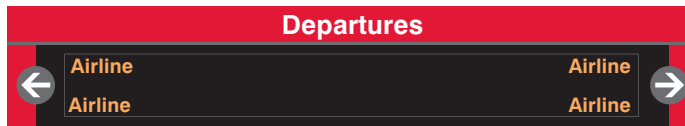

- Directional Airline Listing
  - Two directional, two levels of messaging
  - Used at the curbside between the two facilities of Terminal B perpendicular to the main pedestrian traffic
  - Used for primary information
  - Non-Illuminated
  - Variable Message System Display
  - Face size shown: 2'-1"H x 12'-0"L
  - Applicable Sign Box Type: D-213
- 3" VMS cap height
  - 4" header cap height
  - 8" arrow
  - 7 1/2" header band
  - 6" color band
  - 1/2" rule line



ST-214 CURBSIDE - DIRECTIONAL - PEDESTRIAN

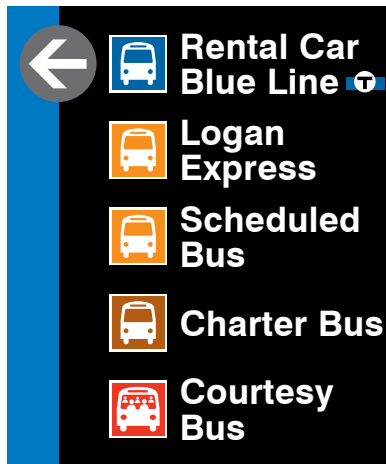

- Ground Transportation Directional
- One directional, five levels of messaging
- Used at Arrivals Level curbsides
- Used for primary information
- Non-Illuminated
- Face size shown: 3'-0"H x 2'-6"L
- Applicable Sign Box Type: H
- 2" cap height
- 4-1/2" symbol
- 6" arrow
- 4" color band

## ST-218 CURBSIDE - DIRECTIONAL - VEHICULAR



- Two directional, one level of messaging
- Used above a roadway lane at curbsides as users approach terminals from the roadways
- Used for primary information
- Non-illuminated
- Face size shown: 1'-6"H x 18'-0"L
- Applicable Sign Box Type: E-2
- 6" cap height
- 12" symbol
- 1'-4" arrow
- 12" color band

## ST-219 CURBSIDE - DIRECTIONAL - VEHICULAR

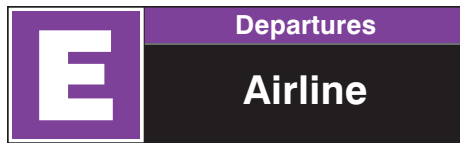

- One directional, one level of messaging
- Used above a roadway lane at curbsides as users approach the terminals from the roadways
- Non-illuminated
- Used for primary information
- Face size shown: 1'-6"H x 12'-0"L
- Applicable Sign Box Type: E-1
- 6" cap height
- 12" symbol
- 1'-4" arrow
- 12" color band

**Identification****ST-251 CURBSIDE - IDENTIFICATION**

- Terminal ID - Airline Listing
- Used at curbside at terminal entrances and perpendicular to vehicular travel
- Used for primary information
- Illuminated
- Face size shown: 2'-4"H x 8'-0"L
- Applicable Sign Box Type: D-251
- 5" header cap height
- 6" cap height
- 2'-4" symbol
- 7 1/2" header band
- 1/2" rule line

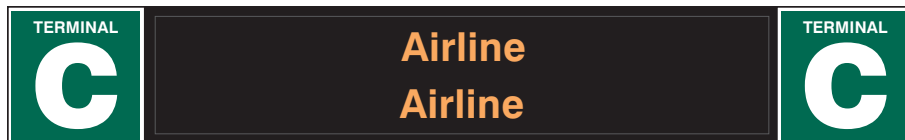
**ST-252 CURBSIDE - IDENTIFICATION**

- Terminal ID - Airline Listing
- Used at curbside over terminal door entrances
- Used for primary information
- Illuminated
- Variable Message System Display
- Face size shown: 2'-4"H x 15'-8"L
- Applicable Sign Box Type: D-252
- 6" VMS cap height
- 2'-4" symbol

ST-255 CURBSIDE - IDENTIFICATION

---



- Door ID
- Used at terminal entrance doors both interior and exterior
- Used for secondary information
- Non-illuminated
- Overall Size: 1'-0" Diameter
- Applicable Sign Box Type: Graphic Film with pressure-activated adhesive\*
- 2" primary cap height
- 1" secondary cap height

\* Screen print graphic onto 3M Controltac Plus Graphic Film Series 160 (or approved equal). Surface application. Apply sign to each side of door.

ST-256 CURBSIDE - AIRPORT SHUTTLE IDENTIFICATION



*Facing Pedestrians*



*Facing Ongoing Traffic*



*Facing Terminal*



*Facing Roadway*

- Ground Transportation ID
- Used at curbside to identify Ground Transportation functions
- Located perpendicular to vehicular traffic
- Used for secondary information
- Non-illuminated
- Face size shown: 3'-0"H x 3'-0"L
- Applicable Sign Box Type: H

***Facing Pedestrians & Facing Ongoing Traffic***

- 3" header cap height
- 9" header symbol
- 10" header band 2" cap height
- 3" symbol

***Facing Roadway***

- 4-1/2" header cap height
- 10" header band
- 3-3/4" cap height
- 9" symbol

ST-257 CURBSIDE - RENTAL CAR - BLUE LINE IDENTIFICATION

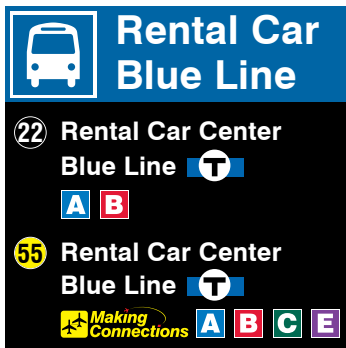

*Facing Pedestrians*

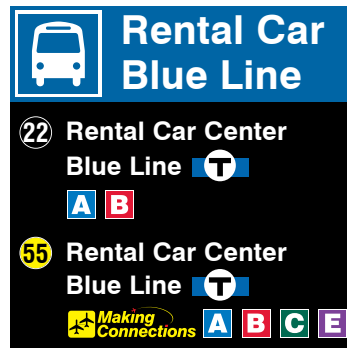

*Facing Ongoing Traffic*



*Facing Terminal*



*Facing Roadway*

- Ground Transportation ID
- Used at curbside to identify Ground Transportation functions
- Located perpendicular to vehicular traffic
- Used for secondary information
- Non-illuminated
- Face size shown: 3'-0"H x 3'-0"L
- Applicable Sign Box Type: H

***Facing Pedestrians & Facing Ongoing Traffic***

- 3" header cap height
- 9" header symbol
- 10" header band 2" cap height
- 3" symbol

***Facing Roadway***

- 4-1/2" header cap height
- 10" header band
- 3-3/4" cap height
- 9" symbol

## ST-258 CURBSIDE - TAXI IDENTIFICATION

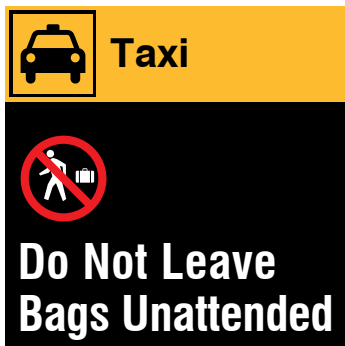
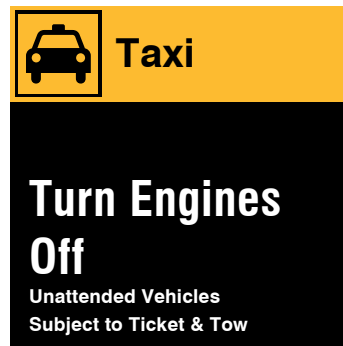
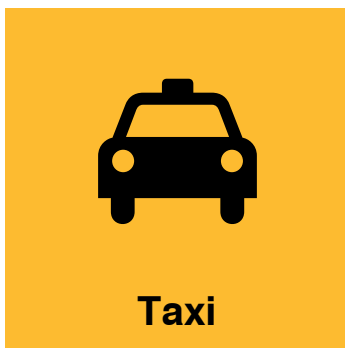
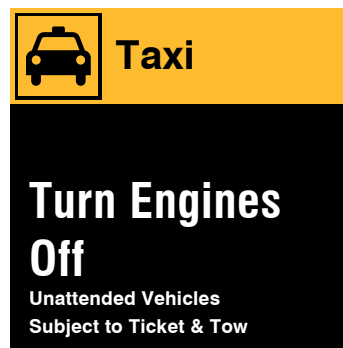
*Facing Pedestrians**Facing Ongoing Traffic**Facing Terminal**Facing Roadway*

- Ground Transportation ID
- Used at curbside to identify Ground Transportation functions
- Located perpendicular to vehicular traffic
- Used for secondary information
- Non-illuminated
- Face size shown: 3'-0"H x 3'-0"L
- Applicable Sign Box Type: H
  
- 3" header cap height
- 9" header symbol
- 10" header band
- 3-3/4" cap height
- 1-1/2" supporting text cap height
- 9" symbol

ST-259 CURBSIDE - LOGAN EXPRESS IDENTIFICATION

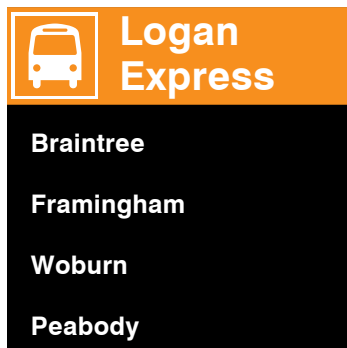

*Facing Pedestrians*

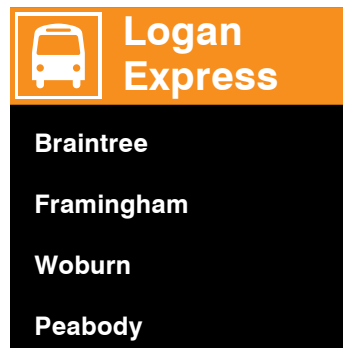

*Facing Ongoing Traffic*



*Facing Terminal*



*Facing Roadway*

- Ground Transportation ID
- Used at curbside to identify Ground Transportation functions
- Located perpendicular to vehicular traffic
- Used for secondary information
- Non-illuminated
- Face size shown: 3'-0"H x 3'-0"L
- Applicable Sign Box Type: H

***Facing Pedestrians & Facing Ongoing Traffic***

- 3" header cap height
- 9" header symbol
- 10" header band
- 2" cap height

***Facing Roadway***

- 4-1/2" header cap height
- 10" header band
- 3-3/4" cap height
- 9" symbol

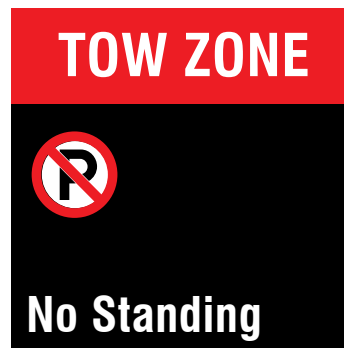

## ST-260 CURBSIDE - CHARTER BUS IDENTIFICATION

*Facing Pedestrians**Facing Ongoing Traffic**Facing Terminal**Facing Roadway*

- Ground Transportation ID
- Used at curbside to identify Ground Transportation functions
- Located perpendicular to vehicular traffic
- Used for secondary information
- Non-illuminated
- Face size shown: 3'-0"H x 3'-0"L
- Applicable Sign Box Type: H

***Facing Pedestrians & Facing Ongoing Traffic***

- 3" header cap height
- 9" header symbol
- 10" header band
- 3-3/4" cap height
- 9" symbol

***Facing Roadway***

- 4-1/2" header cap height
- 10" header band
- 3-3/4" cap height
- 9" symbol

ST-261 CURBSIDE - SHARED VAN IDENTIFICATION



*Facing Pedestrians*



*Facing Ongoing Traffic*



*Facing Terminal*

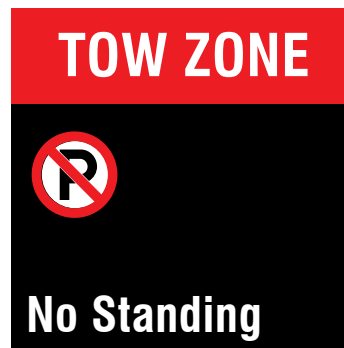

*Facing Roadway*

- Ground Transportation ID
- Used at curbside to identify Ground Transportation functions
- Located perpendicular to vehicular traffic
- Used for secondary information
- Non-illuminated
- Face size shown: 3'-0"H x 3'-0"L
- Applicable Sign Box Type: H

***Facing Pedestrians & Facing Ongoing Traffic***

- 3" header cap height
- 9" header symbol
- 10" header band
- 3-3/4" cap height
- 9" symbol

***Facing Roadway***

- 4-1/2" header cap height
- 10" header band
- 3-3/4" cap height
- 9" symbol

ST-262 CURBSIDE - COURTESY BUS IDENTIFICATION

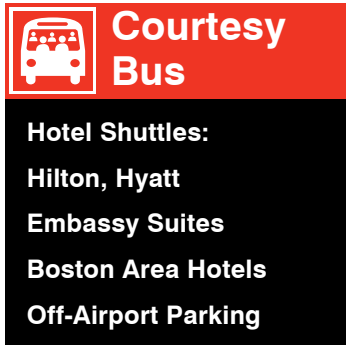

*Facing Pedestrians*

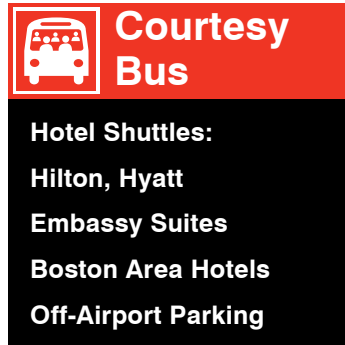

*Facing Ongoing Traffic*



*Facing Terminal*



*Facing Roadway*

- Ground Transportation ID
- Used at curbside to identify Ground Transportation functions
- Located perpendicular to vehicular traffic
- Used for secondary information
- Non-illuminated
- Face size shown: 3'-0"H x 3'-0"L
- Applicable Sign Box Type: H

***Facing Pedestrians & Facing Ongoing Traffic***

- 3" header cap height
- 9" header symbol
- 10" header band
- 2" cap height

***Facing Roadway***

- 4-1/2" header cap height
- 10" header band
- 3-3/4" cap height
- 9" symbol

## ST-263 CURBSIDE - LIMOS IDENTIFICATION

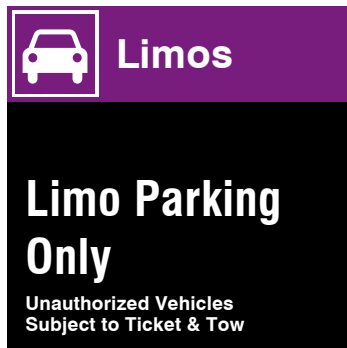
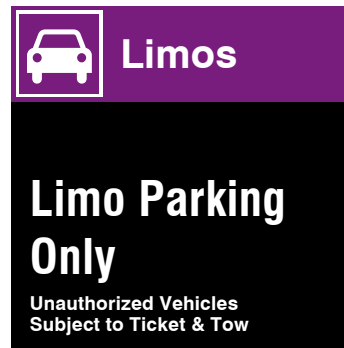
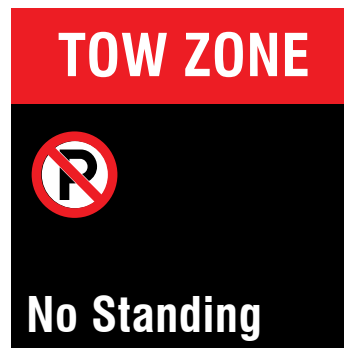
*Facing Pedestrians**Facing Ongoing Traffic**Facing Terminal**Facing Roadway*

- Ground Transportation ID
- Used at curbside to identify Ground Transportation functions
- Located perpendicular to vehicular traffic
- Used for secondary information
- Non-illuminated
- Face size shown: 3'-0"H x 3'-0"L
- Applicable Sign Box Type: H

***Facing Pedestrians & Facing Ongoing Traffic***

- 3" header cap height
- 9" header symbol
- 10" header band
- 3-3/4" cap height
- 1-1/2" supporting text cap height

***Facing Roadway***

- 4-1/2" header cap height
- 10" header band
- 3-3/4" cap height
- 9" symbol

## ST-264 CURBSIDE - PASSENGER PICKUP IDENTIFICATION

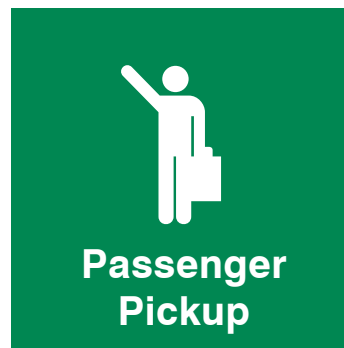
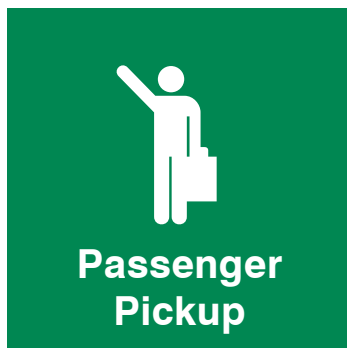
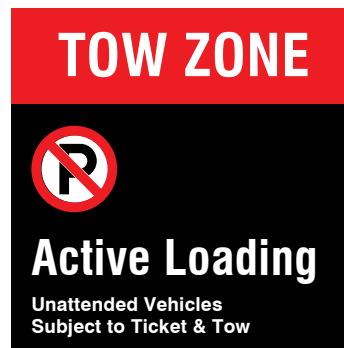
*Facing Pedestrians**Facing Ongoing Traffic**Facing Terminal**Facing Roadway*

- Ground Transportation ID
- Used at curbside to identify Ground Transportation functions
- Located perpendicular to vehicular traffic
- Used for secondary information
- Non-illuminated
- Face size shown: 3'-0"H x 3'-0"L
- Applicable Sign Box Type: H

***Facing Pedestrians***

- 3" header cap height
- 9" header symbol
- 10" header band
- 3-3/4" cap height
- 9" symbol

***Facing Roadway***

- 4-1/2" header cap height
- 10" header band
- 3-3/4" cap height
- 1-1/2" supporting text cap height
- 9" symbol

ST-265 CURBSIDE - SILVER LINE IDENTIFICATION



*Facing Pedestrians*



*Facing Ongoing Traffic*

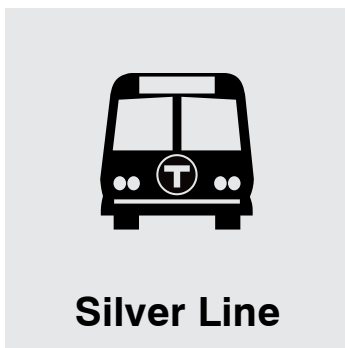

*Facing Terminal*



*Facing Roadway*

- Ground Transportation ID
- Used at curbside to identify Ground Transportation functions
- Located perpendicular to vehicular traffic
- Used for secondary information
- Non-illuminated
- Face size shown: 3'-0"H x 3'-0"L
- Applicable Sign Box Type: H

***Facing Pedestrians & Facing Ongoing Traffic***

- 3" header cap height
- 9" header symbol
- 3-1/4" T symbol
- 10" header band
- 2" cap height

***Facing Roadway***

- 4-1/2" header cap height
- 10" header band
- 3-3/4" cap height
- 9" symbol

ST-266 CURBSIDE - AIRPORT SHUTTLE IDENTIFICATION

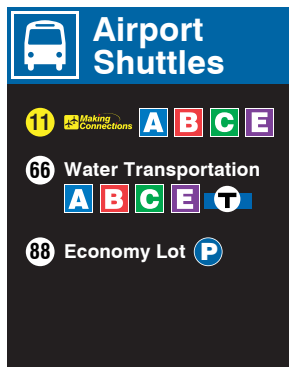

- Ground Transportation ID
- Used at curbside to identify Ground Transportation functions
- Located perpendicular to vehicular traffic
- Used for secondary information
- Non-illuminated
- Face size shown: 3'-2"H x 2'-6"L
- Applicable Sign Box Type: Flag
- 2-1/2" header cap height
- 9" header symbol
- 7" header band
- 1-1/2" cap height
- 3" symbol

ST-267 CURBSIDE - RENTAL CAR - BLUE LINE IDENTIFICATION



- Ground Transportation ID
- Used at curbside to identify Ground Transportation functions
- Located perpendicular to vehicular traffic
- Used for secondary information
- Non-illuminated
- Face size shown: 3'-2"H x 2'-6"L
- Applicable Sign Box Type: Flag
- 2-1/2" header cap height
- 9" header symbol
- 7" header band
- 1-1/2" cap height
- 3" symbol

ST-268 CURBSIDE - TAXI IDENTIFICATION

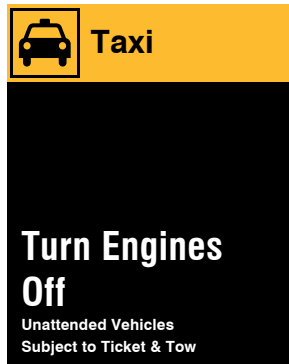

- Ground Transportation ID
- Used at curbside to identify Ground Transportation functions
- Located perpendicular to vehicular traffic
- Used for secondary information
- Non-illuminated
- Face size shown: 3'-2"H x 2'-6"L
- Applicable Sign Box Type: Flag
- 2-1/2" header cap height
- 9" header symbol
- 7" header band
- 3" cap height
- 1-1/4" supporting text cap height

ST-269 CURBSIDE - LOGAN EXPRESS IDENTIFICATION



- Ground Transportation ID
- Used at curbside to identify Ground Transportation functions
- Located perpendicular to vehicular traffic
- Used for secondary information
- Non-illuminated
- Face size shown: 3'-2"H x 2'-6"L
- Applicable Sign Box Type: Flag
- 2-1/2" header cap height
- 9" header symbol
- 7" header band
- 1-1/2" cap height



## ST-270 CURBSIDE - CHARTER BUS IDENTIFICATION



- Ground Transportation ID
- Used at curbside to identify Ground Transportation functions
- Located perpendicular to vehicular traffic
- Used for secondary information
- Non-illuminated
- Face size shown: 3'-2"H x 2'-6"L
- Applicable Sign Box Type: Flag
- 2-1/2" header cap height
- 9" header symbol
- 7" header band
- 3" cap height
- 7" symbol

## ST-271 CURBSIDE - SHARED VAN IDENTIFICATION

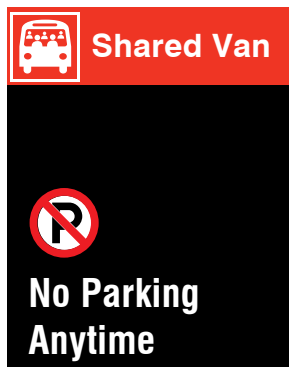

- Ground Transportation ID
- Used at curbside to identify Ground Transportation functions
- Located perpendicular to vehicular traffic
- Used for secondary information
- Non-illuminated
- Face size shown: 3'-2"H x 2'-6"L
- Applicable Sign Box Type: Flag
- 2-1/2" header cap height
- 9" header symbol
- 7" header band
- 3" cap height
- 7" symbol

ST-272 CURBSIDE - COURTESY BUS IDENTIFICATION

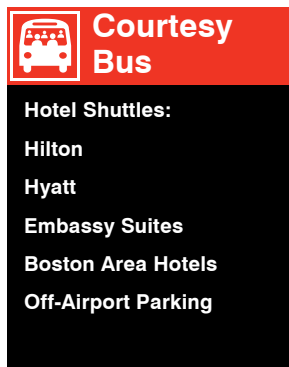

- Ground Transportation ID
- Used at curbside to identify Ground Transportation functions
- Located perpendicular to vehicular traffic
- Used for secondary information
- Non-illuminated
- Face size shown: 3'-2"H x 2'-6"L
- Applicable Sign Box Type: Flag
- 2-1/2" header cap height
- 9" header symbol
- 7" header band
- 1-1/2" cap height

ST-273 CURBSIDE - LIMOS IDENTIFICATION

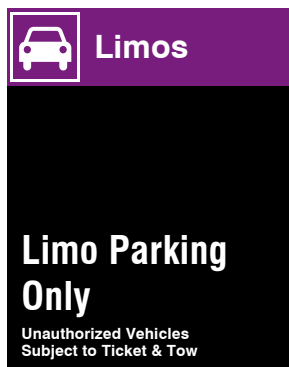

- Ground Transportation ID
- Used at curbside to identify Ground Transportation functions
- Located perpendicular to vehicular traffic
- Used for secondary information
- Non-illuminated
- Face size shown: 3'-2"H x 2'-6"L
- Applicable Sign Box Type: Flag
- 2-1/2" header cap height
- 9" header symbol
- 7" header band
- 3" cap height
- 1-1/4" supporting text cap height

ST-274 CURBSIDE - PASSENGER PICKUP IDENTIFICATION

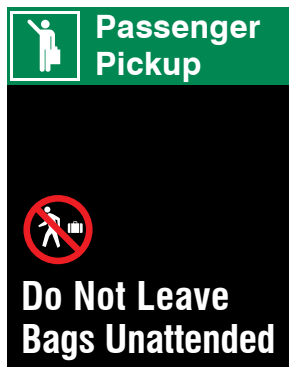

- Ground Transportation ID
- Used at curbside to identify Ground Transportation functions
- Located perpendicular to vehicular traffic
- Used for secondary information
- Non-illuminated
- Face size shown: 3'-2"H x 2'-6"L
- Applicable Sign Box Type: Flag
- 2-1/2" header cap height
- 9" header symbol
- 7" header band
- 3" cap height
- 7" symbol

ST-275 CURBSIDE - SILVER LINE IDENTIFICATION



- Ground Transportation ID
- Used at curbside to identify Ground Transportation functions
- Located perpendicular to vehicular traffic
- Used for secondary information
- Non-illuminated
- Face size shown: 3'-2"H x 2'-6"L
- Applicable Sign Box Type: Flag
- 2-1/2" header cap height
- 9" header symbol
- 2-1/2" T symbol
- 7" header band
- 1-1/2" cap height

**Informational**

**ST-281 CURBSIDE - INFORMATIONAL**

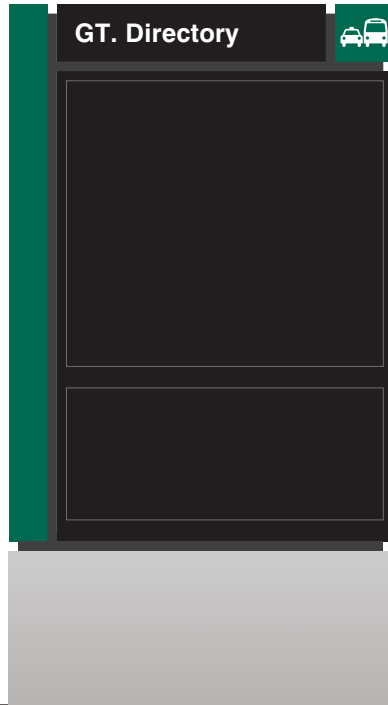

- Ground Transportation Directory
- Used at curbside for pedestrian use outside main circulation path
- Used for primary and secondary information
- Non-illuminated
- Interior artwork
- Overall Size: 6'-0"H x 3'-4"L x 1'-0"D
- Applicable Sign Box Type: S-281
- 2" header cap height
- 5" symbol
- 4" color band
- 6" header band

\* Sign face shown within context of sign box  
 Reveal shown as gray for illustrative purposes.  
 Color to be black.

**ST-282 CURBSIDE - INFORMATIONAL**



- Parking Regulatory
- Used at curbsides at both arrivals and departures levels
- Used for tertiary information
- Non-illuminated
- Size shown: 2'-0"H x 1'-6"L
- Applicable Sign Box Type: H
- 2 1/2" primary cap height
- 1 1/2" secondary cap height
- 6" symbol



ST-283 CURBSIDE - INFORMATIONAL



- Regulatory
- Used at curbsides at both arrivals and departures levels
- Used for tertiary information
- Non-illuminated
- Size shown: 2'-0"H x 1'-6"L
- Applicable Sign Box Type: H
- 2 1/2" primary cap height
- 1 1/2" secondary cap height
- 6" symbol

ST-284 CURBSIDE - INFORMATIONAL



- Pedestrian Caution
- Used at curbsides at both arrivals and departures levels
- Used for tertiary information
- Non-illuminated
- Size shown: 2'-0"H x 1'-6"L
- Applicable Sign Box Type: H
- 2 1/2" primary cap height
- 1 1/2" secondary cap height
- 6" symbol

ST-285 CURBSIDE - INFORMATIONAL

---

**Clearance 6'-8"**

- Vehicular Clearance ID
  - Used over the roadway as users approach curbsides to delineate height clearance for vehicular traffic
  - Used for tertiary information
  - Non-illuminated
  - Size shown: 1'-0"H x 12'-0"L
  - Applicable Sign Box Type: E-1
- 6" cap height
  - 2" stripe

### 5.3 PARKING

#### 300 SERIES

301 - 350	Directional
351 - 380	Identification
381 - 399	Informational

**Directional****ST-301 PARKING - DIRECTIONAL - VEHICULAR**

- One directional, one level of messaging
- Used in parking garages above vehicular traffic
- Used for primary information
- Non-illuminated or illuminated
- Size shown: 0'-9"H x 6'-0"L
- Applicable Sign Box Types: E-1, A-1, B-1, A-1-I, B-1-I

\* *Note: The message "EXIT" shall be retroreflective vinyl yellow.*

- 4" cap height
- 6" symbol
- 7" arrow
- 6" color band

**ST-302 PARKING - DIRECTIONAL - VEHICULAR**

- Two directional, one level of messaging
- Used in parking garages above vehicular traffic
- Used for primary information
- Non-illuminated or illuminated
- Size shown: 0'-9"H x 12'-0"L
- Applicable Sign Box Types: E-1, A-2, B-2, A-2-I, B-2-I

- 4" cap height
- 6" symbol
- 7" arrow
- 6" color band

**ST-303 PARKING - DIRECTIONAL - VEHICULAR**

- One directional, one level of messaging
- Used in parking garages above vehicular traffic
- Used for primary information
- Non-illuminated or illuminated
- Size shown: 0'-9"H x 12'-0"L
- Applicable Sign Box Types: E-1, A-2, B-2, A-2-I, B-2-I

\* *Note: The message "EXIT" shall be retroreflective vinyl yellow.*

- 4" cap height
- 6" symbol
- 7" arrow
- 6" color band



## ST-321 PARKING - DIRECTIONAL - PEDESTRIAN



- One directional, one level of messaging
  - Used in pedestrian walkways from garage to terminals and in elevator lobbies
  - Used for primary information
  - Non-illuminated or illuminated
  - Size shown: 0'-9"H x 6'-0"L
  - Applicable Sign Box Types: A-1, B-1, A-1-I, B-1-I
- 4" cap height
  - 6" symbol
  - 7" arrow
  - 6" color band

\* *Note: The pedestrian crosswalk symbol is only to be used to direct pedestrians to a crosswalk. It should be oriented to the direction of travel.*

## ST-322 PARKING - DIRECTIONAL - PEDESTRIAN



- Two directional, one level of messaging
  - Used in pedestrian walkways from garage to terminals and in elevator lobbies
  - Used for primary information
  - Non-illuminated or illuminated
  - Size shown: 0'-9"H x 12'-0"L
  - Applicable Sign Box Types: A-2, B-2, A-2-I, B-2-I
- 4" cap height
  - 6" symbol
  - 7" arrow
  - 6" color band

\* *Note: The pedestrian crosswalk symbol is only to be used to direct pedestrians to a crosswalk. It should be oriented to the direction of travel.*

## ST-323 PARKING - DIRECTIONAL - PEDESTRIAN



- One directional, one level of messaging
  - Used in pedestrian walkways from garage to terminals and in elevator lobbies
  - Used for primary information
  - Non-illuminated or illuminated
  - Size shown: 0'-9"H x 12'-0"L
  - Applicable Sign Box Types: A-2, B-2, A-2-I, B-2-I
- 4" cap height
  - 6" symbol
  - 7" arrow
  - 6" color band

\* *Note: The pedestrian crosswalk symbol is only to be used to direct pedestrians to a crosswalk. It should be oriented to the direction of travel.*

ST-327 PARKING - DIRECTIONAL - PEDESTRIAN



- One directional, two levels of messaging
- Used in pedestrian walkways from garage to terminals at roadways
- Used for primary information
- Non-illuminated or illuminated
- Size shown: 1'-9"H x 12'-0"L
- Applicable Sign Box Types: A-2, B-2, A-2-I, B-2-I
- 3" cap height
- 6" symbol
- 8" arrow
- 6" color band

ST-328 PARKING - DIRECTIONAL - PEDESTRIAN



- One directional, three levels of messaging
- Used in pedestrian walkways from garage to terminals and in elevator lobbies
- Used for primary information
- Non-illuminated or illuminated
- Size shown: 1'-9"H x 12'-0"L
- Applicable Sign Box Types: A-2, B-2, A-2-I, B-2-I
- 3" cap height
- 6" symbol
- 8" arrow
- 6" color band

ST-351 PARKING - IDENTIFICATION - VEHICULAR



- Aisle ID Panels
- Used on columns to designate an aisle
- Non-illuminated
- Massport artwork
- Size shown: 2'-6"H x 3'-0"L
- Applicable Sign Box Type: G-3

**Identification**

**ST-355 PARKING - IDENTIFICATION - PEDESTRIAN**



- Level ID
- Used overhead and above doorways to denote level identification
- Used for primary information
- Non-illuminated or illuminated
- Size shown: 1'-0"H x 7'-6"L
- Applicable Sign Box Types: B-2, B-2-I
- 5" cap height
- 3" color band

**ST-365 PARKING - IDENTIFICATION - PEDESTRIAN**



- Terminal ID
- Used in parking garages
- Used for primary information
- Internally Illuminated
- Overall Size: 8'-0"H x 4'-0"L
- Applicable Sign Box Type: S-365
- 6" cap height
- 2'-6" symbol

\* *Sign face shown within context of sign box  
Reveal shown as gray for illustrative purposes. Color to be black.*

ST-366 PARKING - IDENTIFICATION - PEDESTRIAN

---



- Level ID Pylon
- Used at pedestrian islands
- Used for primary information
- Non-illuminated
- Overall Size: 6'-6"H x 4'-0"L
- Applicable Sign Box Type: S-366
- 5" cap height
- 10" symbol

\* *Sign face shown within context of sign box  
Reveal shown as gray for illustrative purposes. Color to be black.*

ST-370 PARKING - IDENTIFICATION - PEDESTRIAN

---



- Terminal Icon
- Used on facade above roof canopy
- Used for primary information
- Internally Illuminated
- Overall Size: 7'-7"H x 6'-8"L
- Applicable Sign Box Type: S-370
- 6" cap height
- 2'-6" symbol

ST-371 PARKING - IDENTIFICATION - PEDESTRIAN

---



- Lobby Floor ID Panels
- Used in terminal lobbies
- Non-illuminated
- Massport artwork
- Size shown: 4'-8"H x 3'-6"L
- Applicable Sign Box Type: G-3

ST-372 PARKING - IDENTIFICATION - PEDESTRIAN

---



- Lobby Floor ID Panels
- Used in terminal lobbies
- Non-illuminated
- Massport artwork
- Size shown: 1'-6"H x 1'-2"L
- Applicable Sign Box Type: G-3

ST-375 PARKING - IDENTIFICATION - PEDESTRIAN



- Elevator ID
- Used at pedestrian lobby elevator banks
- Non-illuminated
- Size shown: 1'-0"H x 1'-0"L
- Applicable Sign Box Type: F-1

ST-381 PARKING - INFORMATIONAL - VEHICULAR



- Parking regulatory
- Used in parking garages
- Non-illuminated
- Size shown: 2'-0"H x 1'-6"L
- Applicable Sign Box Type: Fasten sign face panel directly to surface, or post mount
- 2 1/2" primary cap height
- 1 1/2" secondary cap height
- 6" symbol

## Informational

### ST-383 PARKING - INFORMATIONAL - VEHICULAR



- Vehicular clearance ID
- Used to delineate height clearance for vehicular traffic
- Non-illuminated
- Size shown: 1'-0"H x 12'-0"L
- Applicable Sign Box Type: E-1
- 6" cap height
- 2" stripe

### ST-391 PARKING - INFORMATIONAL - PEDESTRIAN



- Pedestrian regulatory
- Used in parking garages
- Non-illuminated
- Applicable Sign Box Types: Fasten sign face panel directly to surface, or post mount
- 2 1/2" primary cap height
- 1 1/2" secondary cap height
- 6" symbol

### ST-392 PARKING - INFORMATIONAL - PEDESTRIAN



- General regulatory
- Used in parking garages
- Non-illuminated
- Applicable Sign Box Types: Fasten sign face panel directly to surface, or post mount
- 2 1/2" primary cap height
- 1 1/2" secondary cap height
- 6" symbol

ST-393 PARKING - INFORMATIONAL - PEDESTRIAN

---



- Garage directory panels
- Used in parking garages
- Non-illuminated
- Massport artwork
- Size shown: 4'-8"H x 3'-6"L
- Applicable Sign Box Type: Fasten sign face panel directly to surface

ST-394 PARKING - INFORMATIONAL - PEDESTRIAN

---



- Elevator button directory
- Used inside elevator cabs above call buttons
- Non-illuminated
- Massport artwork
- Size shown: 1'-0"H x 0'-9"L
- Applicable Sign Box Type: Fasten sign face panel directly to surface



**5.4 ROADWAY**

**400 SERIES**

401 - 450	Directional
451 - 480	Identification
481 - 499	Informational

Directional

ST-401 ROADWAYS - DIRECTIONAL

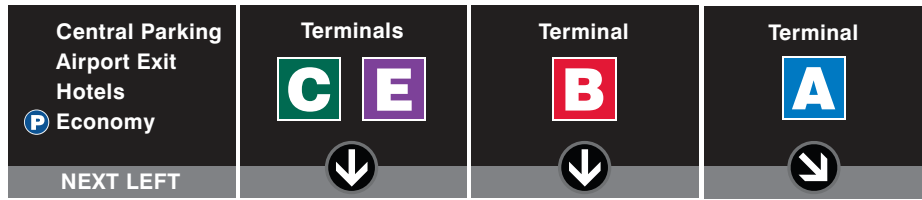

Arrivals Level Inbound

- Four-direction overhead directional
- Used on roadways perpendicular to traffic
- Used for primary and secondary information
- Externally Illuminated
- Size shown: 10'-0"H x 48'-0"L
- Applicable Sign Box Type: R-1
- 10" cap height
- 3'-4" primary symbol
- 1'-8" secondary symbol
- 2'-0" arrow
- 1'-8" color band
- 2'-6" arrow circle

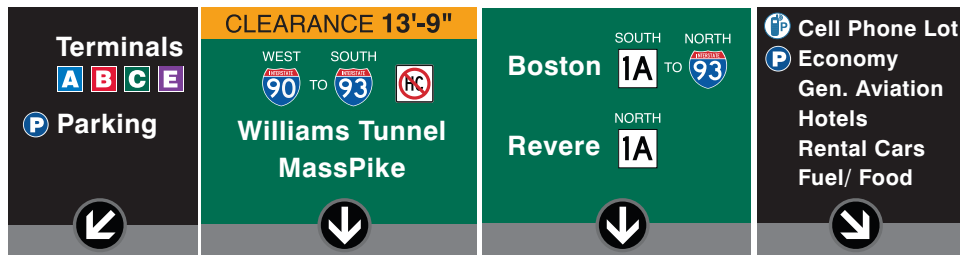

Departures Level Inbound

- Four-direction overhead directional
- Used on roadways perpendicular to traffic
- Used for primary and secondary information
- Externally Illuminated
- Size shown: 13'-0"H x 50'-0"L
- Applicable Sign Box Type: R-1
- 12" primary cap height
- 10" secondary cap height
- 1'-8" symbol
- 2'-0" arrow
- 1'-8" color band
- 2'-6" arrow circle

ST-402 ROADWAYS - DIRECTIONAL

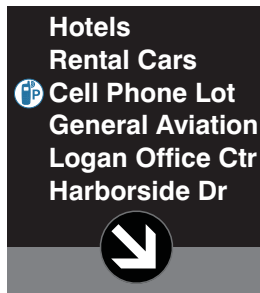

**Entering Airport from Rte 90 E**

- One direction overhead directional
- Used on roadways perpendicular to traffic
- Used for primary and secondary information
- Externally Illuminated
- Size shown: 10'-0"H x 9'-0"L
- Applicable Sign Box Type: R-2
- 8" cap height
- 1'-8" symbol
- 2'-0" arrow
- 1'-8" color band
- 2'-6" arrow circle

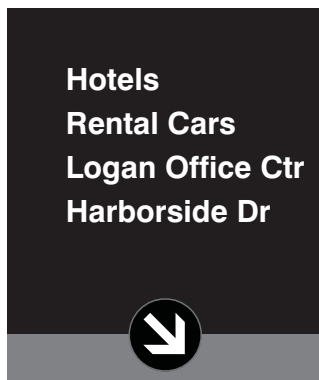

**Entering Airport from Rte 1A**

- One direction overhead directional
- Used on roadways perpendicular to traffic
- Used for primary and secondary information
- Externally Illuminated
- Size shown: 13'-0"H x 11'-0"L
- Applicable Sign Box Type: R-2
- 9" cap height
- 1'-8" symbol
- 2'-0" arrow
- 1'-8" color band
- 2'-6" arrow circle

ST-403 ROADWAYS - DIRECTIONAL

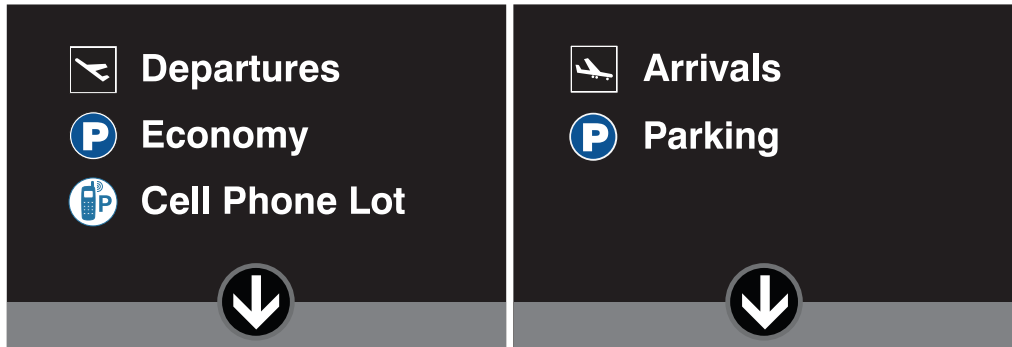

**Entering Airport from Rte 90 E**

- Two direction overhead directional
- Used on roadways perpendicular to traffic
- Used for primary information
- Externally Illuminated
- Size shown: 12'-0"H x 35'-0"L
- Applicable Sign Box Type: R-1
- 12" cap height
- 1'-8" symbol
- 2'-0" arrow
- 1'-8" color band
- 2'-6" arrow circle

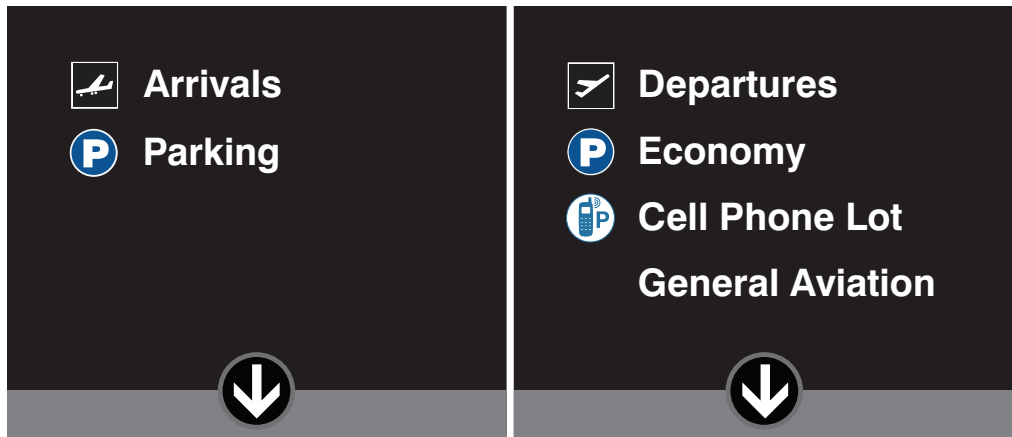

**Entering Airport from Rte 1A**

- Two direction overhead directional
- Used on roadways perpendicular to traffic
- Used for primary information
- Externally Illuminated
- Size shown: 15'-0"H x 35'-0"L
- Applicable Sign Box Type: R-1
- 12" cap height
- 1'-8" symbol
- 2'-0" arrow
- 1'-8" color band
- 2'-6" arrow circle

## ST-420 ROADWAYS - DIRECTIONAL

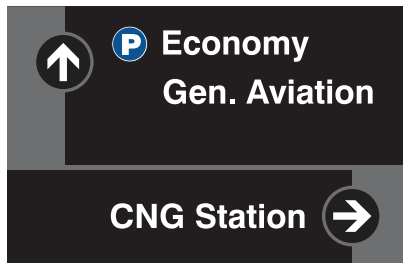

- Two direction roadside directional
- Used on roadways perpendicular to traffic
- Used for primary and secondary information
- Non-illuminated
- Size shown: 4'-6"H x 7'-0"L
- Applicable Sign Box Type: R-3
- 6" cap height
- 8" symbol
- 8" arrow
- 1'-0" color band
- 1'-0" arrow circle

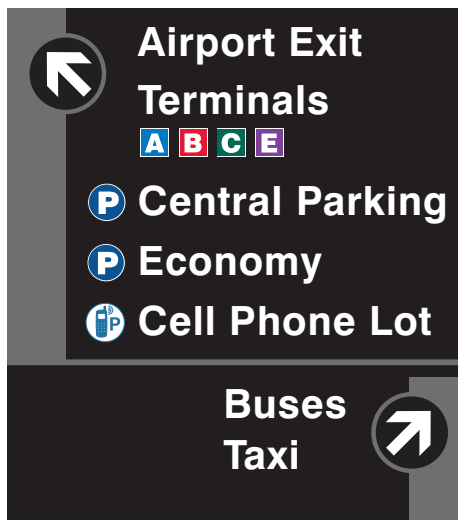

- Two direction roadside directional
- Used on roadways perpendicular to traffic
- Used for primary and secondary information
- Non-illuminated
- Size shown: 9'-0"H x 8'-0"L
- Applicable Sign Box Type: R-3
- 6" cap height
- 8" symbol
- 1'-0" arrow
- 1'-0" color band
- 1'-4" arrow circle

ST-421 ROADWAYS - DIRECTIONAL

---



- Return to Airport - Follow Signs
- Used on roadways perpendicular to traffic
- Non-illuminated
- Size shown: 5'-6"H x 3'-6"L
- Applicable Sign Box Type: post mount
- MUTCD standards
- FHWA Standard Alphabet Series B
- 6" cap height
- 2'-1" symbol
- 3" radius
- 3/4" border

ST-422 ROADWAYS - DIRECTIONAL

---



- Return to Airport - Keep Left / Right
- Used on roadways perpendicular to traffic
- Non-illuminated
- Size shown: 5'-6"H x 3'-6"L
- Applicable Sign Box Type: post mount

- MUTCD standards
- FHWA Standard Alphabet Series B
- 6" cap height
- 2'-1" symbol (rotated 45°)
- 3" radius
- 3/4" border

ST-423 ROADWAYS - DIRECTIONAL



- Return to Airport - Next Right / Left
- Used on roadways perpendicular to traffic
- Non-illuminated
- Size shown: 5'-6"H x 3'-6"L
- Applicable Sign Box Type: post mount

- MUTCD standards
- FHWA Standard Alphabet Series B
- 6" cap height
- 2'-1" symbol (rotated 45°)
- 3" radius
- 3/4" border



ST-424 ROADWAYS - DIRECTIONAL



- Return to Airport - Left / Right Arrow
- Used on roadways perpendicular to traffic
- Non-illuminated
- Size shown: 6'-0"H x 3'-6"L
- Applicable Sign Box Type: post mount

- MUTCD standards
- FHWA Standard Alphabet Series B
- 6" cap height
- 2'-1" symbol
- 1'-1 1/2" arrow
- 3" radius
- 3/4" border

ST-425 ROADWAYS - DIRECTIONAL



- Return to Airport - Straight Ahead on Left / Right Arrow
- Used on roadways perpendicular to traffic
- Non-illuminated
- Size shown: 6'-0"H x 3'-6"L
- Applicable Sign Box Type: post mount
- MUTCD standards
- FHWA Standard Alphabet Series B
- 6" cap height
- 2'-1" symbol (rotated 45°)
- 1'-1 1/2" arrow (rotated 45°)
- 3" radius
- 3/4" border

## Identification

### ST-451 ROADWAYS - IDENTIFICATION



#### Inbound Rt 1

- Overhead terminal identification
- Used on roadways perpendicular to traffic
- Used for primary information
- Externally Illuminated
- Size shown: 13'-0"H x 29'-0"L
- Applicable Sign Box Type: R-1
- 12" primary cap height
- 10" secondary cap height
- 3'-4" symbol
- 1'-8" color band

### ST-452 ROADWAYS - IDENTIFICATION



\* Sign face shown within context of sign box  
Reveal shown as gray for illustrative purposes. Color to be black

- Roadside and Curbside airline listings
- Used on curbside entrance perpendicular to vehicular traffic
- Used for secondary information
- Illuminated
- Size shown: 15'-0"H x 8'-0"L
- Applicable Sign Box Type: S-452
- 8" cap height
- 6" VMS cap height
- 2'-0" terminal symbol

**Informational**

ST-481 ROADWAYS - INFORMATIONAL

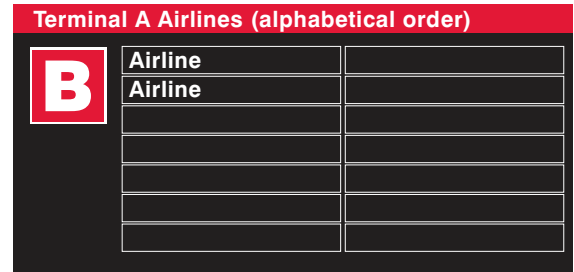
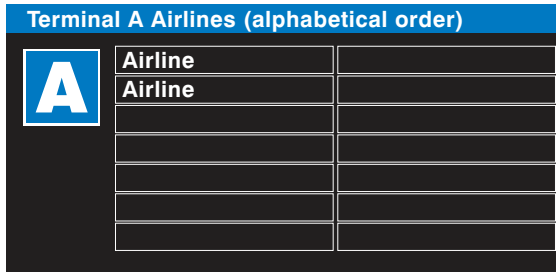

**Inbound Rt 1**

- Overhead airline information
- Used on roadways perpendicular to traffic
- Used for primary information
- Externally illuminated
- Size shown: 14'-0"H x 29'-0"L
- Changeable panel size: 1'-5"H x 11'-6"L
- Applicable Sign Box Type: R-1
- 10" cap height
- 4'-0" symbol
- 1'-6" color band

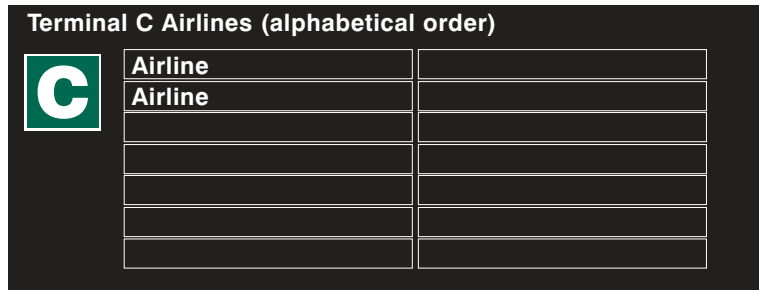

- Size shown: 14'-0"H x 37'-0"L
- Changeable panel size: 1'-5"H x 14'-0"L
- Applicable Sign Box Type: R-1

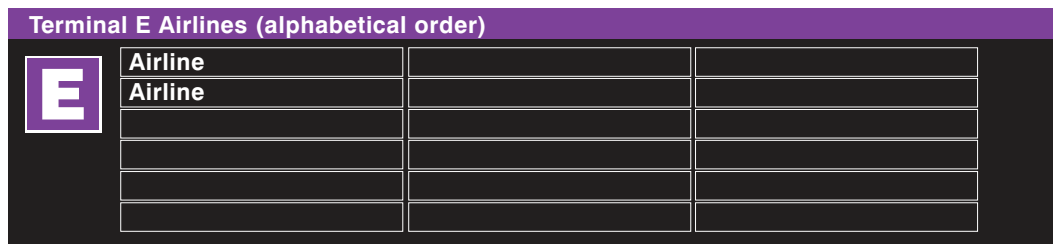

- Size shown: 12'-0"H x 52'-0"L
- Changeable panel size: 1'-5"H x 14'-0"L
- Applicable Sign Box Type: R-1



ST-482 ROADWAYS - INFORMATIONAL

---



- Pedestrian Traffic
- Used at crosswalks at curbsides
- Non-illuminated
- Size shown: 2'-0" diamond; 1'-0" H x 2'-0" L arrow plaque
- Applicable Sign Box Type: Post mount
- MUTCD standard layout
- 22" high symbol
- 8" long arrow

## 5.5 AIRPORT SERVICE BUILDINGS

### 500 SERIES

501 - 550	Directional
551 - 580	Identification
581 - 599	Informational

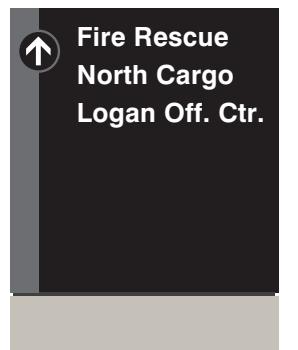
**Directional****ST-501 SERVICE BUILDINGS - DIRECTIONAL**

*\* Sign face shown within context of sign box.*

*Reveal at base shown as gray for illustrative purposes. Color to be black.*

- Vehicular Directional - Roadside
  - 1 and 2 directions
  - Used on support roads perpendicular to traffic to direct users to and from the Airport Services Buildings
  - Located roadside
  - Used for primary information
  - Non-illuminated
  - Overall Size: 6'-0"H x 4'-8"L
  - Applicable Sign Box Types: S-501
- 4" cap height
  - 8" arrow
  - 6" color band
  - 3/4" rule line

## Identification

### ST-551 SERVICE BUILDINGS - IDENTIFICATION



\* Sign face shown within context of sign box  
Reveals shown gray for illustrative purposes. Color to be black.

- Vehicular Building Identification - Roadside
- Used to identify all Airport Services Buildings
- Used on both Cargo and Non-Cargo Buildings
- Located roadside
- Used for primary information
- Non-illuminated
- Overall Size: 6'-0"H x 4'-8"L
- 1'-3" building number
- 4" cap height
- 1'-0" base
- 3/4" reveal

### ST-553 SERVICE BUILDINGS - IDENTIFICATION

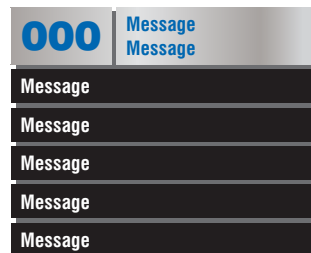

Reveals shown gray for illustrative purposes. Color to be black.

- Pedestrian Entry Door Building Identification
- Used to list departments and offices in building
- Information includes building number, building name, and department names
- Not used on cargo buildings
- Located at building facade at entrance door
- Used for secondary information
- Non-illuminated
- Brushed Stainless Steel Finish on Color Band
- Overall Size: 2'-2"H x 2'-8"W
- Typical Panel Size: 0'-3 1/2"H x 2'-8"W
- Applicable Sign Box Types: G-1
- 3" building number cap height
- 1 1/2" cap height
- 6" header band
- 1/2" reveals



## ST-561 SERVICE BUILDING - IDENTIFICATION - CARGO BUILDINGS

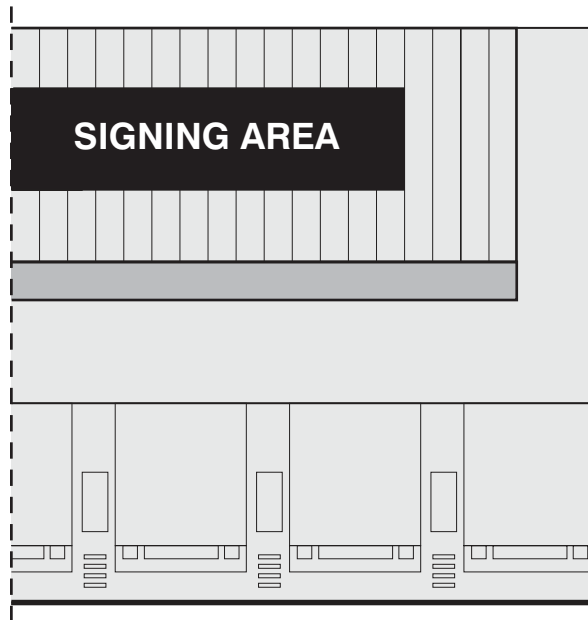

- Tenant ID (facade)
- Signing Area for Corporate Identification
- Used to identify cargo buildings at a vehicular scale
- Located at building facade
- Used for secondary information
- Overall Signing Area Dimensions: varies, see Section 7.1

ST-562 SERVICE BUILDING - IDENTIFICATION - CARGO BUILDINGS

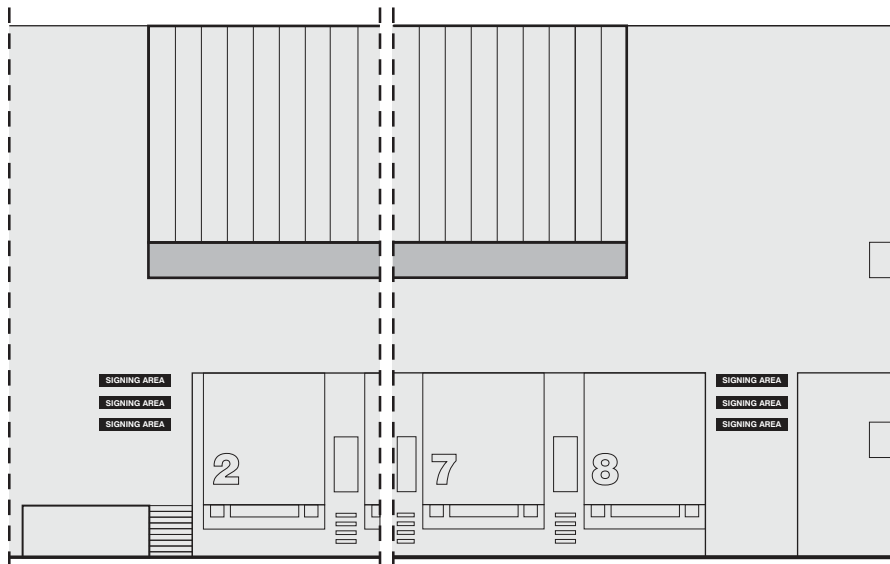

- Tenant ID (Entry Door)
- Signing Area for Corporate Identification
- Used to identify Cargo Buildings at a pedestrian scale
- Located at building facade at entrances
- Used for secondary information
- Overall Signing Area Dimensions: varies, see Section 7.1

ST-563 SERVICE BUILDING - IDENTIFICATION - CARGO BUILDINGS

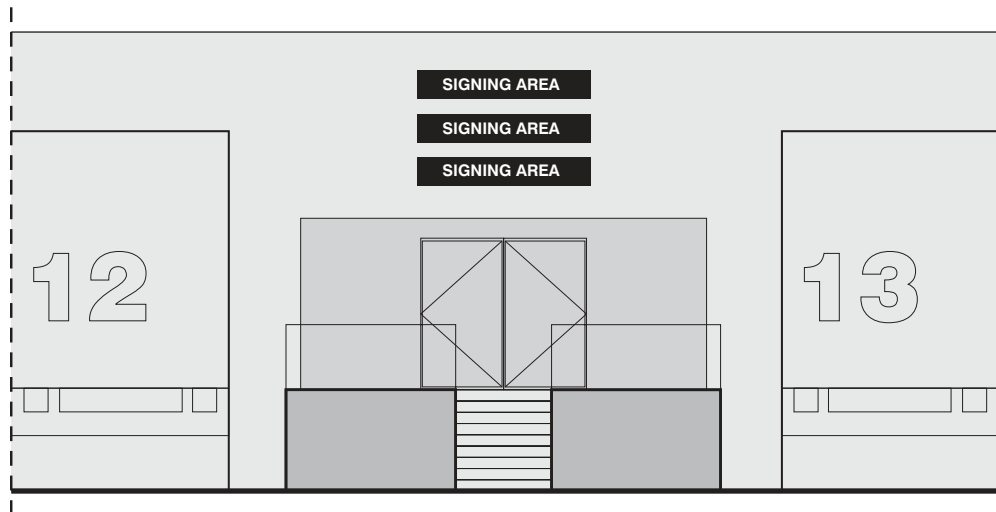

- Tenant ID (Entry Door)
- Signing Area for Corporate Identification
- Used to identify Cargo Buildings at a pedestrian scale
- Located at building facade at entrances
- Used for secondary information
- Overall Signing Area Dimensions: varies, see Section 7.1

5.6 FIRE AND LIFE SAFETY

600 SERIES

This section represents fire and life safety signage as used at Massport’s properties. Review of planned implementation is required by Fire Rescue and Aviation Security.

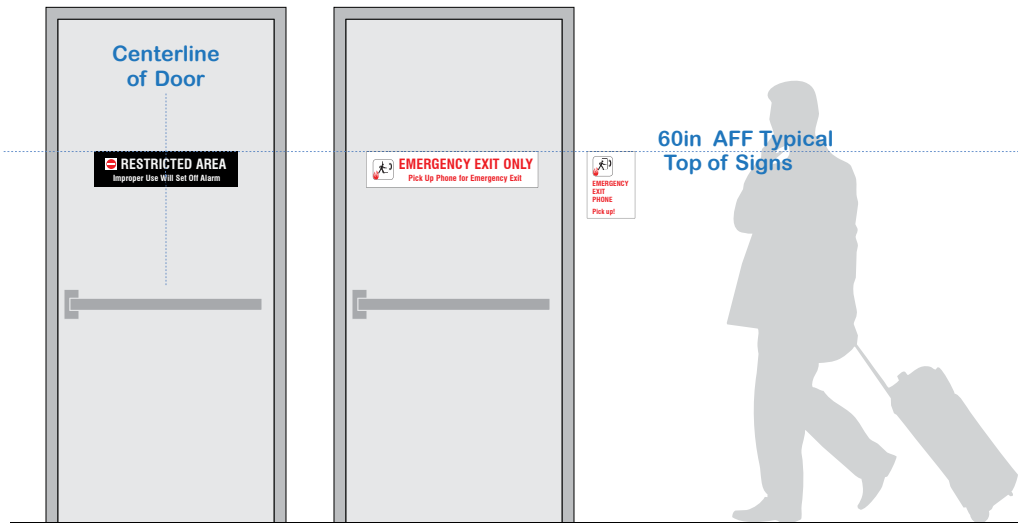

Typical Door Mountings

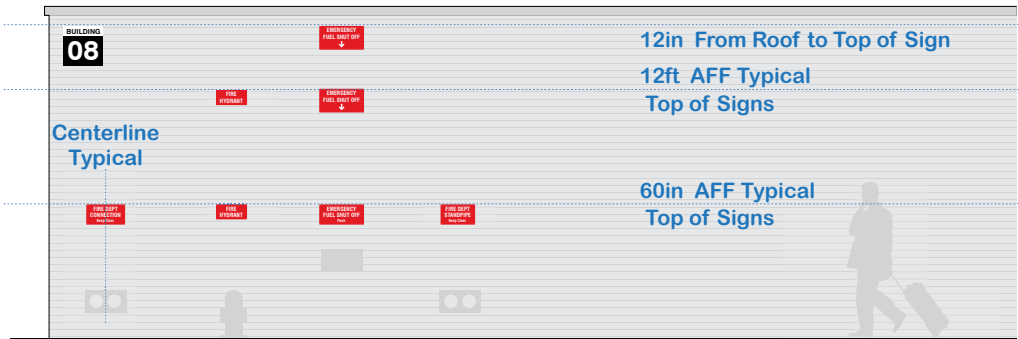

Typical Building Mountings

**Fire and Life Safety Signs****ST-601, Used at remotely controlled egress doors**

- .063 aluminum panel with 1/4" rounded edges, powder coated matte red (RAL 3000).
- Swiss 721 Cn BT matte white vinyl letters (3M 7725-20).
- Mechanically fasten to wall 60" above floor measured to top of sign.
- Four 1/8" diameter mounting holes located 3/8" from edge.

**ST-602, Used adjacent to fire rescue phones**

- .063 aluminum panel with 1/4" rounded edges, powder coated matte red (RAL 3000).
- Swiss 721 Cn BT matte white vinyl letters (3M 7725-20).
- Mechanically fasten to wall 60" above floor measured to top of sign.
- Four 1/8" diameter mounting holes located 3/8" from edge.

## ST-603, Used on alarmed egress doors



- .063 aluminum panel with 1/4" rounded edges, powder coated red (RAL 3000C).
- Swiss 721 Cn BT white vinyl letters.
- Mechanically fasten to center of door 60" above floor measured to top of sign.
- Four 1/8" diameter mounting holes located 3/8" from edge.

## ST-604, Used on alarmed egress doors within public areas of terminals

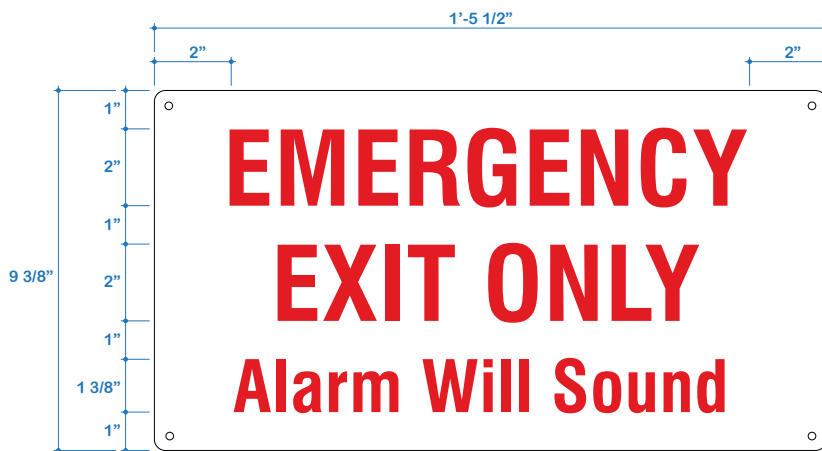

- .063 aluminum panel with 1/4" rounded edges, powder coated matte white (RAL 9003).
- Swiss 721 Cn BT red vinyl letters (3M 7125-13).
- Mechanically fasten to center of door 60" above floor measured to top of sign.
- Four 1/8" diameter mounting holes located 3/8" from edge.

## ST-605, Used on interior doors at fire separations



- .063 aluminum panel with 1/4" rounded edges, powder coated red (RAL 3000C).
- Swiss 721 Cn BT white vinyl letters.
- Mechanically fasten to center of door 60" above floor measured to top of sign.
- Four 1/8" diameter mounting holes located 3/8" from edge.

## ST-606, Used on doors at fire separations within public areas of terminals



- .063 aluminum panel with 1/4" rounded edges, powder coated matte white (RAL 9003).
- Swiss 721 Cn BT red vinyl letters (3M 7125-13).
- Mechanically fasten to center of door 60" above floor measured to top of sign.
- Four 1/8" diameter mounting holes located 3/8" from edge.

## ST-607, Used on exterior egress doors



- .063 aluminum panel with 1/4" rounded edges, powder coated red (RAL 3000C).
- Swiss 721 Cn BT white vinyl letters.
- Mechanically fasten to center of door 60" above floor measured to top of sign.
- Four 1/8" diameter mounting holes located 3/8" from edge.

## ST-608, Used on exterior egress doors within public areas of terminals



- .063 aluminum panel with 1/4" rounded edges, powder coated matte white (RAL 9003).
- Swiss 721 Cn BT red vinyl letters (3M 7125-13).
- Mechanically fasten to center of door 60" above floor measured to top of sign.
- Four 1/8" diameter mounting holes located 3/8" from edge.



## ST-609, Used above fire extinguishers

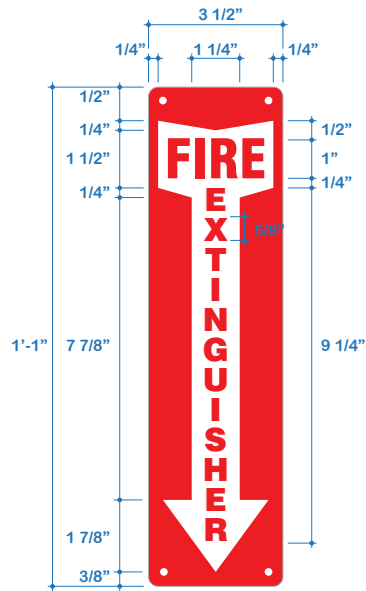

- .063 aluminum panel with 1/4" rounded edges, powder coated red (RAL 3000C).
- Swiss 721 Cn BT white vinyl letters.
- Mechanically fasten to wall 60" above floor measured to top of sign.
- Four 1/8" diameter mounting holes located 3/8" from edge.

## ST-610, Used above fire extinguishers

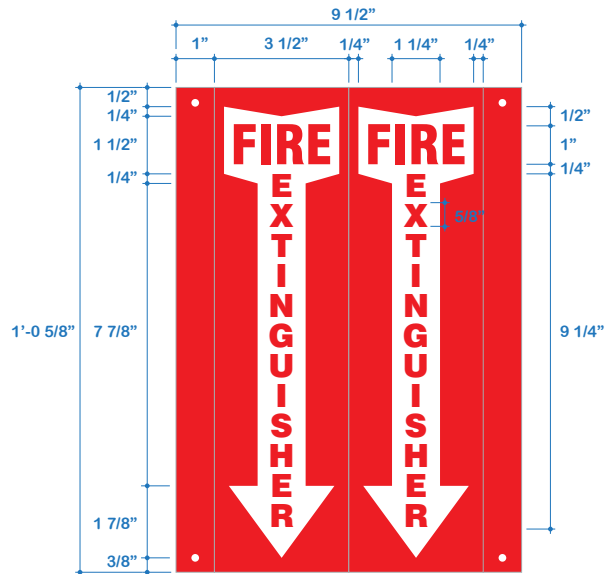

- .063 aluminum panel with 1/4" rounded edges, powder coated red (RAL 3000C).
- Swiss 721 Cn BT white vinyl letters.
- Bend to triangular plan profile.
- Mechanically fasten to wall.
- Four 1/8" diameter mounting holes located 3/8" from edge.

## ST-611, Used above Fire Hose Valve



- .063 aluminum panel with 1/4" rounded edges, powder coated red (RAL 3000C).
- Swiss 721 Cn BT white vinyl letters.
- Mechanically fasten to wall 60" above floor measured to top of sign.
- Four 1/8" diameter mounting holes located 3/8" from edge.

## ST-612, Used above Fire Hose Valve at Parking Garages



- .063 aluminum panel with 1/4" rounded edges, powder coated matte white (RAL 9003).
- Swiss 721 Cn BT red retroreflective vinyl letters (3M 5100R-72).
- Mechanically fasten to wall 60" above floor measured to top of sign.
- Four 1/8" diameter mounting holes located 3/8" from edge.

## ST-613, Used at door to Sprinkler Valve Rooms



- .063 aluminum panel with 1/4" rounded edges, powder coated red (RAL 3000C).
- Swiss 721 Cn BT white vinyl letters.
- Mechanically fasten to center of door 60" above floor measured to top of sign.
- Four 1/8" diameter mounting holes located 3/8" from edge.

## ST-614, Used above Standpipe



- .063 aluminum panel with 1/4" rounded edges, powder coated red (RAL 3000C).
- Swiss 721 Cn BT white vinyl letters.
- Mechanically fasten to wall 60" above floor measured to top of sign.
- Four 1/8" diameter mounting holes located 3/8" from edge.

## ST-615, Used above Fire Department Connections



- .063 aluminum panel with 1/4" rounded edges, powder coated red (RAL 3000C).
- Swiss 721 Cn BT white vinyl letters.
- Mechanically fasten to wall 60" above floor measured to top of sign.
- Four 1/8" diameter mounting holes located 3/8" from edge.

## ST-616, Used above Fire Department Connections



- .063 aluminum panel with 1/4" rounded edges, powder coated red (RAL 3000C).
- Swiss 721 Cn BT white vinyl letters.
- Mechanically fasten to wall 60" above floor measured to top of sign.
- Four 1/8" diameter mounting holes located 3/8" from edge.

ST-617, Used on nearest wall behind Fire Hydrant



- .063 aluminum panel with 1/4" rounded edges, powder coated red (RAL 3000C).
- Swiss 721 Cn BT white vinyl letters.
- Mechanically fasten to wall 60" above floor measured to top of sign.
- Four 1/8" diameter mounting holes located 3/8" from edge.

ST-618, Used in rooms with storage



- .063 aluminum panel with 1/4" rounded edges, powder coated red (RAL 3000C).
- Swiss 721 Cn BT white vinyl letters.
- Mechanically fasten to wall 1'-5 3/4" from ceiling measured to top of sign.
- Four 1/8" diameter mounting holes located 3/8" from edge.

## ST-619, Used at fuel shut off located at low-range viewing distance



- .063 aluminum panel with 1/4" rounded edges, powder coated red (RAL 3000C).
- Swiss 721 Cn BT white vinyl letters.
- Mechanically fasten to wall 60" above floor measured to top of sign.
- Four 1/8" diameter mounting holes located 3/8" from edge.

## ST-620, Used at fuel shut off located at mid-range viewing distance

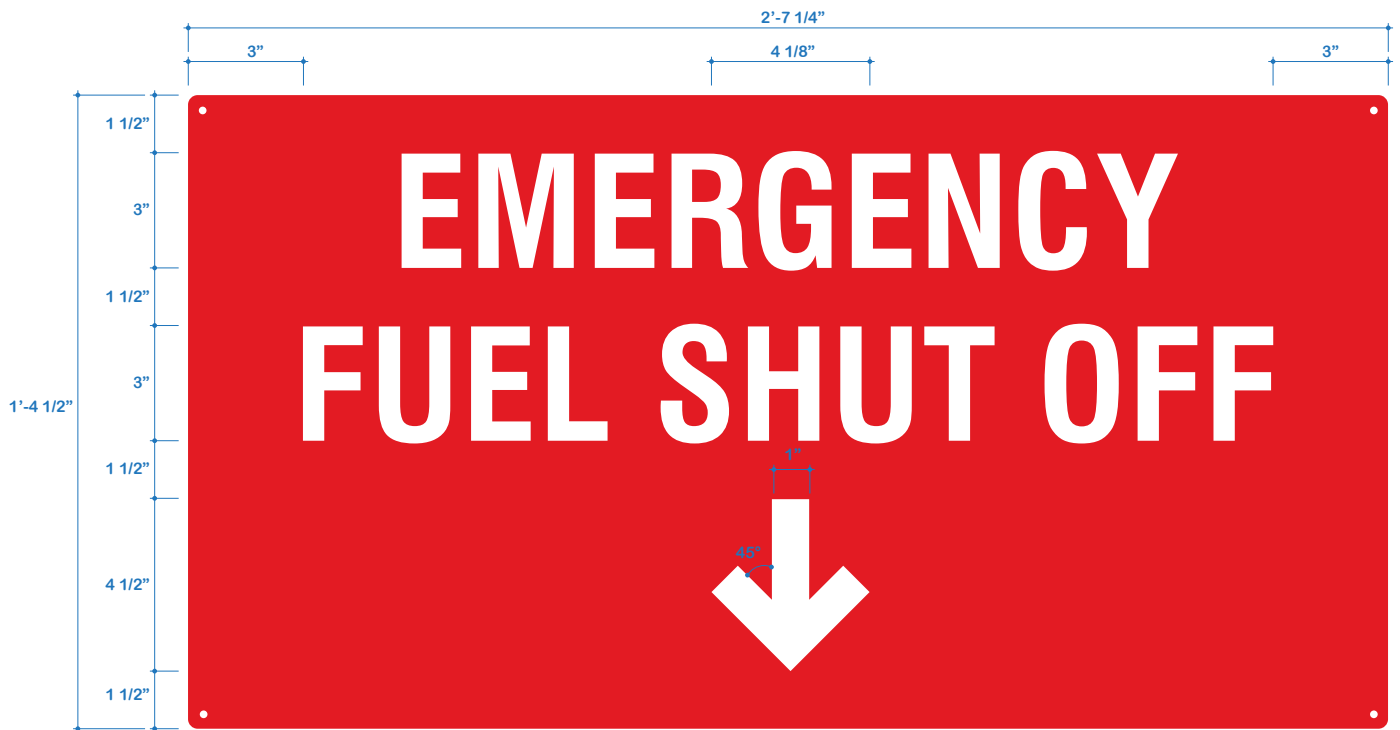

- .063 aluminum panel with 1/4" rounded edges, powder coated red (RAL 3000C).
- Swiss 721 Cn BT white vinyl letters.
- Mechanically fasten to wall 144" above floor measured to top of sign.
- Four 1/8" diameter mounting holes located 3/8" from edge.



## ST-621, Used at fuel shut off located at high-range viewing distance



- .063 aluminum panel with 1/4" rounded edges, powder coated red (RAL 3000C).
- Swiss 721 Cn BT white vinyl letters.
- Mechanically fasten to exterior wall 12" from roof measured to top of sign.
- Four 1/8" diameter mounting holes located 3/8" from edge.

## ST-622, Used to identify building number

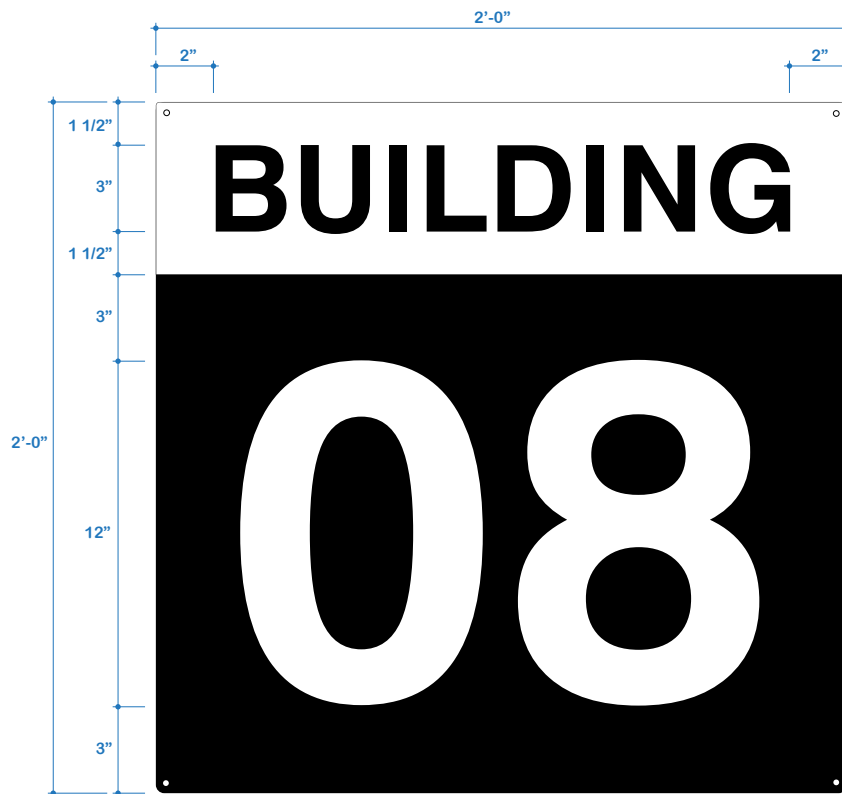

- .063 aluminum panel with 1/4" rounded edges, silk screened.
- Black background with white header.
- Swiss 721 Cn BT font.
- Mechanically fasten to exterior wall 12" from roof measured to top of sign.
- Four 1/8" diameter mounting holes located 3/8" from edge.



## Section 6

### Sign Box Detail Standards

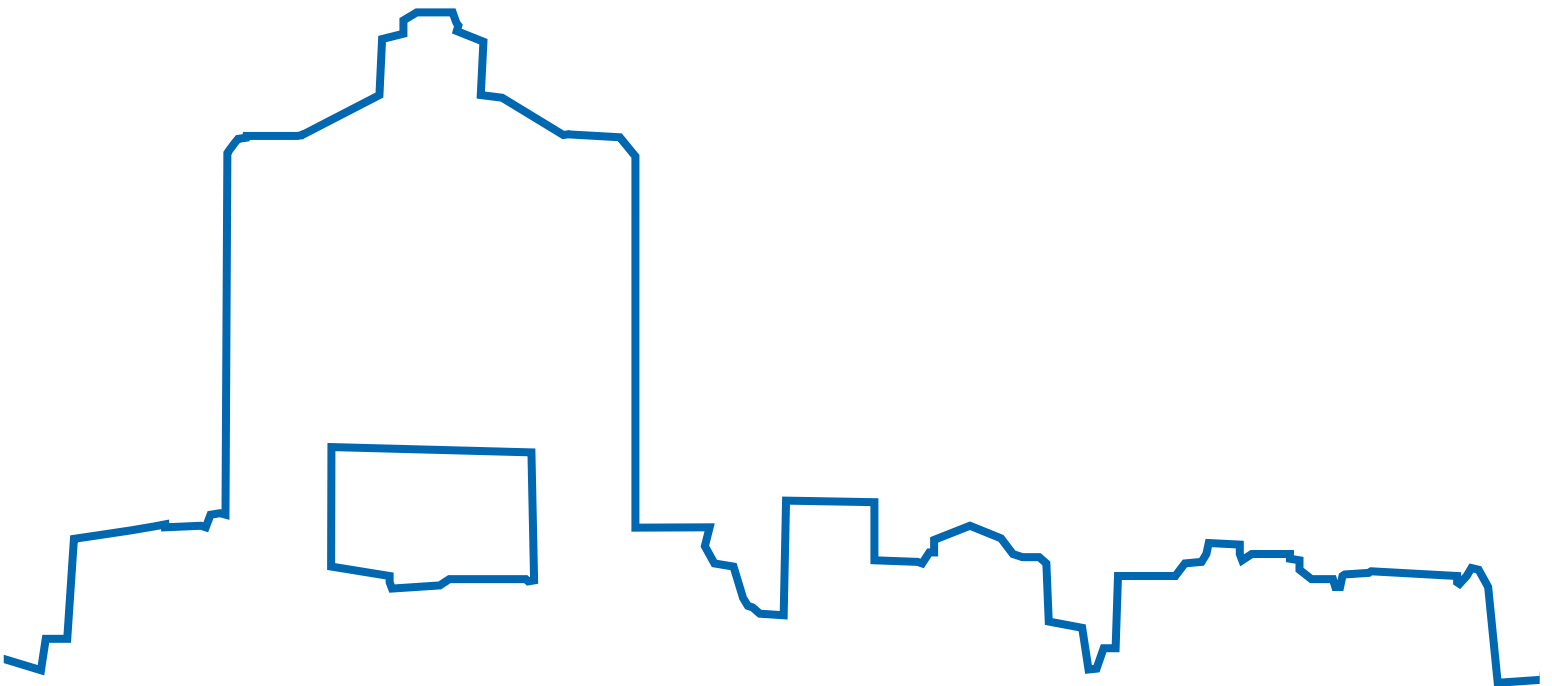

## **SIGN BOX DETAIL STANDARDS**

A selection of standard sign boxes and fabrication details have been established by Massport to be used when implementing the wayfinding signage system at Massport airports. Included within the standards is general criteria and design intent for the fabrication of standard sign boxes. However, it is the responsibility of the consultant to ensure the integrity of the sign and its mounting.

Standard sign boxes have been established for the following areas of the airport:

- Terminals
- Curbsides
- Parking
- Roadways

The standard sign boxes included are designed for maximum flexibility and work with a number of different sign applications in various areas of the airport. Where the same signs are located in different areas of the airport, the sign box type will consistently carry the same sign box type designation regardless of which sub-section they are located in. For example, Sign Box Type A can be used in Terminals, Curbsides, or Parking Garages, and the information and details shown are the same in all three sections.

The selection of standard sign boxes include:

### **Overhead Sign Boxes**

#### **Sign Box Type A - Ceiling Mounted**

Sign Box Type A-1 - Length up to 6'-0"

Sign Box Type A-2 - Length up to 12'-0"

Sign Box Type A-3 - Length up to 18'-0"

#### **Sign Box Type A-I - Ceiling Mounted - Internally Illuminated**

Sign Box Type A-1-I - Length up to 6'-0"

Sign Box Type A-2-I - Length up to 12'-0"

Sign Box Type A-3-I - Length up to 18'-0"

**Sign Box Type B - Soffit Mounted**

- Sign Box Type B-1 - Length up to 6'-0"
- Sign Box Type B-2 - Length up to 12'-0"
- Sign Box Type B-3 - Length up to 18'-0"

**Sign Box Type C - Cantilever Mounted**

- Sign Box Type C-1 - Length up to 6'-0"
- Sign Box Type C-2 - Length up to 12'-0"

**Overhead Specialty Sign Boxes**

**Sign Box Type D**

- Sign Box Type D-121 - Primary Directional
- Sign Box Type D-153 - Gate ID - Airline Listing
- Sign Box Type D-154 - Gate ID
- Sign Box Type D-213 - Primary Directional Airline Listing
- Sign Box Type D-251 - Terminal ID - Airline Listing
- Sign Box Type D-252 - Terminal ID - Airline Listing

**Over-Roadway Sign Boxes**

**Sign Box Type E**

- Sign Box Type E-1 - Length up to 12'-0"
- Sign Box Type E-2 - Length up to 18'-0"

**Flags**

**Sign Box Type F**

- Sign Box Type F-1 - Wall Flag - Aluminum Face
- Sign Box Type F-2 - Wall Flag - Acrylic Face
- Sign Box Type F-3 - Wall Flag - Aluminum Face with Header Band
- Sign Box Type F-4 - Ceiling Flag - Aluminum Face with Header Band

**Plaques**

**Sign Box Type G**

- Sign Box Type G-1 - Plaque - Acrylic Face
- Sign Box Type G-2 - Plaque - Aluminum Face
- Sign Box Type G-3 - Plaque - Aluminum Brake-Formed Pan

### Column Wrap Sign Boxes

#### Sign Box Type H

Sign Box Type H - Column Wrap

### Roadway Sign Boxes

#### Sign Box Type R

Sign Box Type R-1 - Overhead Mounted

Sign Box Type R-2 - Cantilever Mounted

Sign Box Type R-3 - Post Mounted

### Specialty Sign Boxes

#### Sign Box Type S

Sign Box Type S-164 - Pin Letters

Sign Box Type S-184 - Informational Directory

Sign Box Type S-281 - Ground Transportation Directory

Sign Box Type S-365 - Terminal Icon - Ground Mounted

Sign Box Type S-366 - Floor Level ID Pylon

Sign Box Type S-370 - Terminal Icon - Surface Mounted

Sign Box Type S-452 - Gore

Sign Box Type S-501 - Vehicular Roadside - Directional

Sign Box Type S-551 - Vehicular Facade - Building Identification

## 6.1 TERMINAL SIGN BOXES

Sign Box Types at Airport Terminals include:

### Overhead Sign Boxes

Sign Box Type A - Ceiling Mounted

Sign Box Type A-I - Ceiling Mounted - Internally Illuminated

Sign Box Type B - Soffit Mounted

Sign Box Type C - Cantilever Mounted

### Overhead Specialty Sign Boxes

Sign Box Type D-121 - Primary Directional

Sign Box Type D-153 - Gate ID - Airline Listing

Sign Box Type D-154 - Gate ID

### Flags

Sign Box Type F-1 - Wall Flag - Aluminum Face

Sign Box Type F-2 - Wall Flag - Acrylic Face

Sign Box Type F-3 - Wall Flag - Aluminum Face with Header Band

Sign Box Type F-4 - Ceiling Flag - Aluminum Face with Header Band

### Plaques

Sign Box Type G-1 - Plaque - Acrylic Face

Sign Box Type G-2 - Plaque - Aluminum Face

### Specialty Sign Boxes

Sign Box Type S-164 - Pin Letters

Sign Box Type S-184 - Informational Directory

*The drawings shown in this section are available for digital download by clicking on the link on each drawing.*

## Overhead Sign Boxes (Sign Types A, B, and C)

### Usage and Application

Overhead Sign Boxes are used for the majority of wayfinding signs located throughout the airport. They are designed to be easily customized to accommodate any message length or location. Overhead Sign Boxes are used with the following sign applications.

#### Primary Messages

- Identification
- Directional
- Informational

#### Secondary Messages

- Identification
- Directional
- Informational

### Methodology

Overhead Sign Boxes use standard aluminum extrusions that are reinforced with bent aluminum forks. The material of the sign face for these sign boxes is acrylic. The detailing of the sign boxes vary depending on length of the sign box, method of mounting the sign box, and whether or not the sign box is illuminated.

### Mounting Types

There are three ways these sign boxes are mounted:

**Mount Type A** is suspended from the ceiling.

**Mount Type B** is attached to a soffit or a wall.

**Mount Type C** is cantilevered from a wall or other structure.

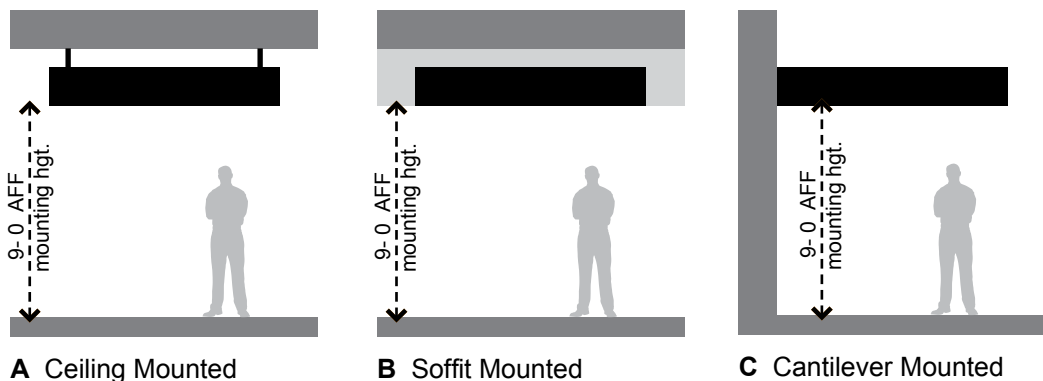

The mount type changes the internal reinforcing of the sign box independent of the length of the sign box.



**Length Types**

There are three length types for these sign boxes:

**Length Type 1** is up to 6 feet in length.

**Length Type 2** is from 6 feet to 12 feet in length.

**Length Type 3** is from 12 feet to 18 feet in length.

The height of the sign box is independent of the sign type. All sign box types can accommodate up to 3 lines of messaging and a header. Heights beyond 3'-0" and lengths beyond the table below for Mount Types A and B are considered custom. Lengths beyond 12'-0" for Mount Type C are also considered custom.

Length Type	12	3
Header (when applicable)		
One Line Sign		
Two Line Sign		
Three Line Sign		
Sign Length	6 ft.	12 ft. 18 ft.

**Illumination**

All overhead sign boxes can be internally illuminated if desired. Illumination and lighting details vary based on the length of the box and whether or not the sign box is double sided. Depending on the technology at the time of fabrication, a larger extrusion may need to be used to increase the distance between the LEDs and the sign face to avoid hot spots. A lighting diagram is provided for Sign Box Type A and is shown for a double sided internally illuminated sign, but the same concept can be applied to a single sided internally illuminated sign, or Box Types B and C.

**Sign Box Type Designation**

The Sign Box Type designation for Overhead Sign Boxes are a combination of Mount Type, Length Type, and whether or not the sign box is illuminated.

**Mount Type - Length Type - Illumination**



Illuminated sign boxes are given an “I” to indicate that a box contains illumination details. Non-illuminated sign boxes receive no designation and are either lit through ambient light or direct external illumination.

An example of a 12 foot, 2-line illuminated cantilever mounted sign box is Sign Box Type C-2-I. The “C” denotes a cantilever mounting, the “2” denotes a 12-foot-long sign box, and “I” denotes illumination. This nomenclature should appear in the contract documents.

Overhead Sign Box Drawings

Details for Sign Box Types A-1, A-2, and A-3 (Ceiling Mounted)

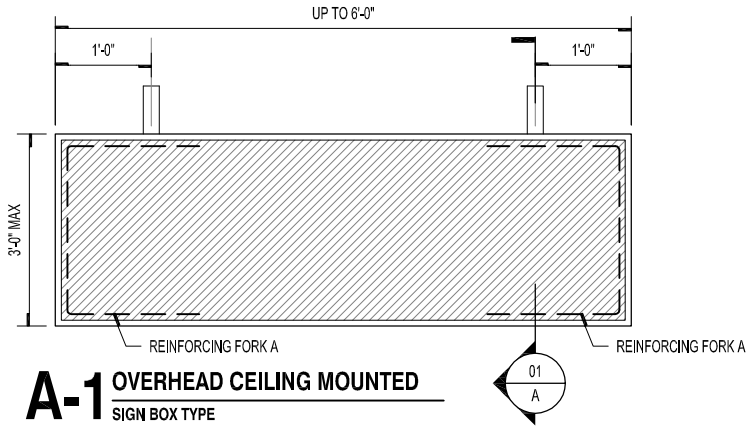

NOTE: SEE REINFORCING DETAILS FOR REINFORCING TYPES AND EXTRUSION DETAILS FOR EXTRUSION TYPES.

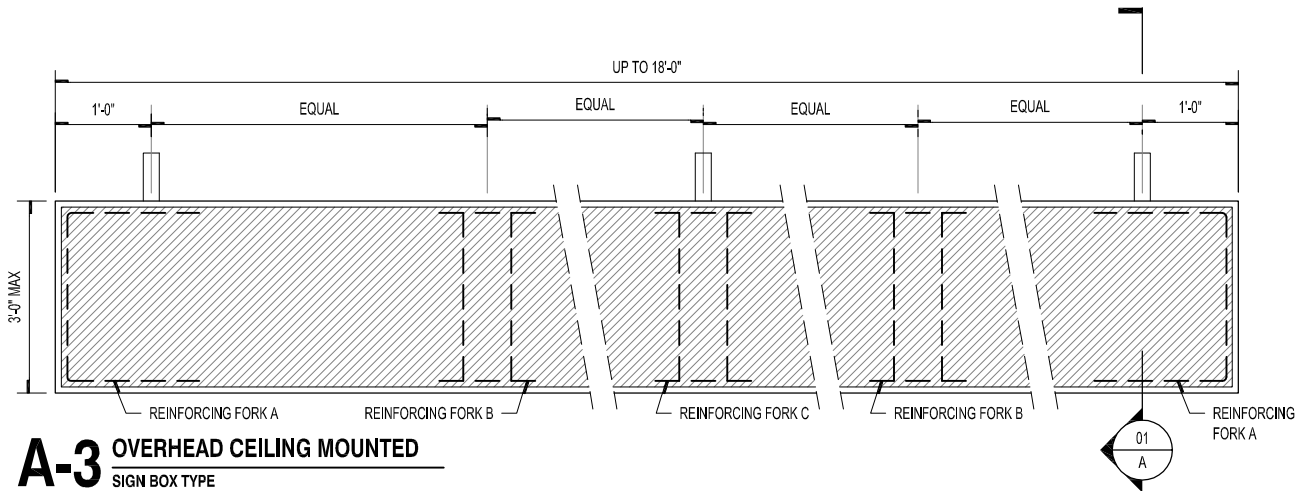
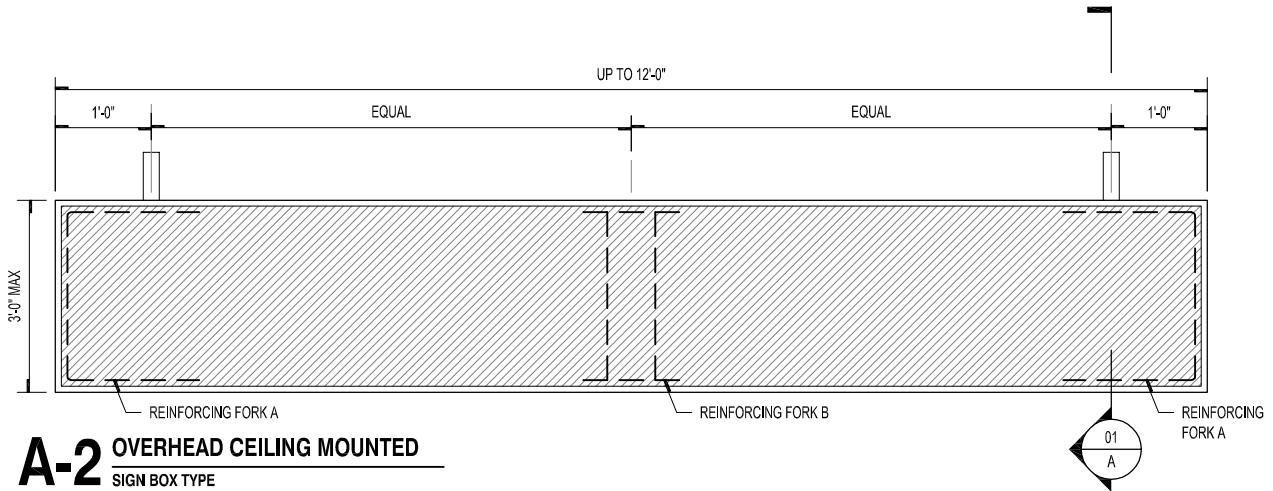

Fabrication Details for Sign Box Types A-1, A-2, and A-3

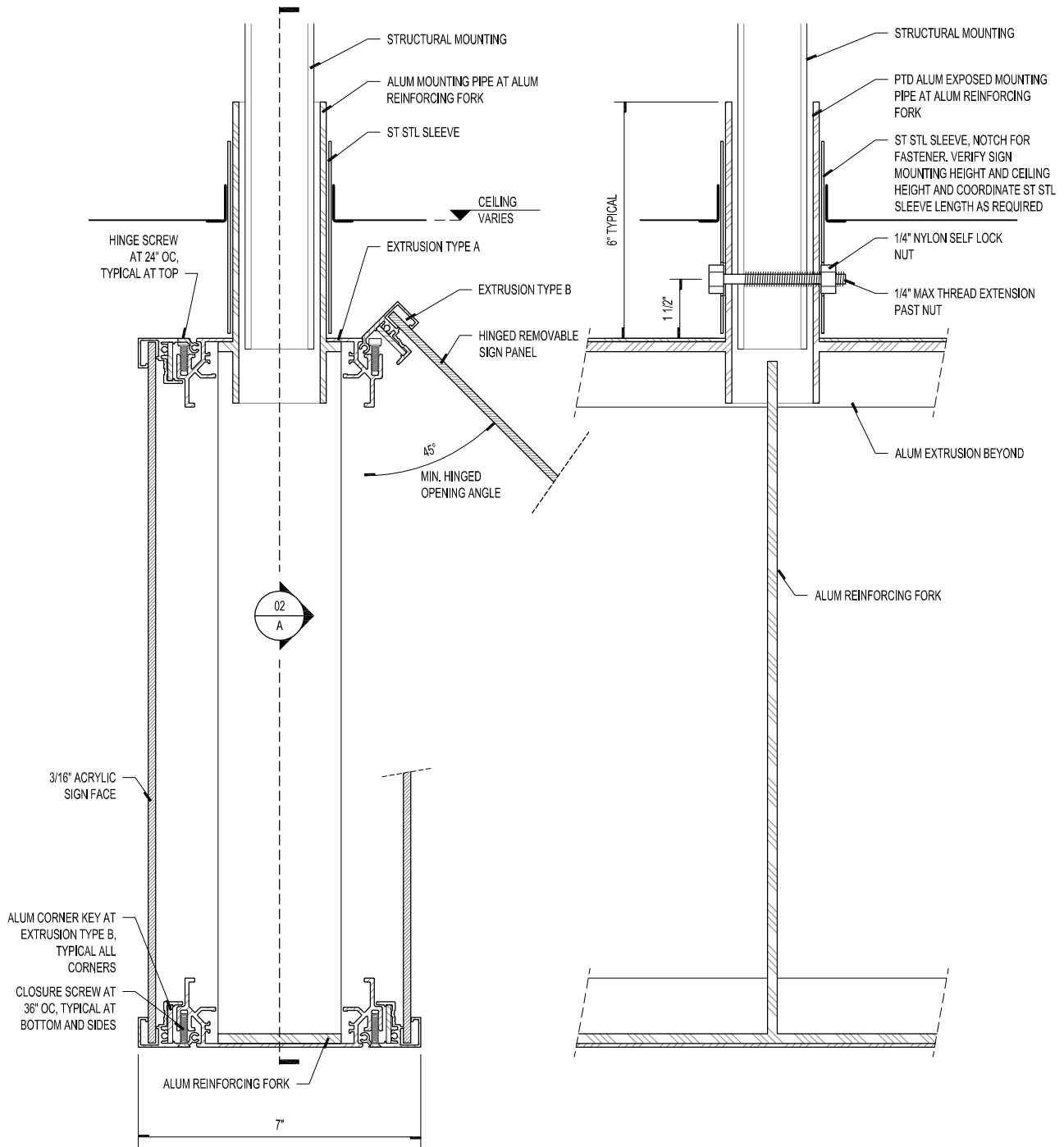

**01** SIGN BOX TYPES A-1, A-2, AND A-3  
TYPICAL SECTION

**02** SIGN BOX TYPES A-1, A-2, AND A-3  
TYPICAL SECTION



Lighting Diagram for Sign Box Types A-1-I, A-2-I, and A-3-I

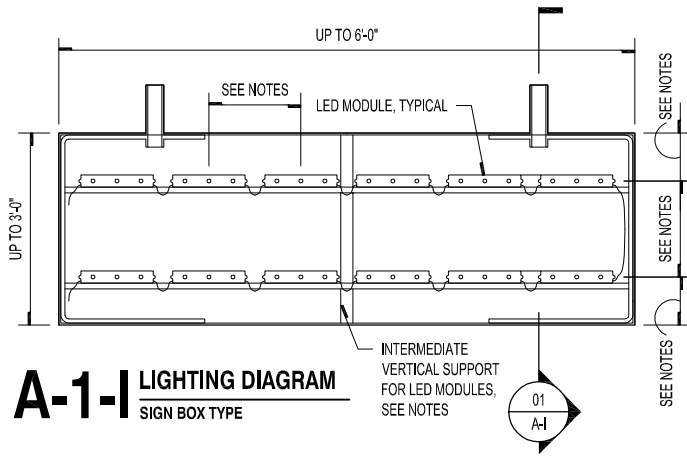

**A-1-I** LIGHTING DIAGRAM  
SIGN BOX TYPE

- NOTES:
1. LED MODULES SHOWN ON BOX TYPE A. ILLUMINATION CONCEPT APPLIES TO BOX TYPES A, B, AND C.
  2. LAYOUT SHOWN FOR A BOX HEIGHT OF 2'-0". ADJUST NUMBER OF LED MODULES AND SPACING AS REQUIRED FOR BOX TYPES ABOVE AND BELOW 2'-0" IN HEIGHT.
  3. SPACE LED MODULES AS RECOMMENDED BY LED MODULE MANUFACTURER.
  4. PROVIDE INTERMEDIATE VERTICAL SUPPORTS EVERY 4'-0" O.C. OR AS RECOMMENDED BY LED MODULE MANUFACTURER. COORDINATE LOCATION OF SUPPORTS WITH LED MODULES TO PROVIDE EVEN ILLUMINATION AVOIDING SHADOWS AND HOT SPOTS.
  5. SEE REINFORCING DETAILS FOR REINFORCING TYPES AND EXTRUSION DETAILS FOR EXTRUSION TYPES.

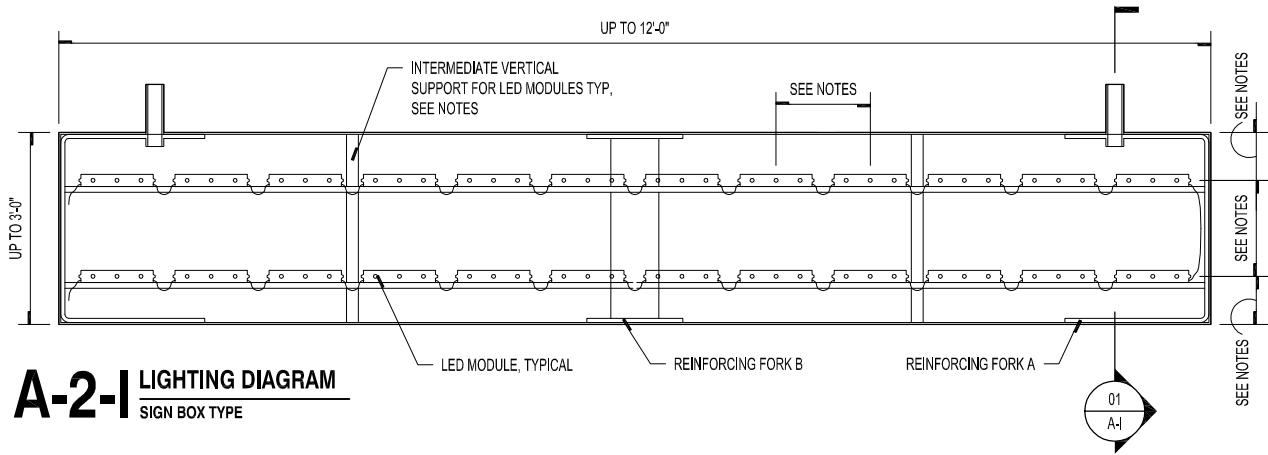

**A-2-I** LIGHTING DIAGRAM  
SIGN BOX TYPE

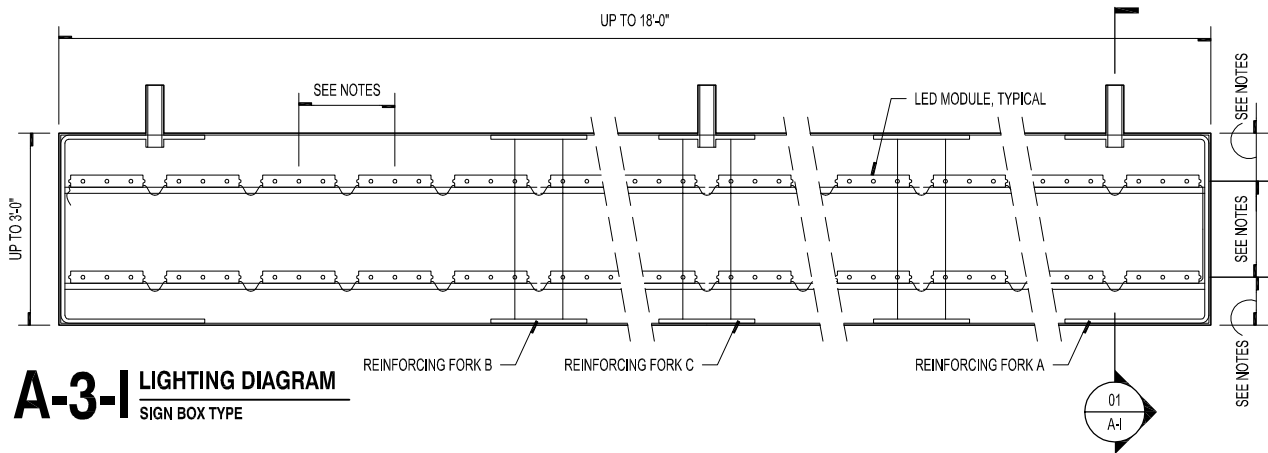

**A-3-I** LIGHTING DIAGRAM  
SIGN BOX TYPE

**Fabrication Details for Sign Box Types A-1-I, A-2-I, and A-3-I (Ceiling Mounted)**

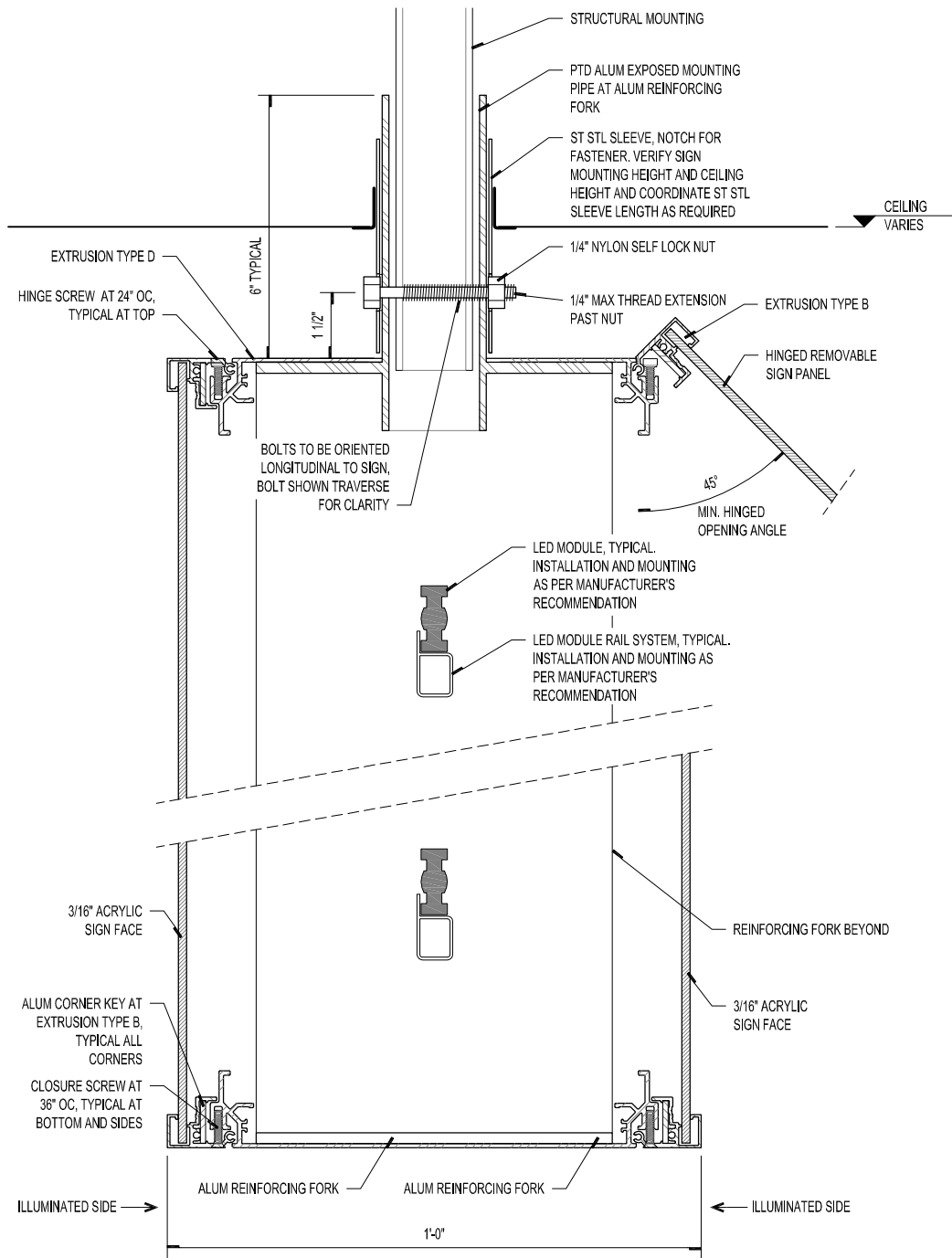

**01** SIGN BOX TYPE A-1-I, A-2-I, AND A-3-I  
TYPICAL SECTION

Details for Sign Box Types B-1, B-2, and B-3 (Soffit Mounted)

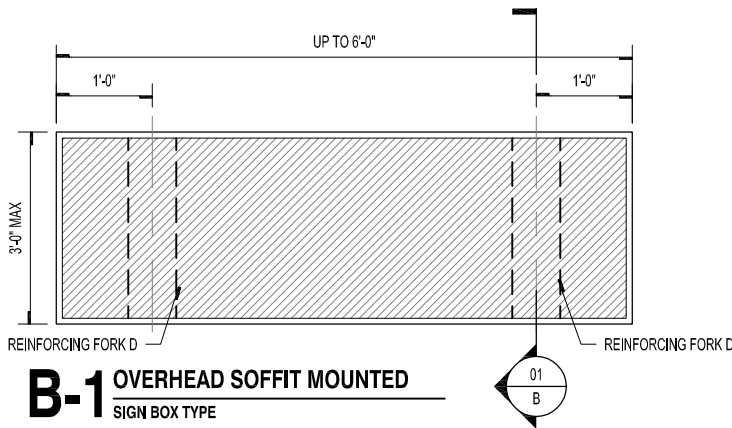

NOTE: SEE REINFORCING DETAILS FOR REINFORCING TYPES AND EXTRUSION DETAILS FOR EXTRUSION TYPES.

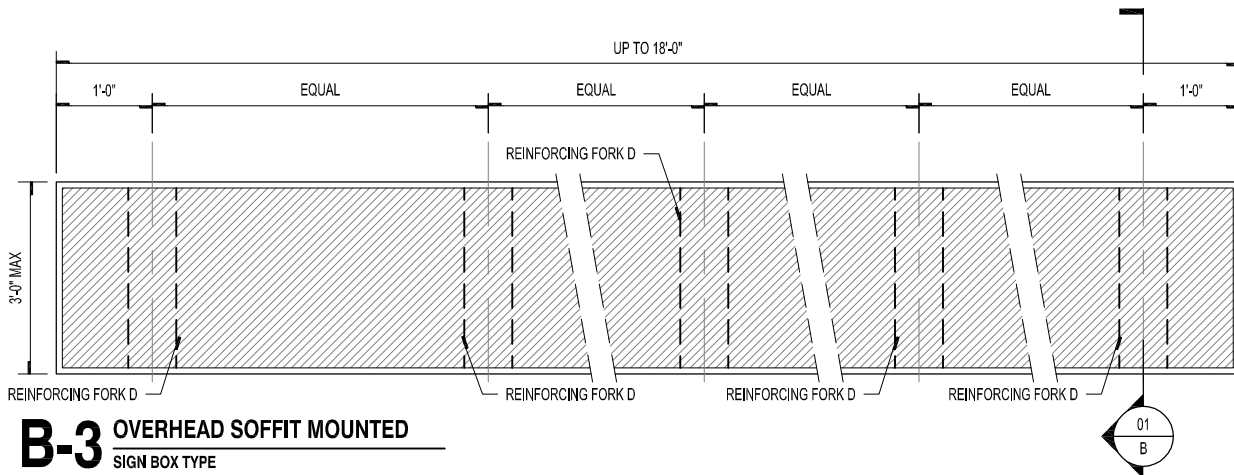
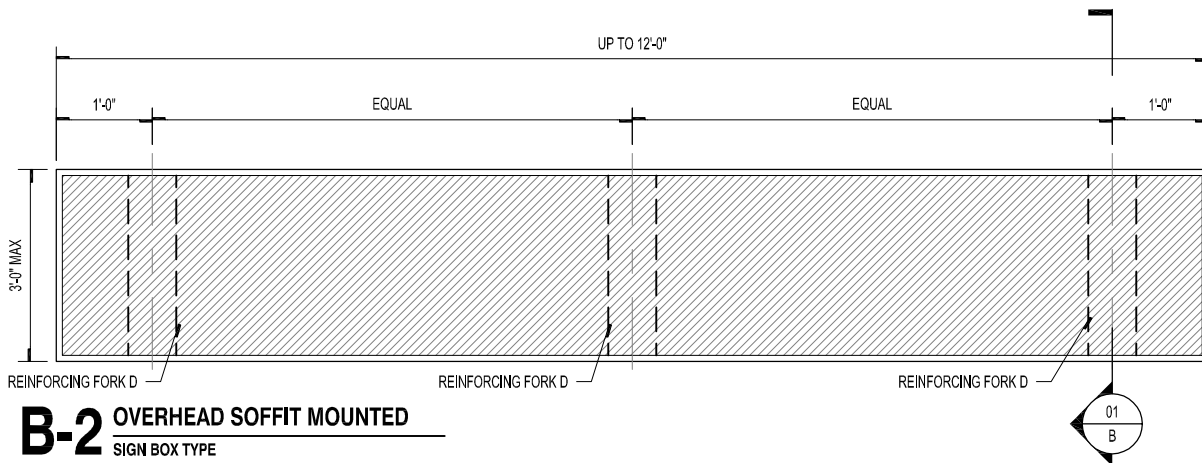

**Fabrication Details for Sign Box Types B-1, B-2, and B-3**

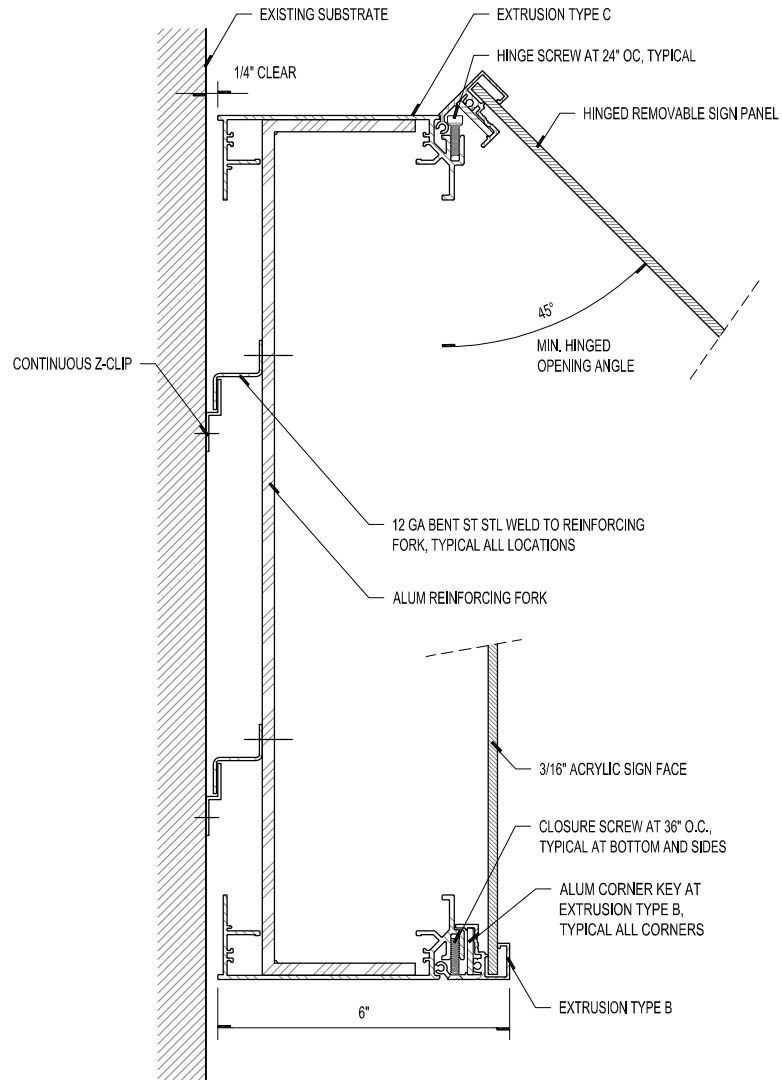

**01** SIGN BOX TYPES B-1, B-2, AND B-3  
TYPICAL SECTION



Details for Sign Box Types C-1 and C-2 (Cantilever Mounted)

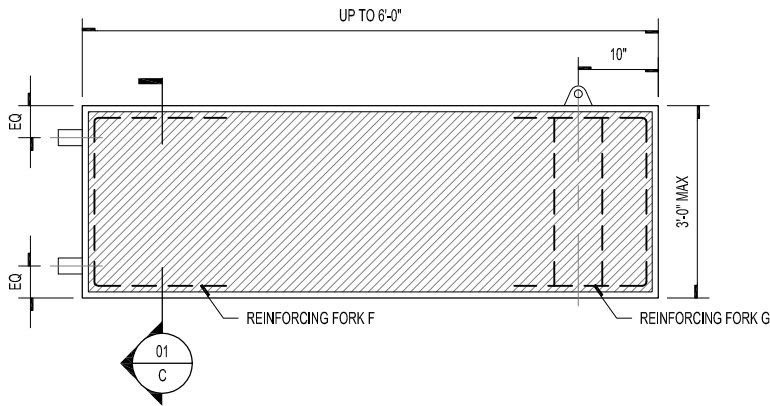

NOTE: SEE REINFORCING DETAILS FOR REINFORCING TYPES AND EXTRUSION DETAILS FOR EXTRUSION TYPES.

**C-1** OVERHEAD CANTILEVER MOUNTED  
SIGN BOX TYPE

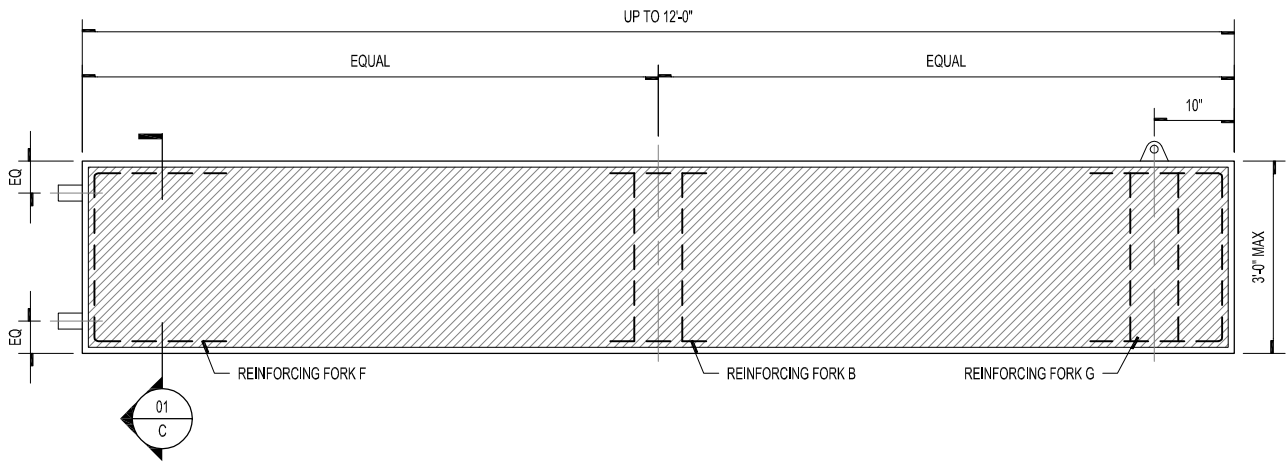

**C-2** OVERHEAD CANTILEVER MOUNTED  
SIGN BOX TYPE

*Fabrication Details for Sign Box Types C-1 and C-2*

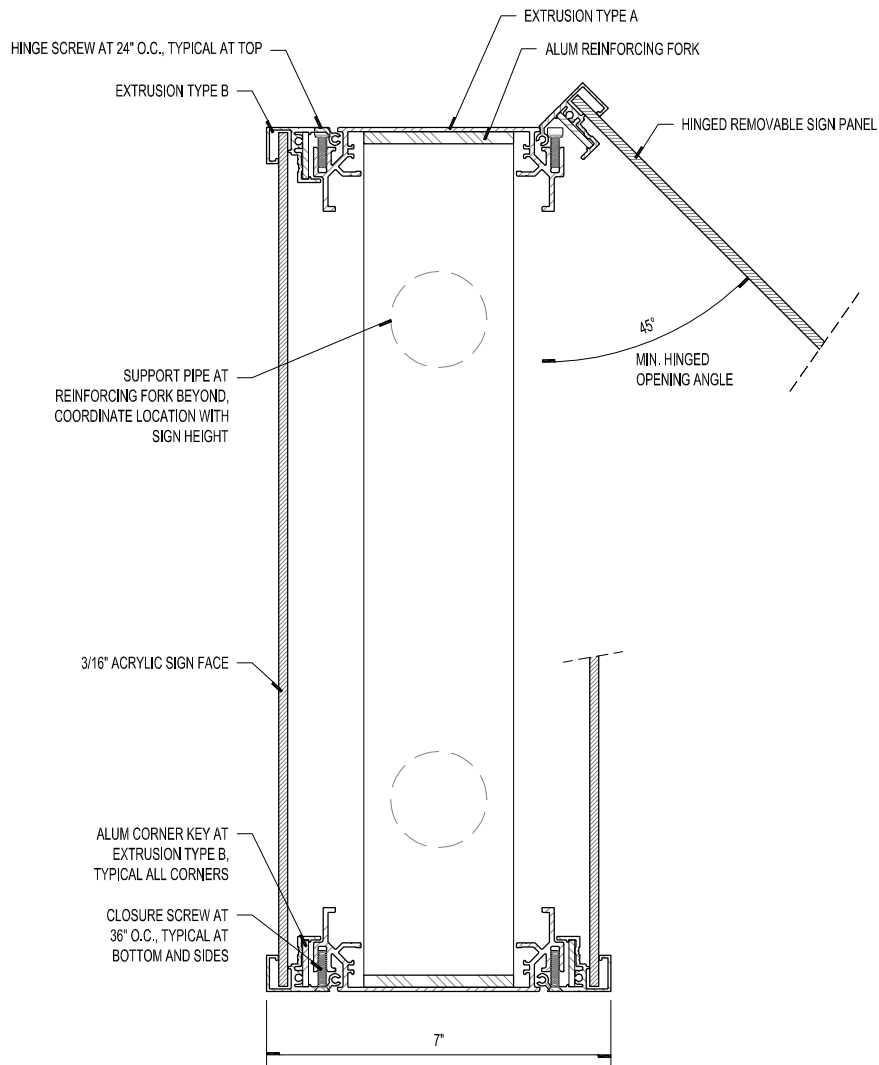

**01** SIGN BOX TYPES C-1 AND C-2  
TYPICAL SECTION

Reinforcing Details for Overhead Sign Boxes

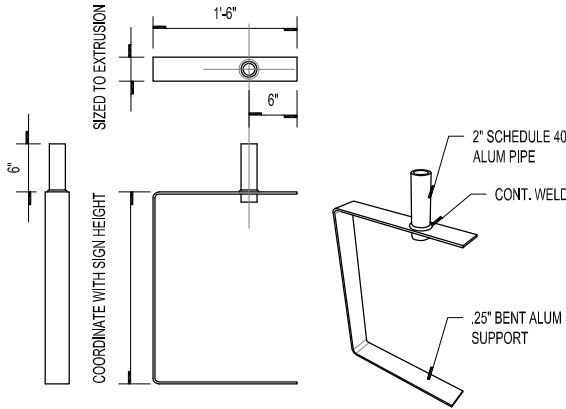

**01** REINFORCING FORK A

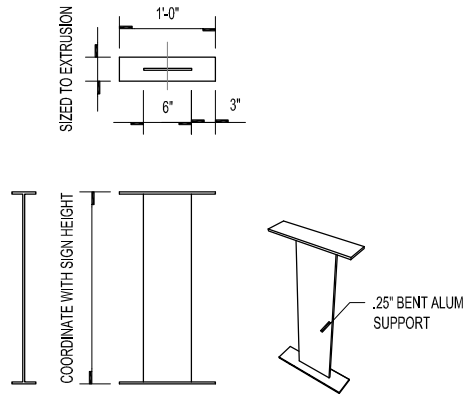

**02** REINFORCING FORK B

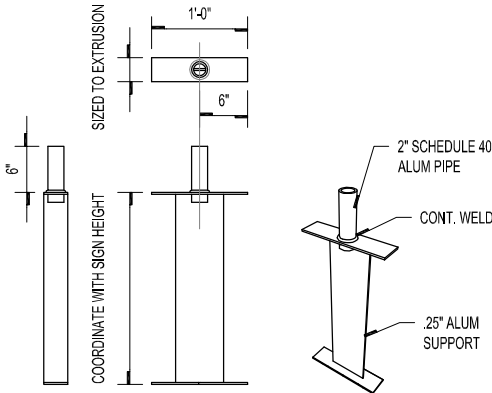

**03** REINFORCING FORK C

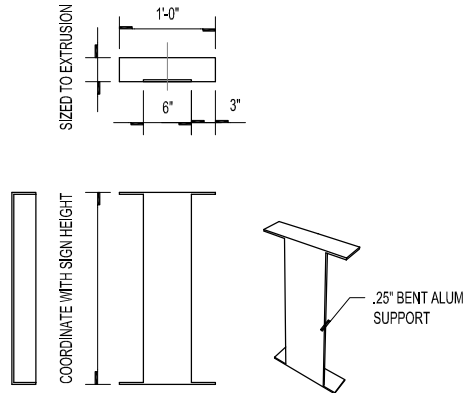

**04** REINFORCING FORK D

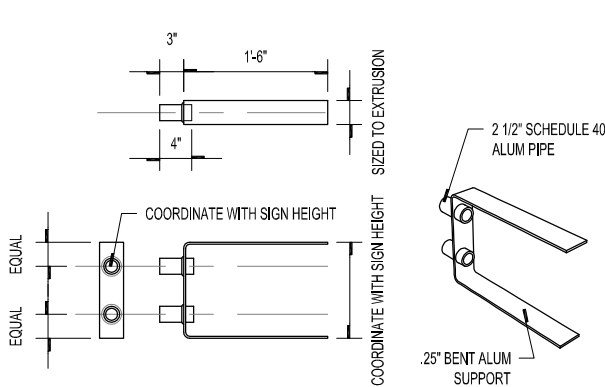

**05** REINFORCING FORK F

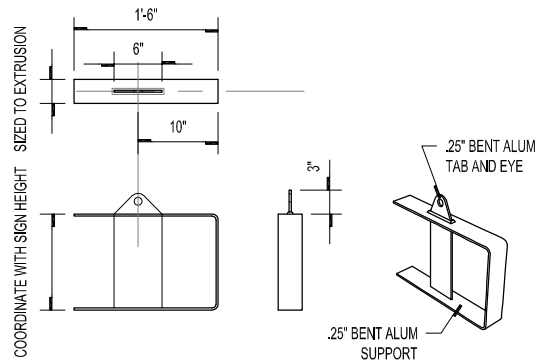

**06** REINFORCING FORK G

*Extrusion Types for Overhead Sign Boxes*

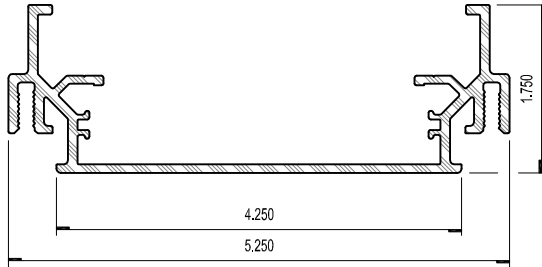

**01** EXTRUSION TYPE A  
SIGNCOMP SERIES 7

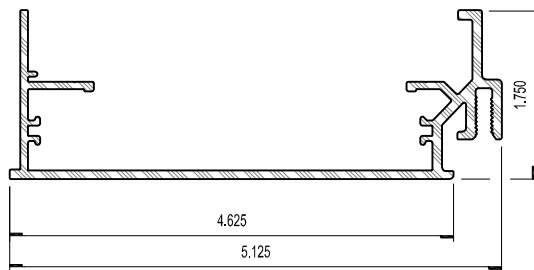

**02** EXTRUSION TYPE C  
SIGNCOMP SERIES 7

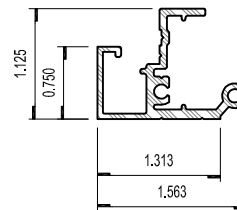

**03** EXTRUSION TYPE B  
SIGNCOMP SERIES 7

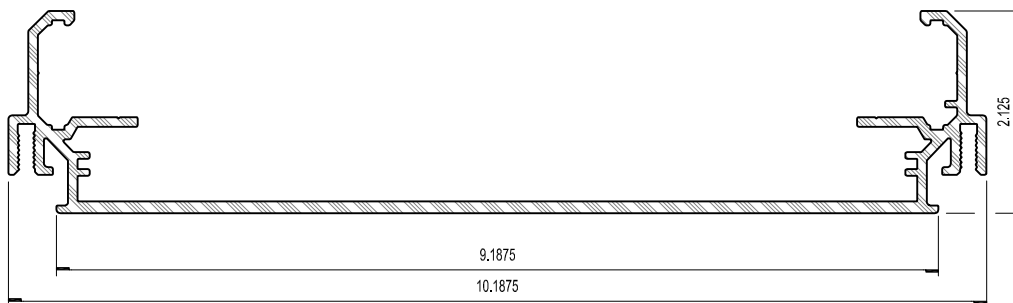

**04** EXTRUSION TYPE D  
SIGNCOMP SERIES 12 - HINGE BODY

## Overhead Specialty Sign Boxes (Sign Type D)

### Usage and Application

Overhead Specialty Sign Boxes are used with the following sign applications.

#### Primary Messages

- Identification
- Directional
- Informational

#### Secondary Messages

- Identification
- Directional
- Informational

### Methodology

Overhead Specialty Sign Boxes are custom sign boxes that are specific to their sign application. They are detailed using the same methodology as Sign Box Types A, B, and C and use standard aluminum extrusions reinforced with bent aluminum forks.

Signs within this group are typically internally illuminated and include a variable message system component (VMS) either on one side, both sides, or a combination of the two. Only one condition is shown for each of these sign types; however, details can be modified using the same methodology for signs with different requirements. For example, a sign may be detailed with a VMS component on both sides, but can be modified to include a VMS component only on one side if desired. As with any sign that includes a lighting or VMS component, details may need to be modified based on the current technology available at the time of fabrication.

### Mounting Types

The details shown for these sign box types are for signs suspended from the ceiling. Because these sign box types use the same methodology as Sign Box Types A, B, and C, any one of these signs can be modified to be surface mounted to a soffit or wall, or cantilevered from a wall or structure.

### Sign Box Type Designation

Because these sign box types are specific to their sign application, the numerical designation for this category corresponds to the Sign Face Type designation shown in Section 5. For example, Sign Box Type D-121 is the sign box for Sign Face ST-121.

### Sign Box Types

**Sign Box Type D-121** is a primary directional overhead sign that includes a variable message system component. The details shown for this sign box type are for a double-sided sign with VMS and illumination on both sides. However, the sign box can be modified using the same methodology for signs requiring VMS and illumination only on one side. In this case, smaller aluminum extrusions may be used.

The corresponding Sign Face Type for this sign box type is ST-121.

**Sign Box Type D-153** is a Gate ID - Airline Listing sign. This sign is an internally illuminated sign that includes a VMS component. The details shown for this sign box type are for a double-sided sign with VMS on one side and illumination on both sides.

The corresponding Sign Face Type for this sign box type is ST-153.

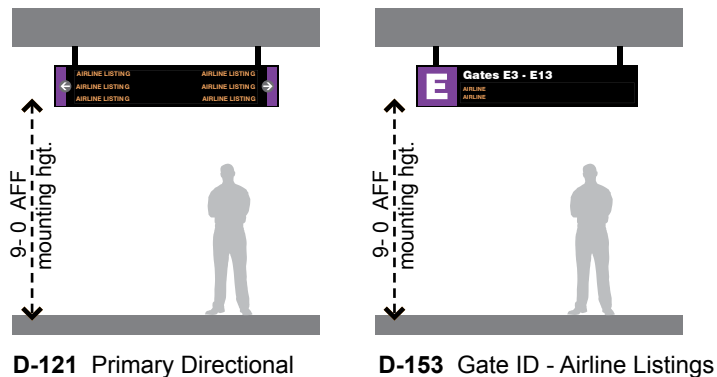

Overhead Specialty Sign Box Drawings

Details for Sign Box Types D-121 - Primary Directional Overhead Sign

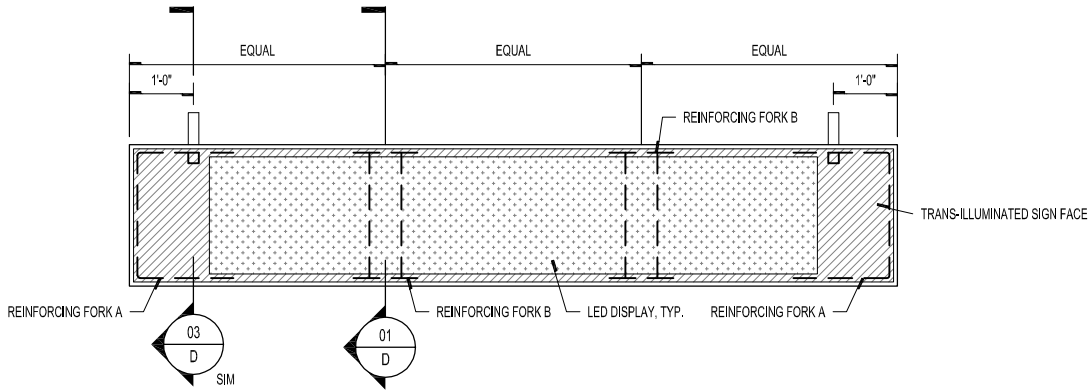

**D-121** ILLUMINATED AND VARIABLE MESSAGE SYSTEM SIGN - SIDE A  
SIGN BOX TYPE

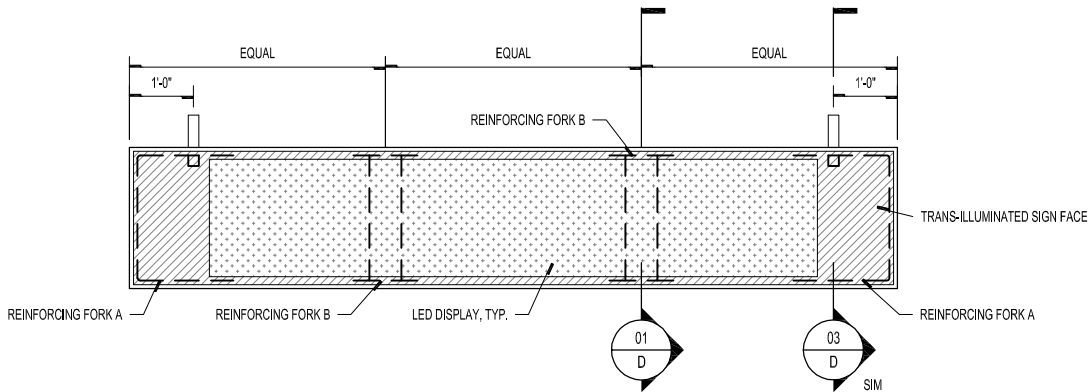

**D-121** ILLUMINATED AND VARIABLE MESSAGE SYSTEM SIGN - SIDE B  
SIGN BOX TYPE



**D-121** LIGHTING DIAGRAM  
SIGN BOX TYPE

- NOTE:
1. PROVIDE SERVICE SWITCH, TYPICAL ALL POWERED SIGNS
  2. PROVIDE INTERIOR METAL RACEWAYS FOR ALL ELECTRICAL WIRING AND SIGNAL WIRING.
  3. SPACE LED MODULES AS RECOMMENDED BY LED MODULE MANUFACTURER.
  4. PROVIDE INTERMEDIATE VERTICAL SUPPORTS EVERY 4'-0" O.C. OR AS RECOMMENDED BY LED MODULE MANUFACTURER. COORDINATE LOCATION OF SUPPORTS WITH LED MODULES TO PROVIDE EVEN ILLUMINATION AVOIDING SHADOWS AND HOT SPOTS.
  5. SEE REINFORCING DETAILS FOR REINFORCING TYPES AND EXTRUSION DETAILS FOR EXTRUSION TYPES.

Details for Sign Box Types D-153 - Gate ID - Airline Listings Sign

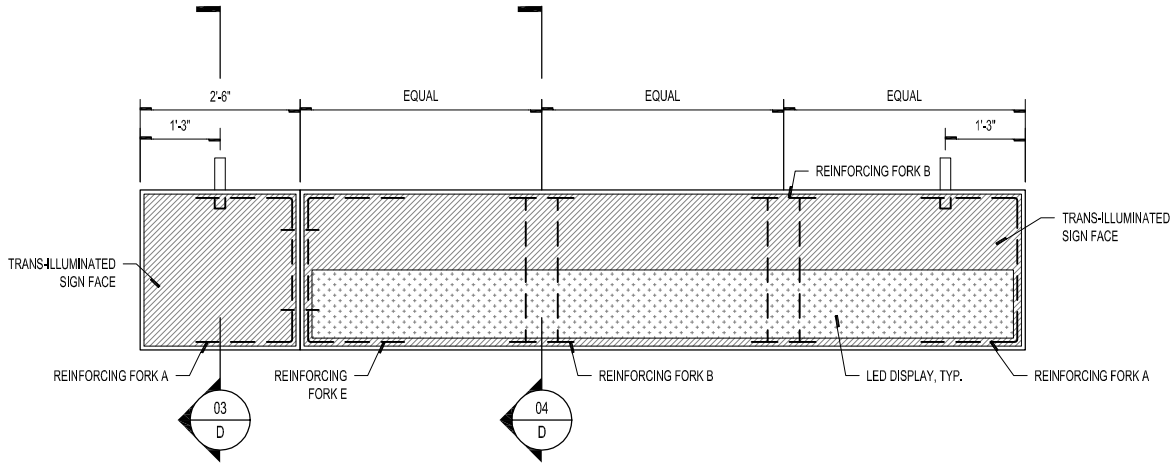

**D-153** GATE ID - AIRLINE LISTING SIGN - SIDE A  
SIGN BOX TYPE - TRANS-ILLUMINATED AND LED VARIABLE MESSAGE

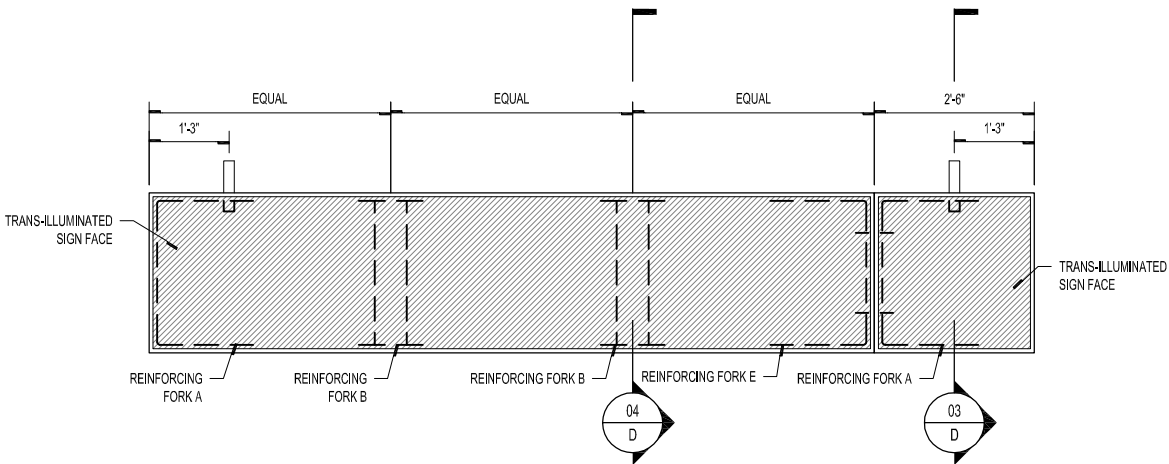

**D-153** GATE ID - AIRLINE LISTING SIGN - SIDE B  
SIGN BOX TYPE - TRANS-ILLUMINATED

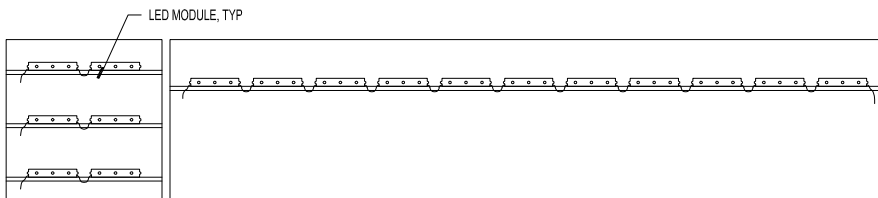

**D-153** LIGHTING DIAGRAM  
SIGN BOX TYPE

- NOTE:
1. PROVIDE SERVICE SWITCH, TYPICAL ALL POWERED SIGNS
  2. PROVIDE INTERIOR METAL RACEWAYS FOR ALL ELECTRICAL WIRING AND SIGNAL WIRING.
  3. SPACE LED MODULES AS RECOMMENDED BY LED MODULE MANUFACTURER.
  4. PROVIDE INTERMEDIATE VERTICAL SUPPORTS EVERY 4'-0" O.C. OR AS RECOMMENDED BY LED MODULE MANUFACTURER. COORDINATE LOCATION OF SUPPORTS WITH LED MODULES TO PROVIDE EVEN ILLUMINATION AVOIDING SHADOWS AND HOT SPOTS.
  5. SEE REINFORCING DETAILS FOR REINFORCING TYPES AND EXTRUSION DETAILS FOR EXTRUSION TYPES.



**Fabrication Details for Sign Box Type D - Overhead Specialty Sign Boxes**

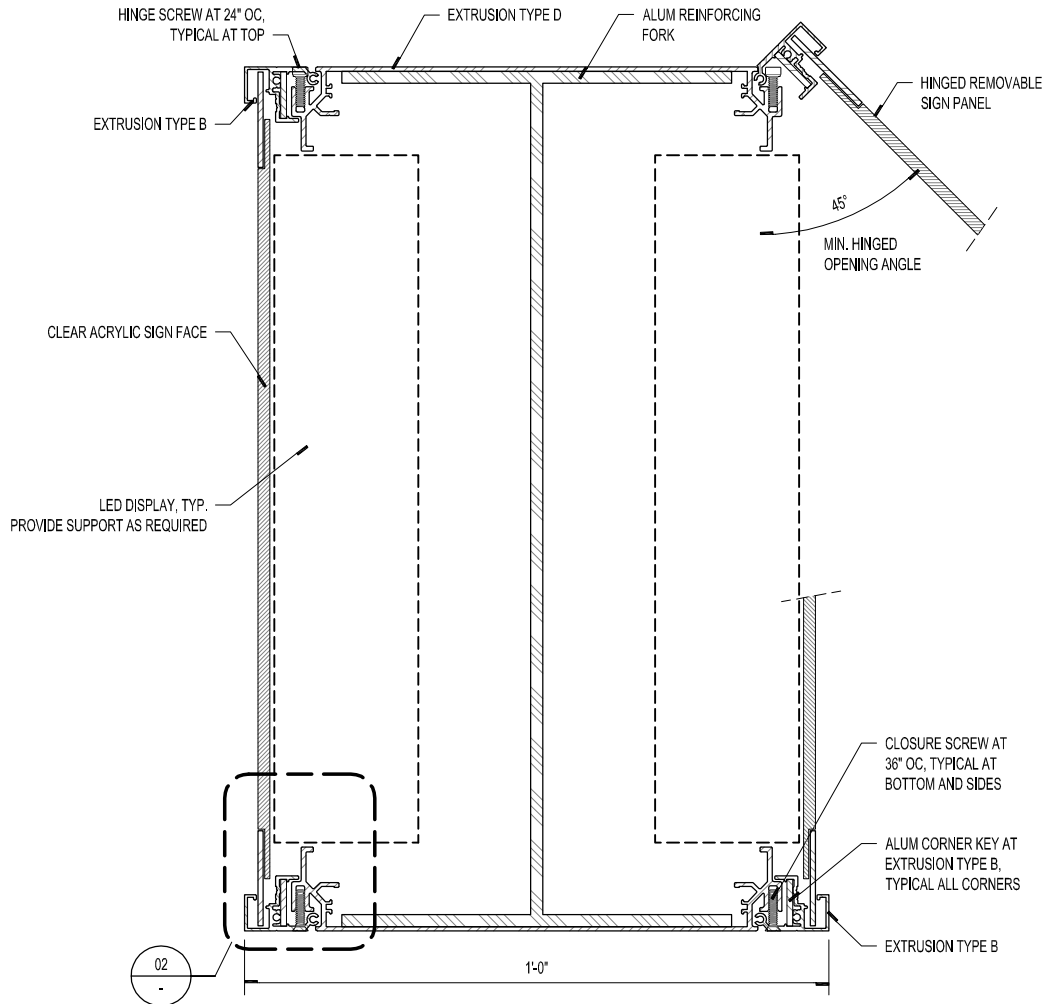

**01 SIGN BOX TYPE D AT VMS UNITS**  
TYPICAL SECTION

NOTE: PROVIDE PROP ARM TO SUPPORT HINGED SIGN PANEL DURING SERVICING, TYPICAL

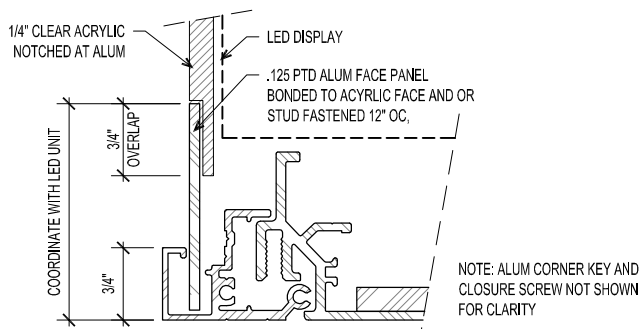

**02 SIGN FACE AT LED DISPLAY**  
TYPICAL DETAIL

Fabrication Details for Sign Box Type D - Overhead Specialty Sign Boxes

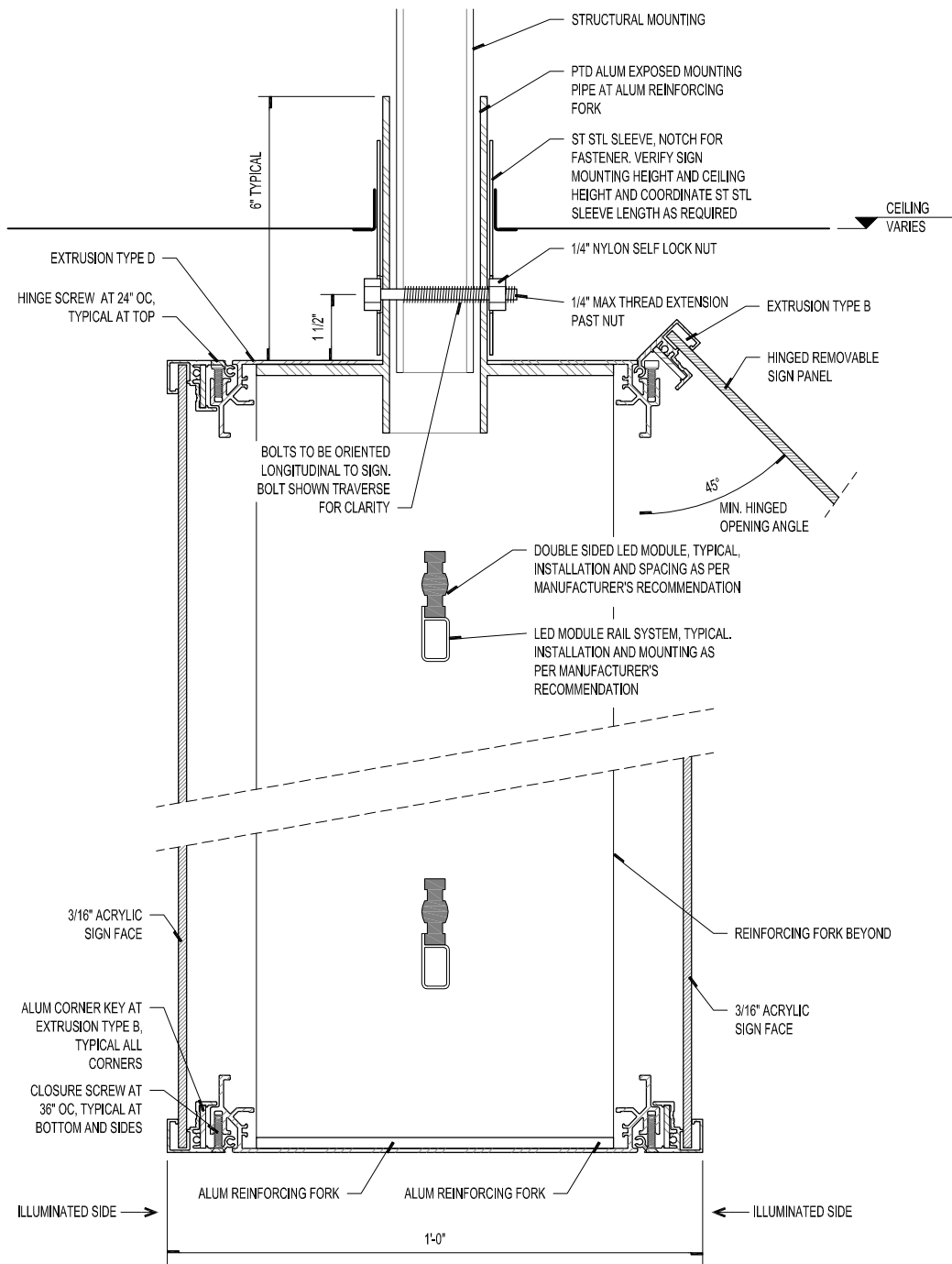

**03** SIGN BOX TYPE D AT TRANS-ILLUMINATED SIGN FACE  
TYPICAL SECTION

Fabrication Details for Sign Box Type D - Overhead Specialty Sign Boxes

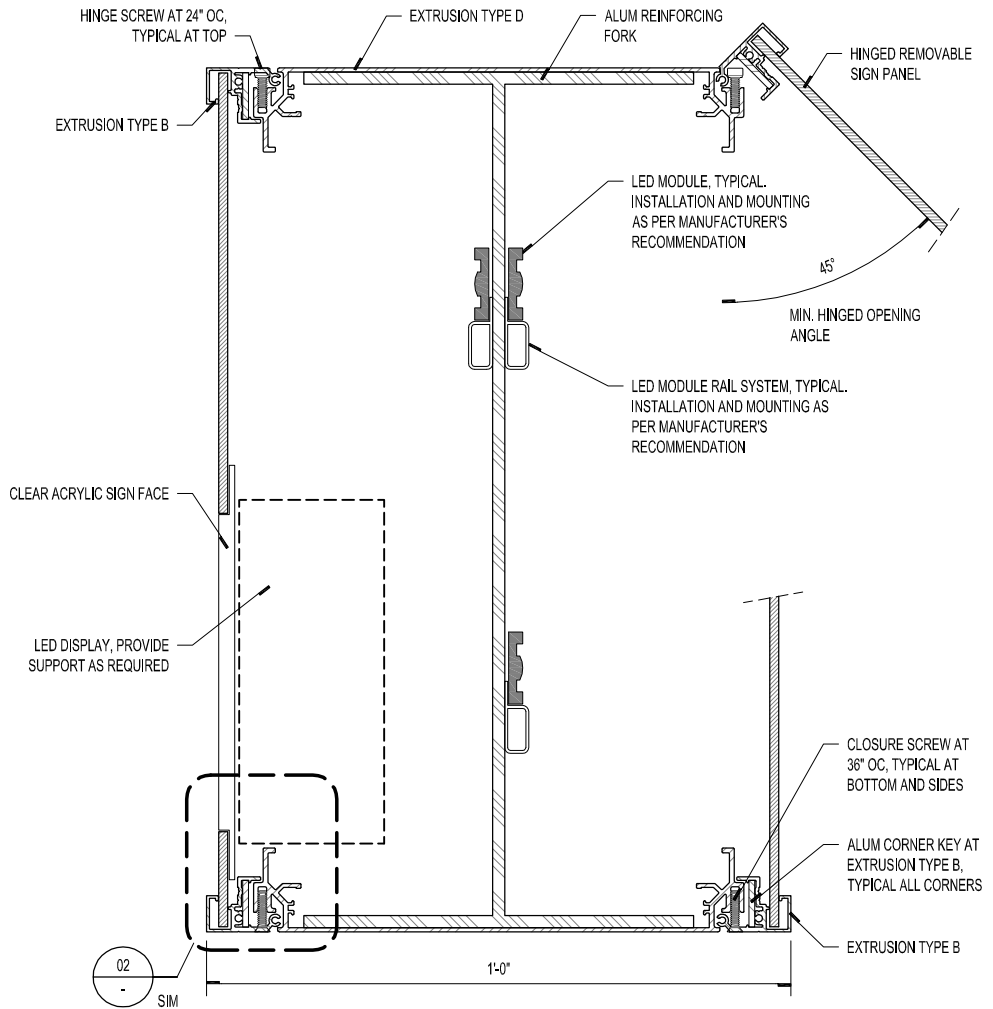

NOTE: PROVIDE PROP ARM TO SUPPORT HINGED SIGN PANEL DURING SERVICING, TYPICAL

**04** SIGN BOX TYPE D  
AT VMS UNIT AND TRANS-ILLUMINATED SIGN FACE  
TYPICAL SECTION

Reinforcing Fork Details and Extrusion Types for Sign Box Type D - Overhead Specialty Sign Boxes

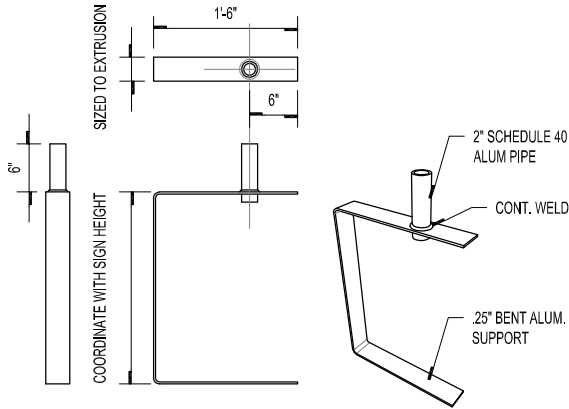

**01** REINFORCING FORK A

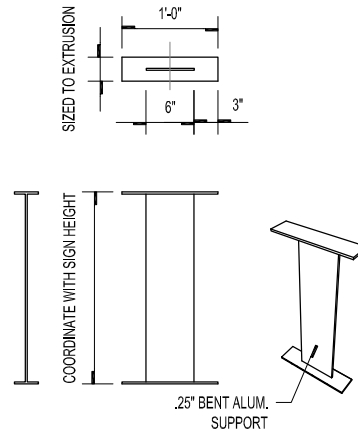

**02** REINFORCING FORK B

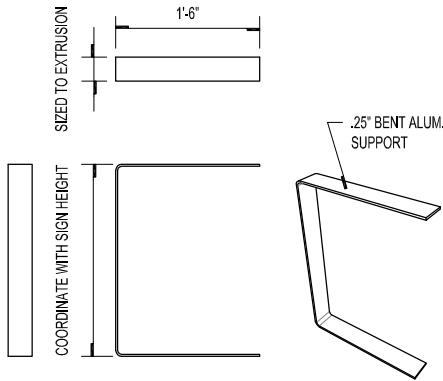

**03** REINFORCING FORK E

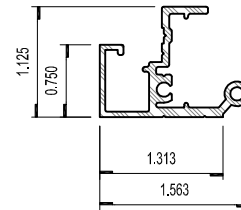

**04** EXTRUSION TYPE B  
SIGNCOMP SERIES 7

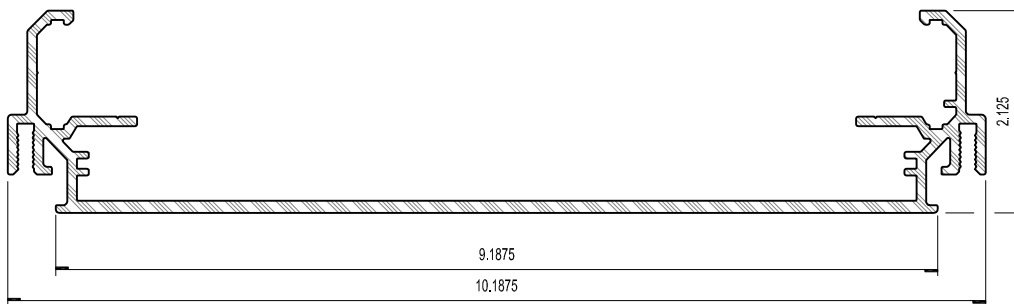

**05** EXTRUSION TYPE D  
SIGNCOMP SERIES 12 - HINGE BODY

## Flags and Plaques (Sign Box Type F and G)

### Usage and Application

Flags and Plaques are generally smaller signs used for secondary messages that are mounted to a wall or ceiling. They are used with the following sign applications:

Primary Messages	Secondary Messages
<input type="checkbox"/> Identification	<input checked="" type="checkbox"/> Identification
<input type="checkbox"/> Directional	<input checked="" type="checkbox"/> Directional
<input checked="" type="checkbox"/> Informational	<input checked="" type="checkbox"/> Informational

### Methodology

The detailing of Flags and Plaques is similar. Both signs box types consist of either an aluminum or acrylic face that is attached to an aluminum frame using ultra or very high bond (VHB) adhesive tape. The frame is constructed using aluminum angles or channels and is hidden from view behind the face. The construction of these signs allows the profile to remain thin.

### Mounting

Flags are double-faced signs suspended from either the top or side of the sign. Plaques are single-faced signs mounted to a wall or surface. Plaques are used for a variety of different sign applications that range in size, but the detailing remains the same regardless of application type.

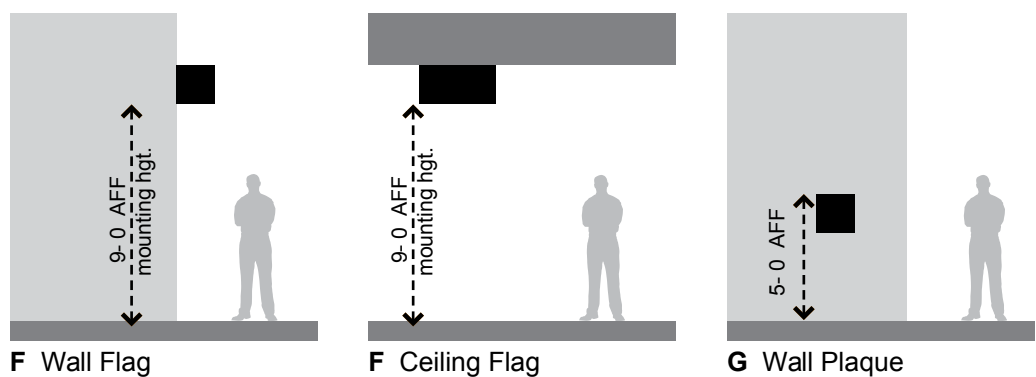

### Illumination

Neither of these sign box types are illuminated.

### **Sign Box Type Designation**

There are separate Sign Box Type designations for flags and plaques.

### **Sign Box Type F**

**Sign Type F-1** is a wall flag with a painted aluminum face and applied vinyl graphics.

**Sign Type F-2** is a wall flag with a painted acrylic face and applied vinyl graphics.

**Sign Type F-3** is a wall flag with a painted aluminum face and applied vinyl graphics. This flag has an accent header band detail.

**Sign Type F-4** is a ceiling flag with a painted aluminum face and applied vinyl graphics. This flag has an accent header band detail.

### **Sign Box Type G**

**Type G-1** is a surface mounted plaque with a painted acrylic face and applied vinyl graphics. This plaque has an accent header band detail.

**Type G-2** is a surface mounted plaque with a painted aluminum face and applied vinyl graphics.

**Type G-3** is a surface mounted photopolymer plaque with tactile characters.

Flags Sign Box Drawings

Details for Sign Box Types F-1, F-2, F-3, and F-4

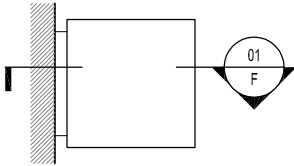

**F-1 WALL FLAG**  
SIGN BOX TYPE  
NOTE: SEE SECTION 5 FOR SIGN DIMENSIONS

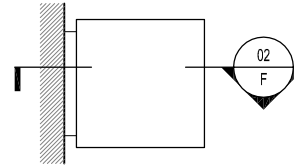

**F-2 WALL FLAG**  
SIGN BOX TYPE  
NOTE: SEE SECTION 5 FOR SIGN DIMENSIONS

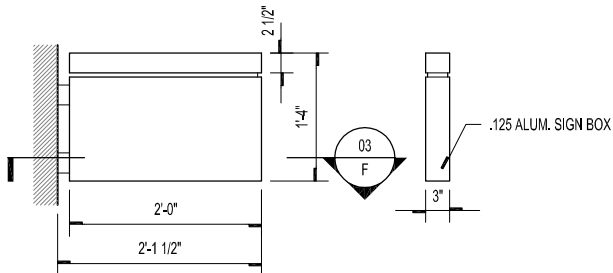

**F-3 WALL FLAG WITH HEADER**  
SIGN BOX TYPE

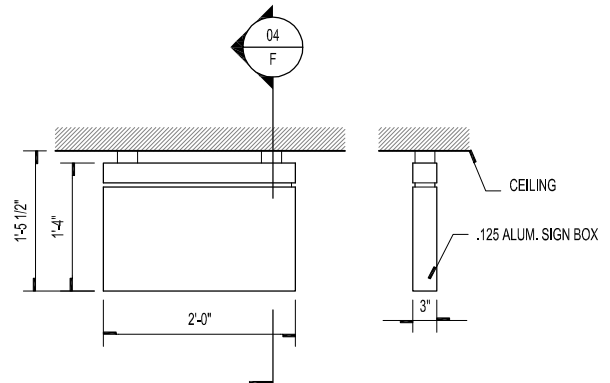

**F-4 CEILING FLAG WITH HEADER**  
SIGN BOX TYPE

Fabrication Details for Sign Box Types F-1, F-2, F-3, and F-4 - Flags

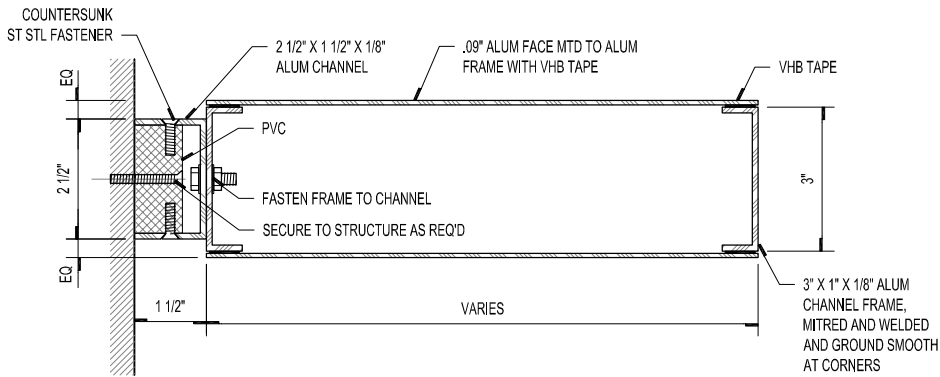

**01 SIGN BOX TYPE F-1**  
TYPICAL SECTION

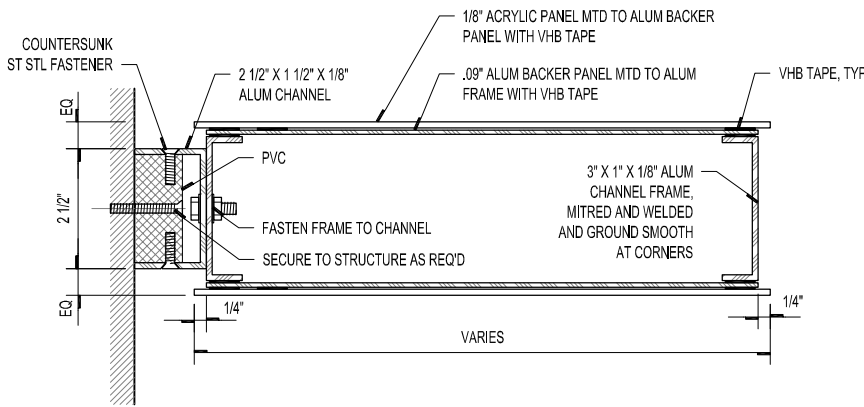

**02 SIGN BOX TYPE F-2**  
TYPICAL SECTION

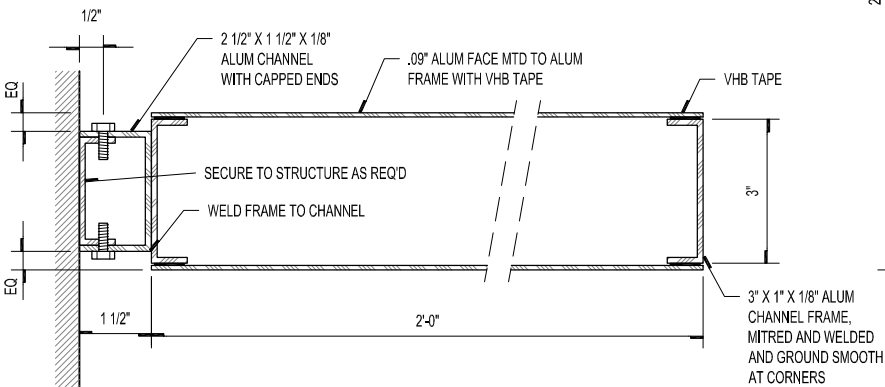

**03 SIGN BOX TYPE F-3**  
TYPICAL SECTION

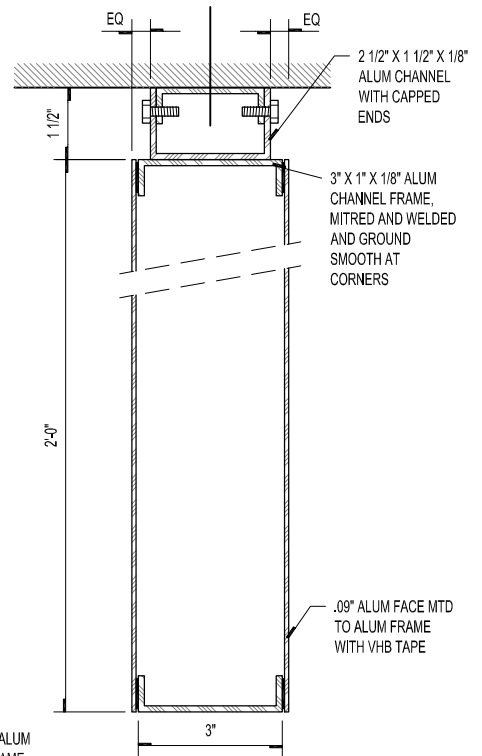

**04 SIGN BOX TYPE F-4**  
TYPICAL SECTION



Plaques Sign Box Drawings

Details for Sign Box Types G-1, G-2, and G-3

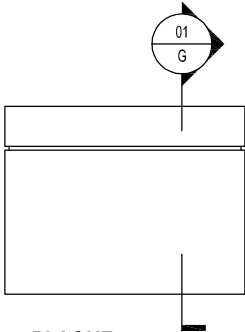

**G-1 PLAQUE**  
SIGN BOX TYPE  
NOTE: SEE SECTION 5 FOR SIGN DIMENSIONS

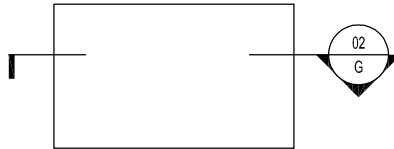

**G-2 PLAQUE**  
SIGN BOX TYPE  
NOTE: SEE SECTION 5 FOR SIGN DIMENSIONS

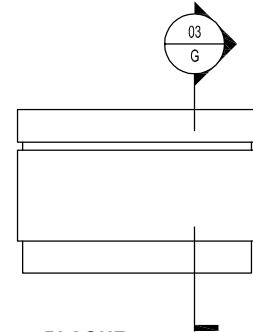

**G-3 PLAQUE**  
SIGN BOX TYPE  
NOTE: SEE SECTION 5 FOR SIGN DIMENSIONS

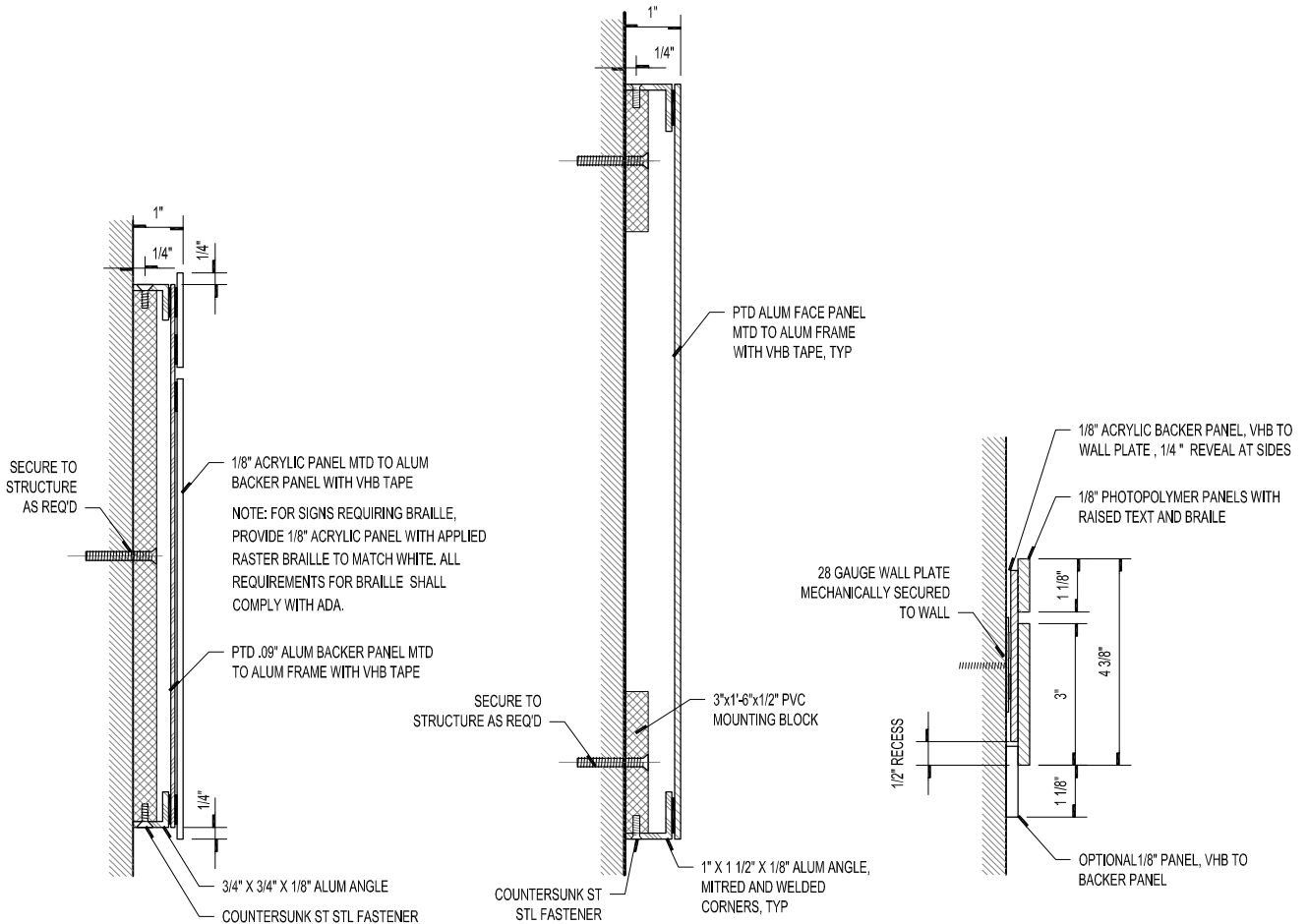

**01 SIGN BOX TYPE G-1**  
TYPICAL SECTION

**02 SIGN BOX TYPE G-2**  
TYPICAL SECTION

**03 SIGN BOX TYPE G-3**  
TYPICAL SECTION

## Specialty Sign Boxes (Sign Type S)

### Usage and Application

Specialty Sign Boxes are used with the following sign applications:

#### Primary Messages

- Identification
- Directional
- Informational

#### Secondary Messages

- Identification
- Directional
- Informational

### Methodology

Specialty Sign Boxes include sign boxes that are specific to their sign application.

### Sign Box Type Designation

Because these sign box types are specific to their sign application, the numerical designation for this category corresponds to the Sign Face Type designation shown in Section 5. For example, Sign Box Type S-164 is the sign box for Sign Face ST-164.

### Sign Box Types

**Sign Box Type S-164** are stainless steel pin-mounted letters used to identify the Airport's Information Booths. The pin-mounted letters (or pin letters) are individual dimensional letters that are attached to a wall surface using a stud rod and spaced off the wall to add depth to the lettering.

**Sign Box Type S-184** is an Informational Directory located at the airports' Information Booths. The directory consists of an aluminum face that is attached to an aluminum angle frame using VHB adhesive tape. The directory features an area with removable panels that allows messages to be changed easily.

### Mounting Type

Both sign box types, S-164 and S-184, are surface mounted.

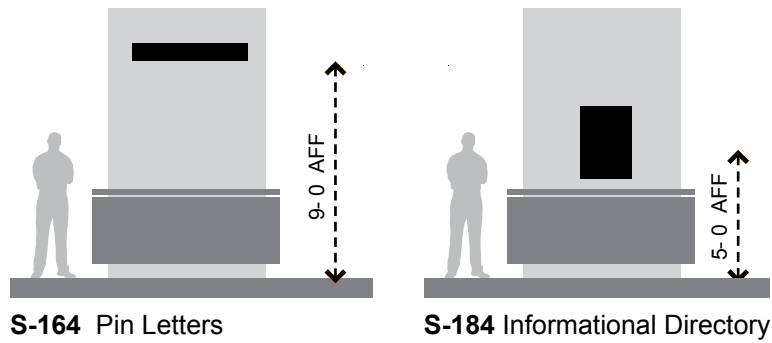

Specialty Sign Box Drawings  
 Details for Sign Box Type S-164

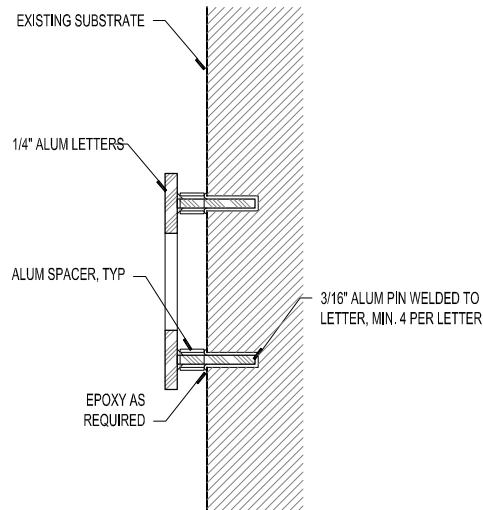
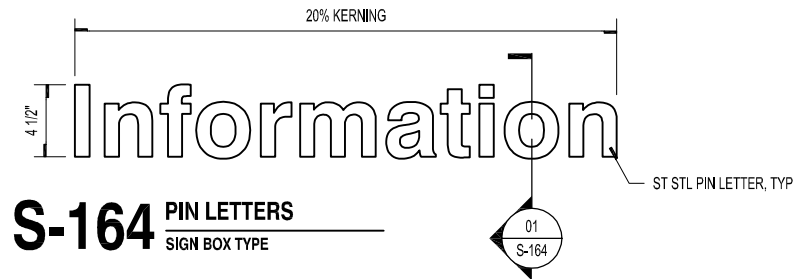

**01** SIGN BOX TYPE S-164  
TYPICAL SECTION

Details for Sign Box Type S-184

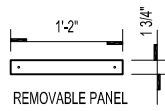
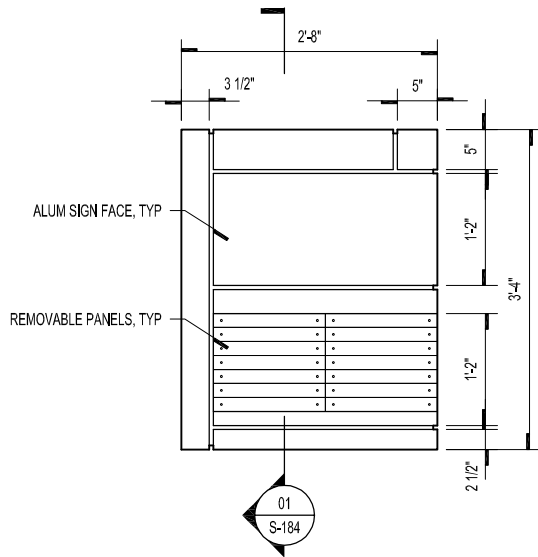

**S-184** INFORMATIONAL DIRECTORY  
SIGN BOX TYPE

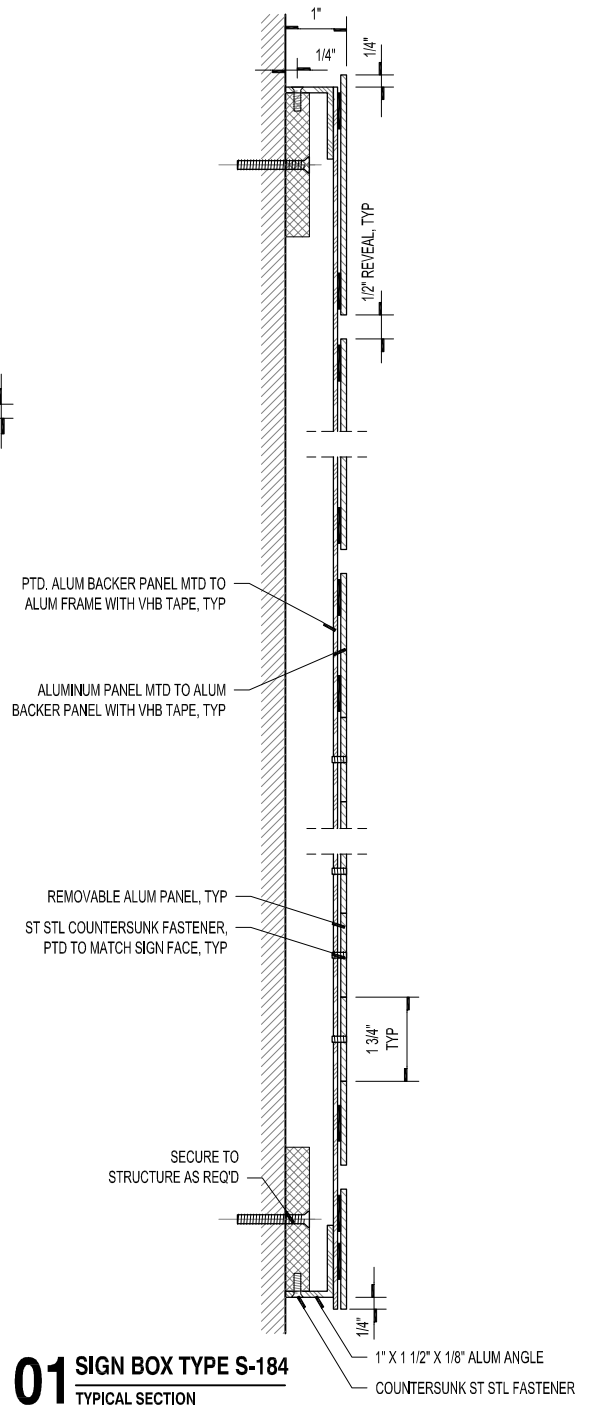

## 6.2 CURBSIDE SIGN BOXES

Sign Box Types at the Airports' Curbsides include:

### Overhead Sign Boxes

Sign Box Type A - Ceiling Mounted

Sign Box Type A-I - Ceiling Mounted - Internally Illuminated

Sign Box Type B - Soffit Mounted

### Overhead Specialty Sign Boxes

Sign Box Type D-213 - Primary Directional Airline Listing

Sign Box Type D-251 - Terminal ID - Airline Listing

Sign Box Type D-252 - Terminal ID - Airline Listing

### Over-Roadway Sign Boxes

Sign Box Type E-1 - Length up to 12'-0"

Sign Box Type E-2 - Length up to 18'-0"

### Column Wrap Sign Boxes

Sign Box Type H - Column Wrap

### Specialty Sign Boxes

Sign Box Type S-281- Ground Mounted Directory

*The drawings shown in this section are available for digital download by clicking on the link on each drawing.*

## Overhead Sign Boxes (Sign Types A and B)

### Usage and Application

Overhead Sign Boxes are used for the majority of wayfinding signs located throughout the airport. They are designed to be easily customized to accommodate any message length or location. Overhead Sign Boxes are used with the following sign applications:

#### Primary Messages

- Identification
- Directional
- Informational

#### Secondary Messages

- Identification
- Directional
- Informational

### Methodology

Overhead Sign Boxes use standard aluminum extrusions that are reinforced with bent aluminum forks. The material of the sign face for these sign boxes is acrylic. The detailing of the sign boxes vary depending on length of the sign box, method of mounting the sign box, and whether or not the sign box is illuminated.

### Mounting Types

There are two ways these sign boxes are mounted:

**Mount Type A** is suspended from the ceiling.

**Mount Type B** is attached to a soffit or a wall.

The mount type changes the internal reinforcing of the sign box independent of the length of the sign box.

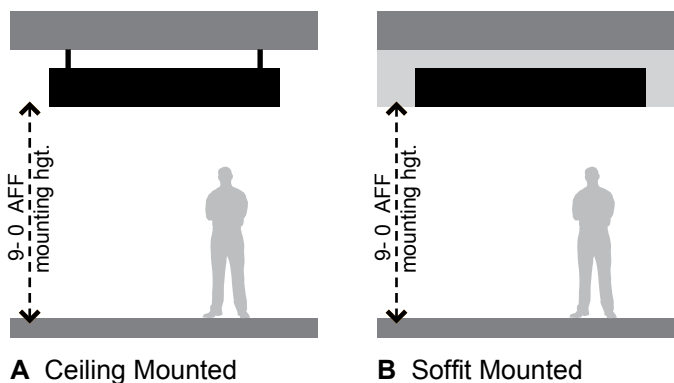

**Length Types**

There are three length types for these sign boxes:

**Length Type 1** is up to 6 feet in length.

**Length Type 2** is from 6 feet to 12 feet in length.

**Length Type 3** is from 12 feet to 18 feet in length.

The height of the sign box is independent of the sign type. All sign box types can accommodate up to 3 lines of messaging and a header. Heights beyond 3'-0" and lengths beyond the table below are considered custom.

Length Type	12	3
Header (when applicable)		
One Line Sign		
Two Line Sign		
Three Line Sign		
Sign Length	6 ft.	12 ft. 18 ft.

**Illumination**

All overhead sign boxes can be internally illuminated if desired. Illumination and lighting details vary with the length of the box and whether or not the sign box is double sided. Depending on the technology at the time of fabrication, a larger extrusion may need to be used to increase the distance between the LEDs and the sign face to avoid hot spots. A lighting diagram is provided for Sign Box Type A and is shown for a double sided internally illuminated sign, but the same concept can be applied to a single sided internally illuminated sign, or Box Type B.

**Sign Box Type Designation**

The Sign Box Type designation for Overhead Sign Boxes are a combination of Mount Type, Length Type, and whether or not the sign box is illuminated.

**Mount Type - Length Type - Illumination**





Illuminated sign boxes are given an “I” to indicate the box has illumination details. Non illuminated sign boxes receive no designation and are either lit through ambient light or direct external illumination.

An example of a 12-foot, 2-line illuminated sign box that is suspended from the ceiling is Sign Box Type A-2-I. The “A” denotes a suspended ceiling mounting, the “2” denotes a 12-foot-long sign box, and “I” denotes illumination. This nomenclature should appear in the contract documents.

Overhead Sign Box Drawings

Details for Sign Box Types A-1, A-2, and A-3 (Ceiling Mounted)

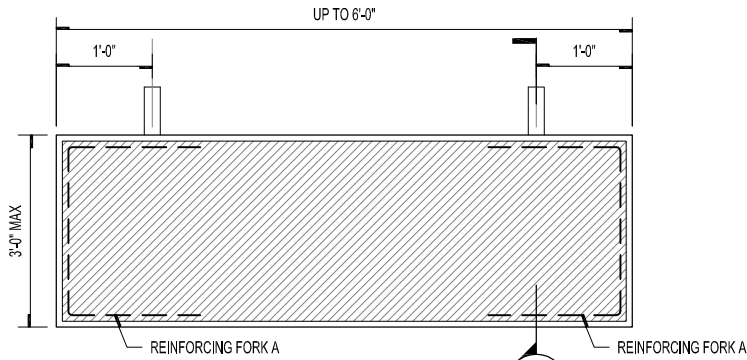

NOTE: SEE REINFORCING DETAILS FOR REINFORCING TYPES AND EXTRUSION DETAILS FOR EXTRUSION TYPES.

**A-1** OVERHEAD CEILING MOUNTED  
SIGN BOX TYPE

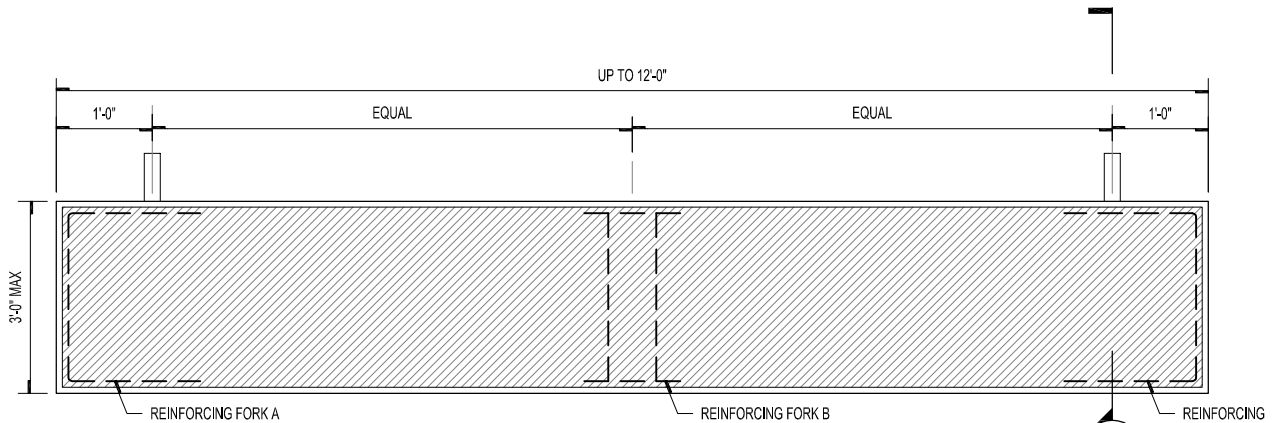

**A-2** OVERHEAD CEILING MOUNTED  
SIGN BOX TYPE

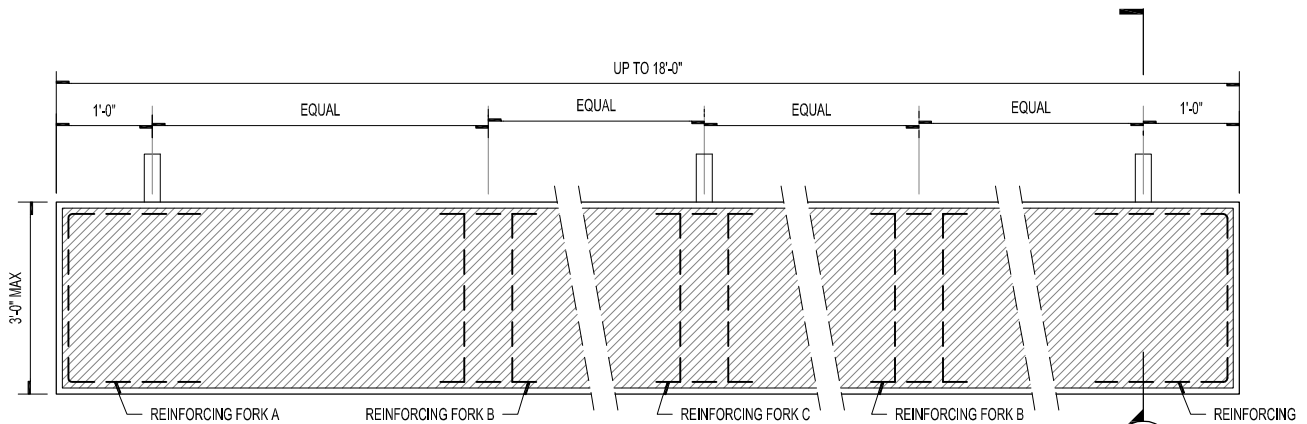

**A-3** OVERHEAD CEILING MOUNTED  
SIGN BOX TYPE



Fabrication Details for Sign Box Types A-1, A-2, and A-3

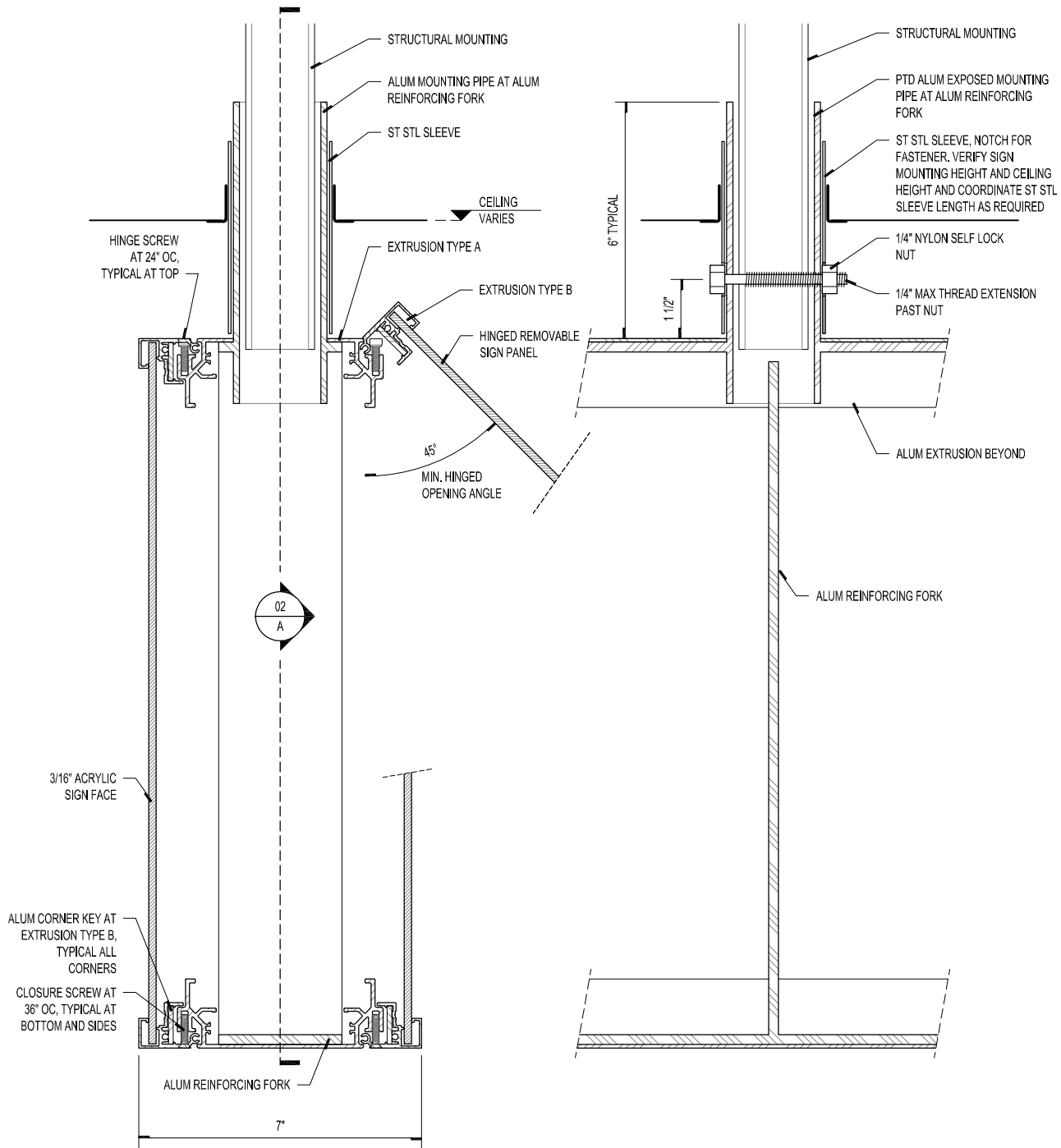

**01** SIGN BOX TYPES A-1, A-2, AND A-3  
TYPICAL SECTION

**02** SIGN BOX TYPES A-1, A-2, AND A-3  
TYPICAL SECTION

Lighting Diagram for Sign Box Types A-1-I, A-2-I, and A-3-I

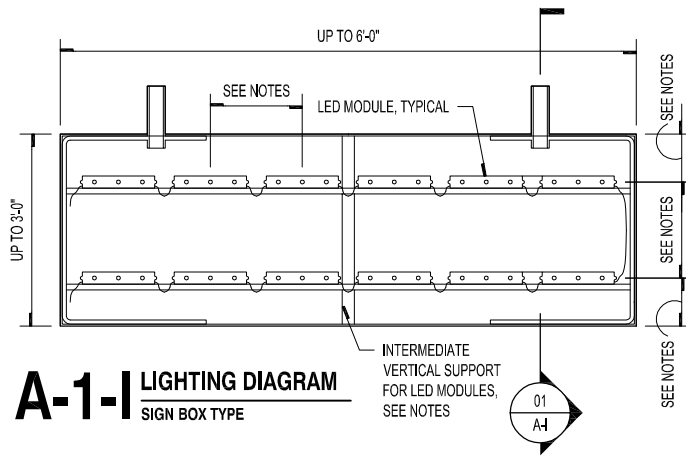

**A-1-I LIGHTING DIAGRAM**  
SIGN BOX TYPE

- NOTES:
1. LED MODULES SHOWN ON BOX TYPE A. ILLUMINATION CONCEPT APPLIES TO BOX TYPES A AND B.
  2. LAYOUT SHOWN FOR A BOX HEIGHT OF 2'-0". ADJUST NUMBER OF LED MODULES AND SPACING AS REQUIRED FOR BOX TYPES ABOVE AND BELOW 2'-0" IN HEIGHT.
  3. SPACE LED MODULES AS RECOMMENDED BY LED MODULE MANUFACTURER.
  4. PROVIDE INTERMEDIATE VERTICAL SUPPORTS EVERY 4'-0" O.C. OR AS RECOMMENDED BY LED MODULE MANUFACTURER. COORDINATE LOCATION OF SUPPORTS WITH LED MODULES TO PROVIDE EVEN ILLUMINATION AVOIDING SHADOWS AND HOT SPOTS.
  5. SEE REINFORCING DETAILS FOR REINFORCING TYPES AND EXTRUSION DETAILS FOR EXTRUSION TYPES.

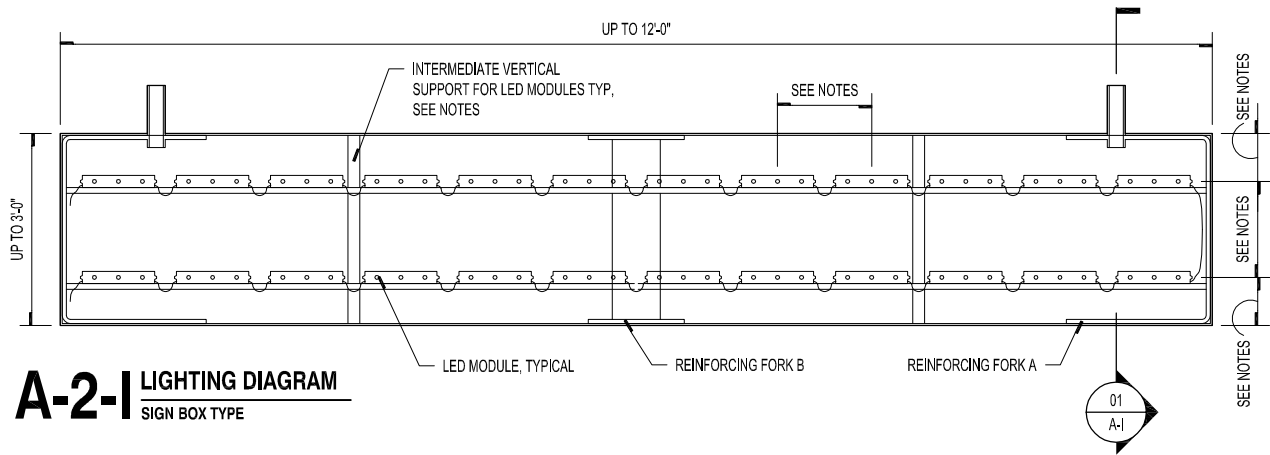

**A-2-I LIGHTING DIAGRAM**  
SIGN BOX TYPE

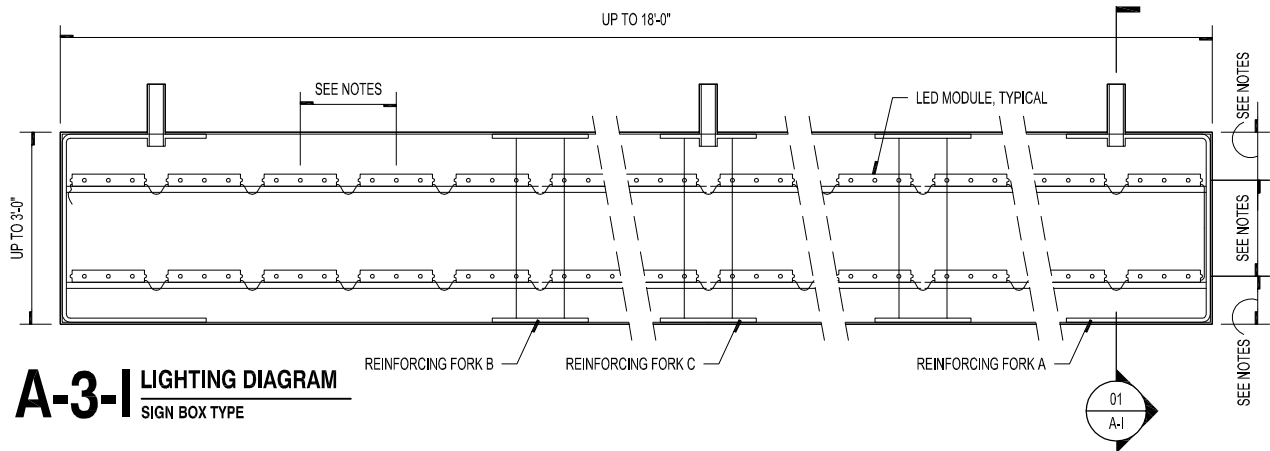

**A-3-I LIGHTING DIAGRAM**  
SIGN BOX TYPE

Fabrication Details for Sign Box Types A-1-I, A-2-I, and A-3-I (Ceiling Mounted)

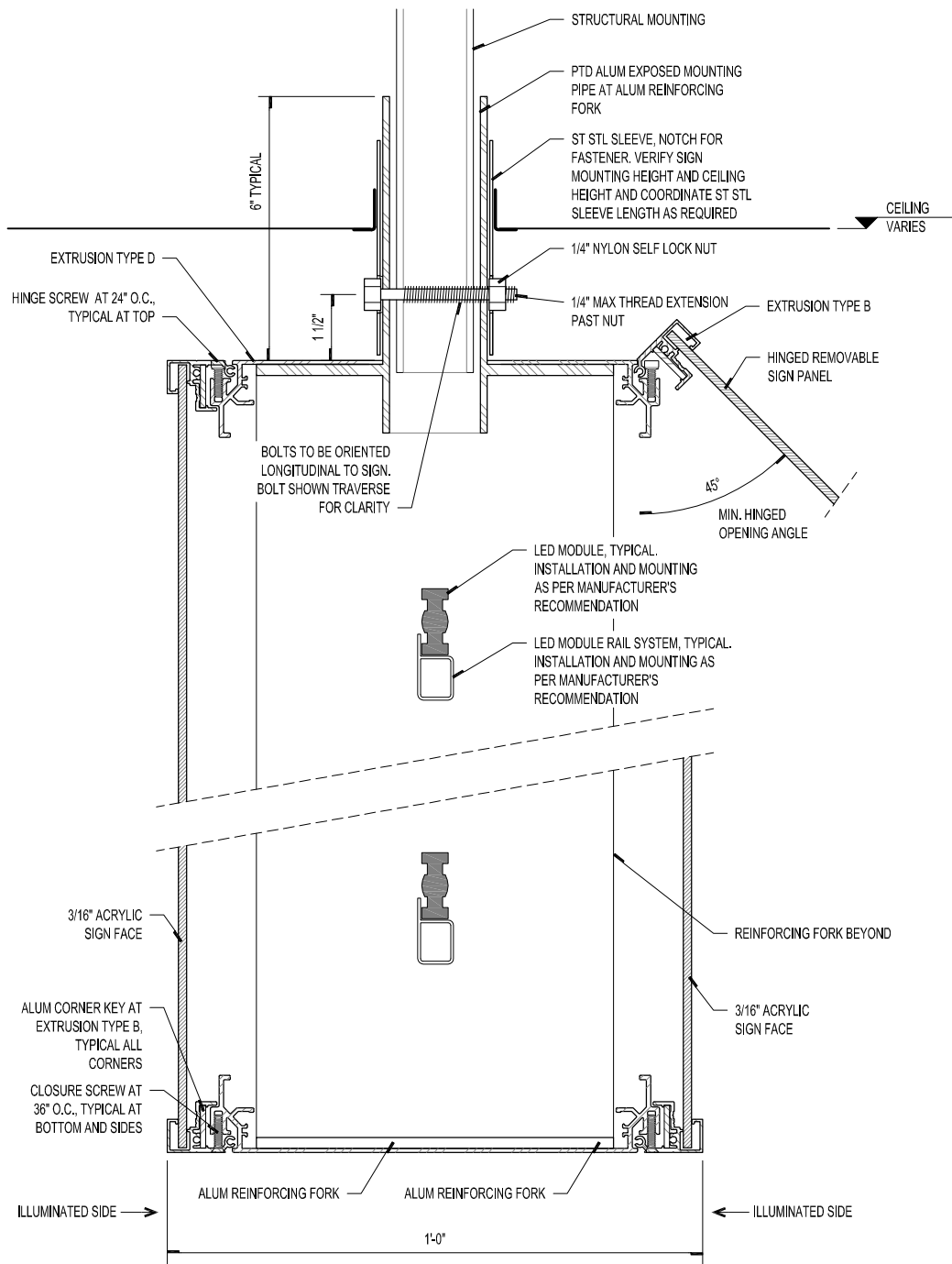

**01** SIGN BOX TYPE A-1-I, A-2-I, AND A-3-I  
TYPICAL SECTION

Details for Sign Box Types B-1, B-2, and B-3 (Soffit Mounted)

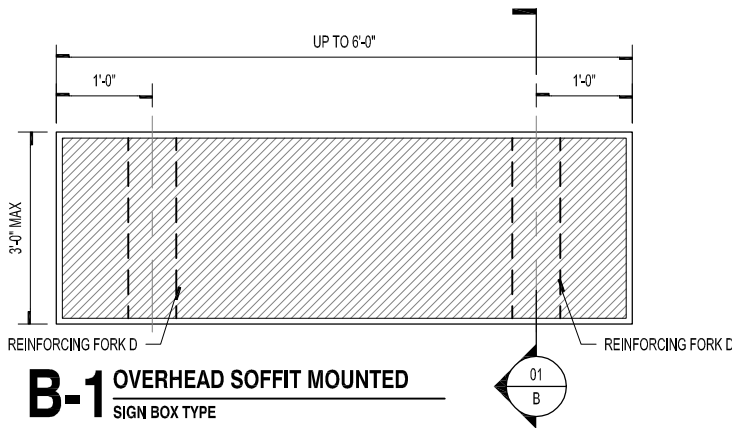

NOTE: SEE REINFORCING DETAILS FOR REINFORCING TYPES AND EXTRUSION DETAILS FOR EXTRUSION TYPES.

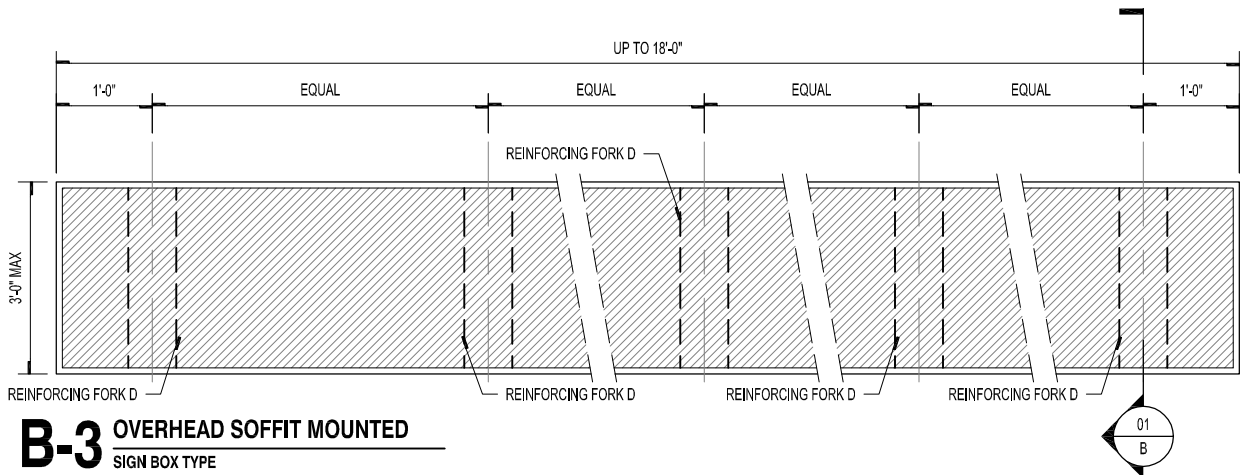
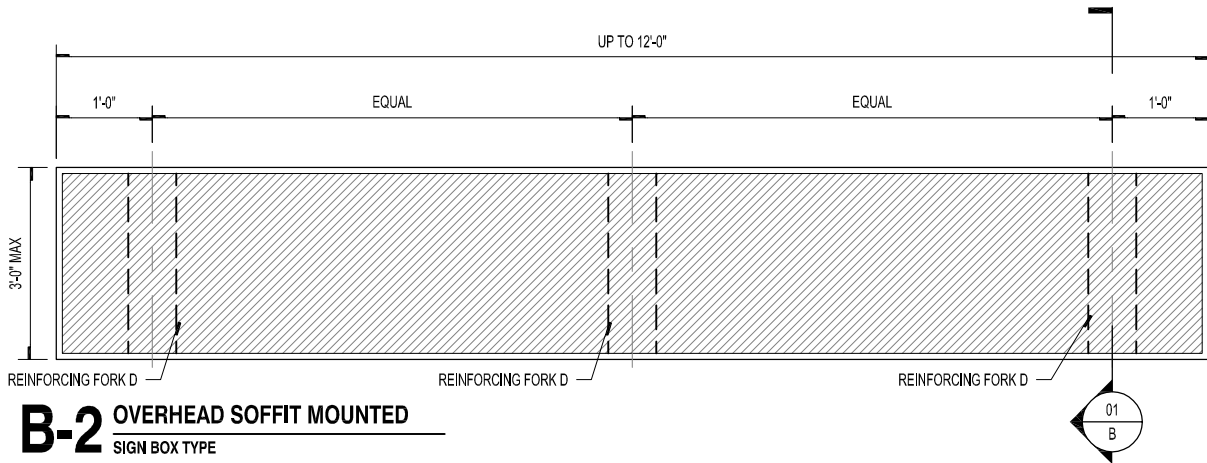

**Fabrication Details for Sign Box Types B-1, B-2, and B-3**

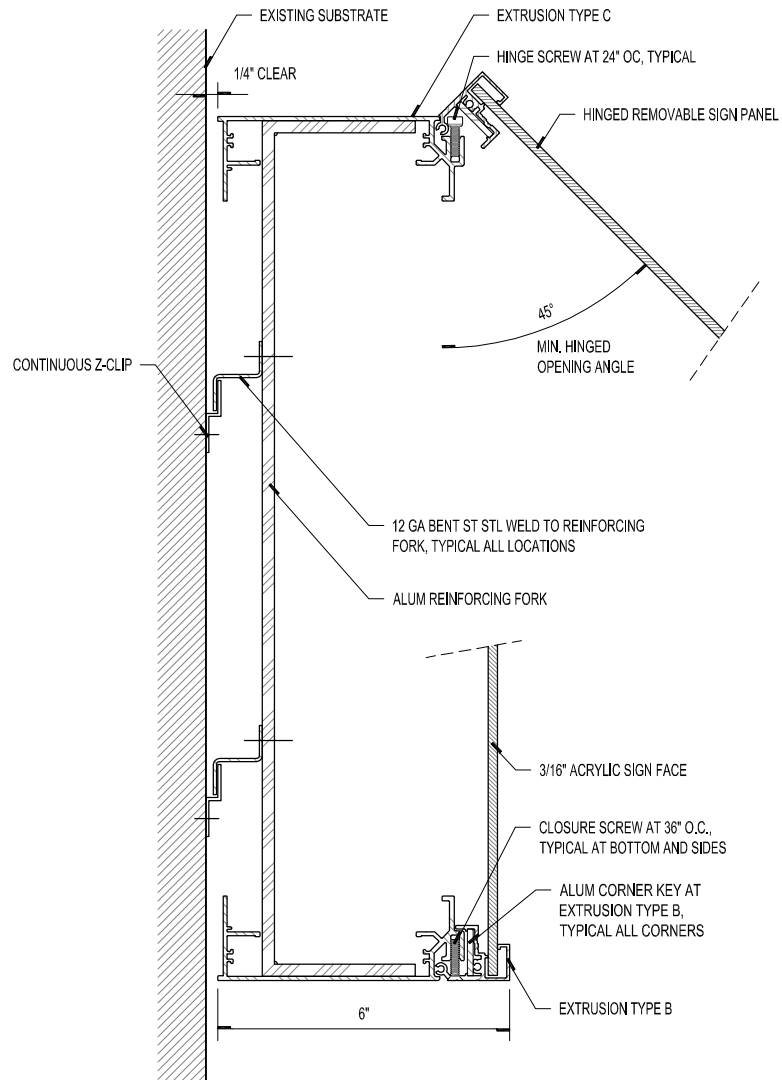

**01** SIGN BOX TYPES B-1, B-2, AND B-3  
TYPICAL SECTION

Reinforcing Details for Overhead Sign Boxes

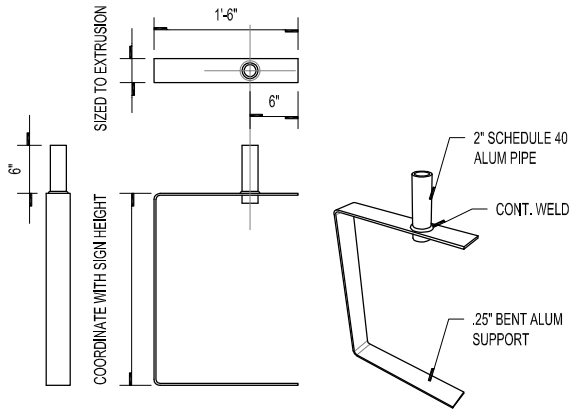

**01** REINFORCING FORK A

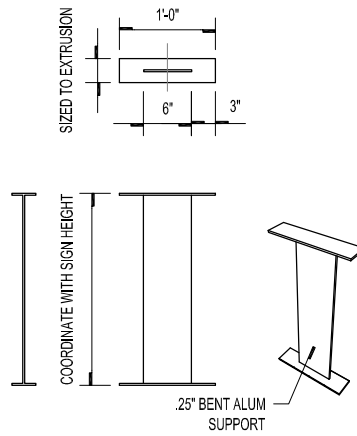

**02** REINFORCING FORK B

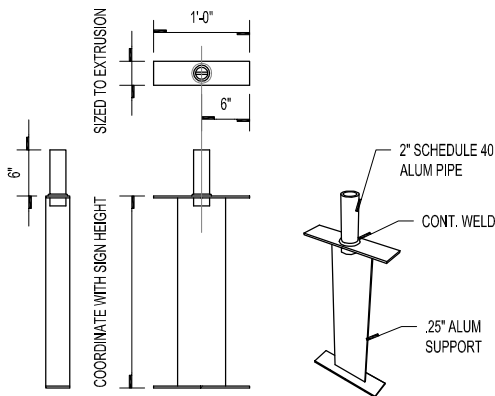

**03** REINFORCING FORK C

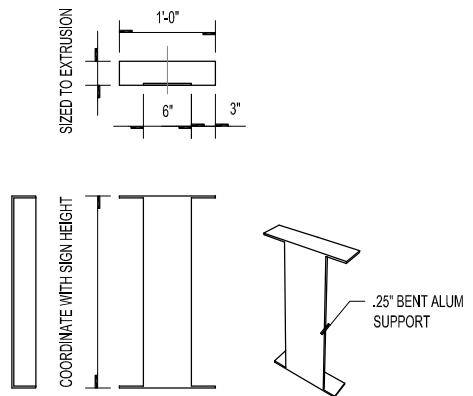

**04** REINFORCING FORK D



Extrusion Types for Overhead Sign Boxes

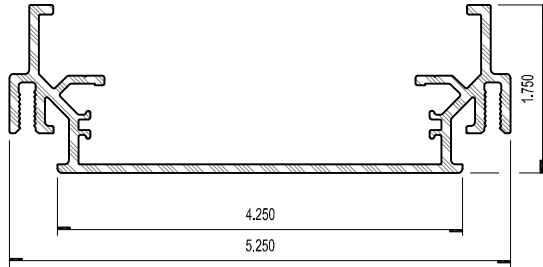

**01** EXTRUSION TYPE A  
SIGNCOMP SERIES 7

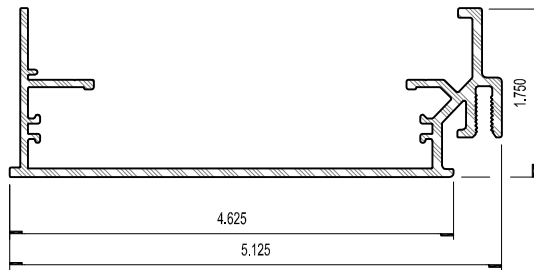

**02** EXTRUSION TYPE C  
SIGNCOMP SERIES 7

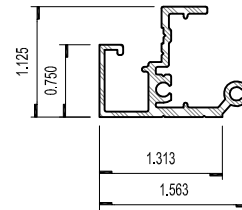

**03** EXTRUSION TYPE B  
SIGNCOMP SERIES 7

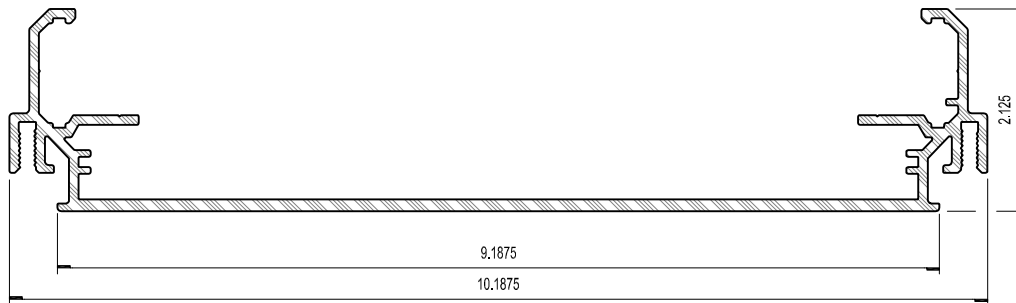

**04** EXTRUSION TYPE D  
SIGNCOMP SERIES 12 - HINGE BODY

## Overhead Specialty Sign Boxes (Sign Type D)

### Usage and Application

Overhead Specialty Sign Boxes are used with the following sign applications:

Primary Messages	Secondary Messages
<input checked="" type="checkbox"/> Identification	<input checked="" type="checkbox"/> Identification
<input checked="" type="checkbox"/> Directional	<input checked="" type="checkbox"/> Directional
<input checked="" type="checkbox"/> Informational	<input type="checkbox"/> Informational

### Methodology

Overhead Specialty Sign Boxes are custom sign boxes that are specific to their sign application. They are detailed using the same methodology as Sign Box Types A and B and use standard aluminum extrusions reinforced with bent aluminum forks.

Signs within this group are typically internally illuminated and include a variable message system component (VMS) either on one side, both sides, or a combination of the two. Only one condition is shown for each of these sign types, however, details can be modified using the same methodology for signs with different requirements. For example, a sign may be detailed with a VMS component on both sides, but can be modified to include a VMS component only on one side if desired. As with any sign that includes a lighting or VMS component, details may need to be modified based on the current technology available at the time of fabrication.

The details shown for these sign box types are for signs suspended from the ceiling. Because these sign box types use the same methodology as Sign Box Types A and B, any one of these signs can be modified to be surface mounted to a soffit or wall.

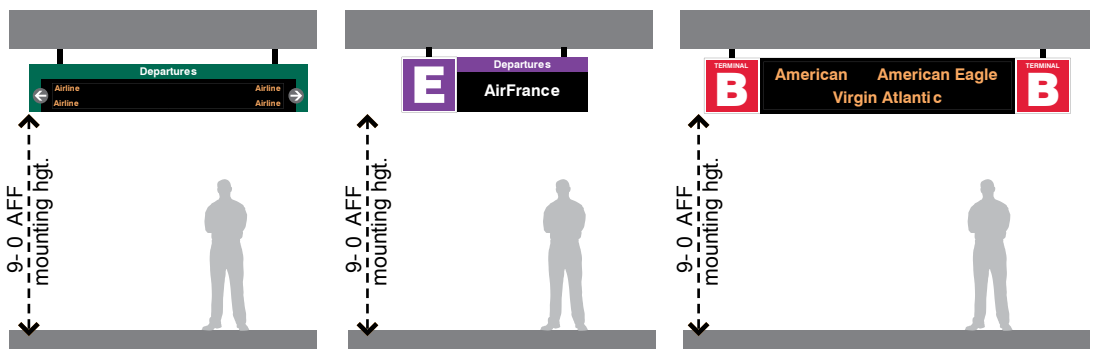

**D-213**  
Directional Airline Listing

**D-251**  
Terminal ID - Airline Listings

**D-252**  
Terminal ID - Airline Listings

### Sign Box Type Designation

Because these sign box types are specific to their sign application, the numerical designation for this category corresponds to the Sign Face Type designation shown in Section 5. For example, Sign Box Type D-213 is the sign box for Sign Face ST-213.

### Sign Box Types

**Sign Box Type D-213** is a primary directional Airline Listing Sign. This sign is non-illuminated and includes a VMS component. The details shown for this sign box type are for a double sided sign with VMS on both sides. However, the sign box can be modified using the same methodology if VMS is required only on one side or if illumination is desired. The corresponding Sign Type Application Type for this sign box type is ST-213.

**Sign Box Type D-251** is a Terminal ID - Airline Listing Sign. This sign is internally illuminated with VMS components only on one side. If required, the sign box can be modified using the same methodology to include VMS and illumination on both sides. The corresponding Sign Type Application Type for this sign box type is ST-251.

**Sign Box Type D-252** is a Terminal ID - Airline Listing Sign. This sign is internally illuminated with a VMS component. The details shown for this sign box type are for illumination and a VMS component only on one side. However, the sign box can be modified using the same methodology if VMS and illumination are required on both sides. The corresponding Sign Type Application Type for this sign box type is ST-252.

Due to the uniqueness of architecture throughout Massport's airports, there are two mounting conditions shown for this sign box type: suspended from structure above or within a storefront system.

Overhead Speciality Sign Box Drawings

Details for Sign Box Types D-213 - Directional Airline Listings Sign

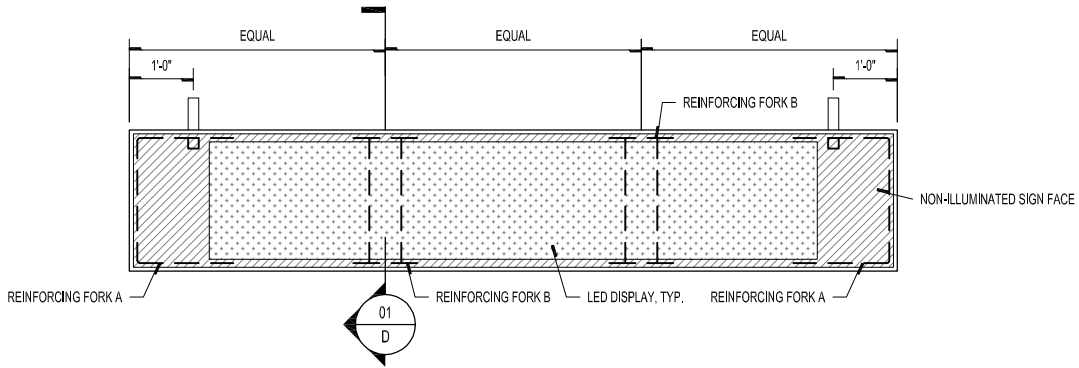

**D-213** DIRECTIONAL AIRLINE LISTING SIGN - SIDE A  
SIGN BOX TYPE - VARIABLE MESSAGE SYSTEM

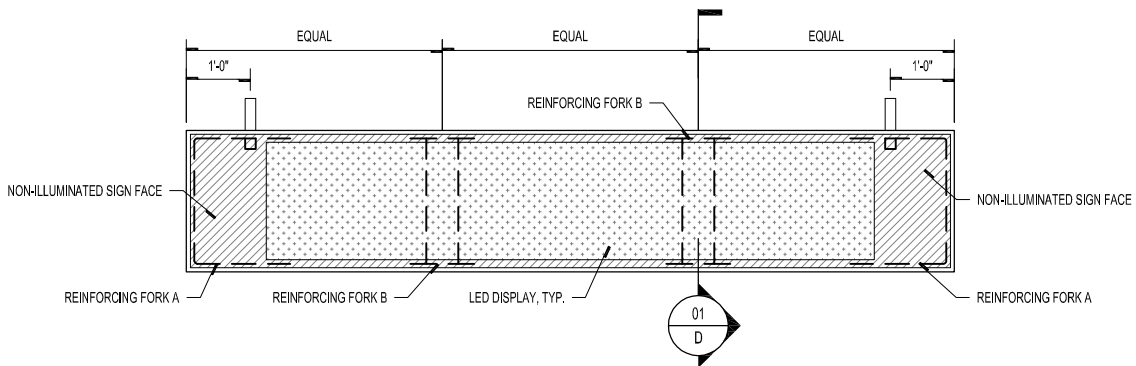

**D-213** DIRECTIONAL AIRLINE LISTING SIGN - SIDE B  
SIGN BOX TYPE - VARIABLE MESSAGE SYSTEM

**Fabrication Details for Sign Box Type D-213 - Directional Airline Listings Sign**

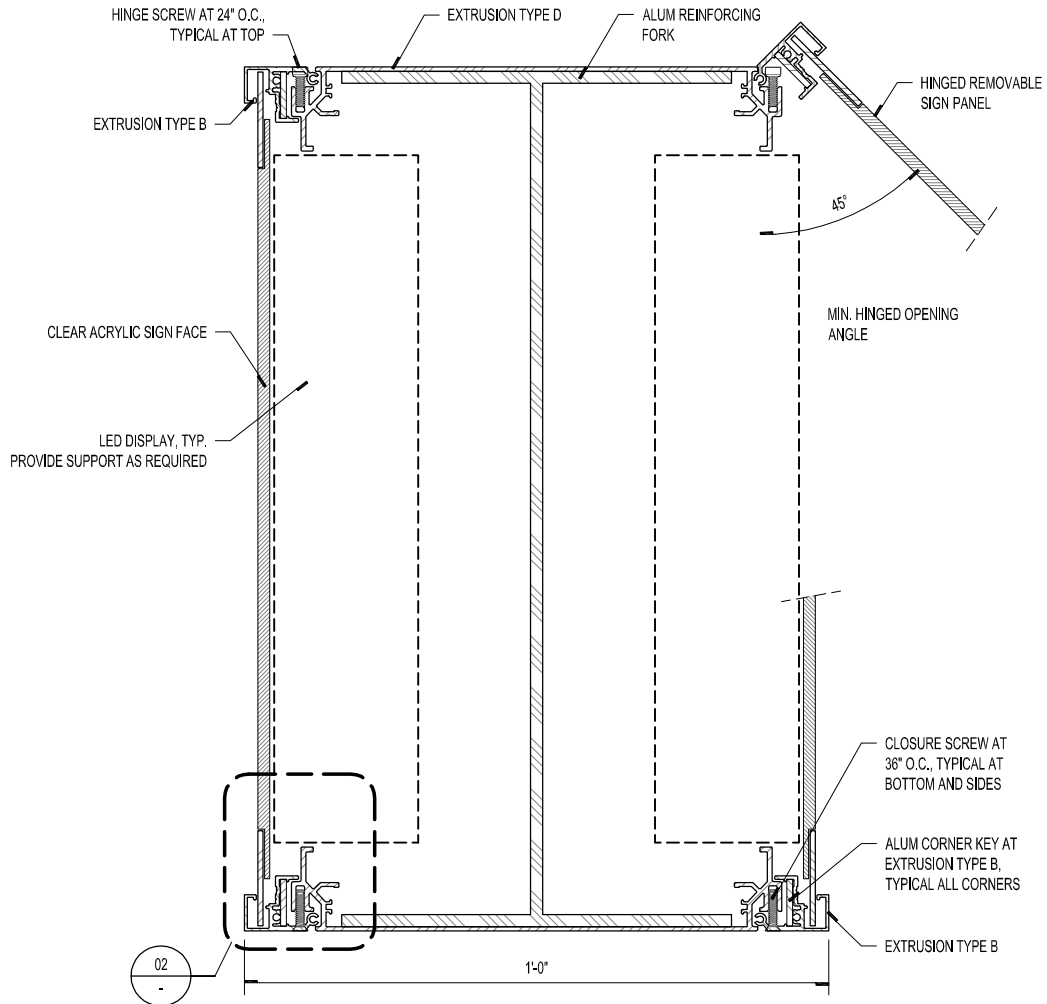

**01 SIGN BOX TYPE D AT VMS UNITS**  
TYPICAL SECTION

NOTE: PROVIDE PROP ARM TO SUPPORT HINGED SIGN PANEL DURING SERVICING, TYPICAL

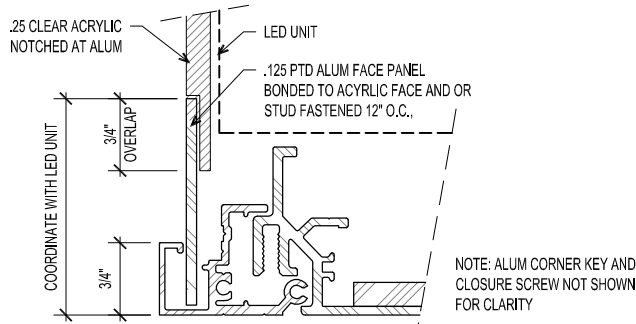

**02 SIGN FACE AT LED DISPLAY**  
TYPICAL DETAIL

Details for Sign Box Types D-251 - Terminal ID - Airline Listings Sign

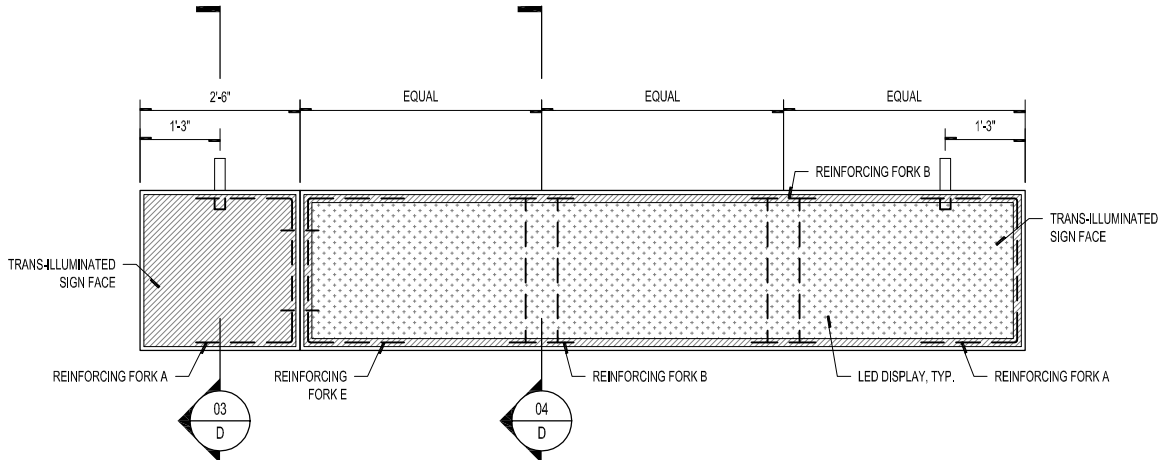

**D-251** TERMINAL ID - AIRLINE LISTING SIGN - SIDE A  
SIGN BOX TYPE - TRANS-ILLUMINATED AND LED VARIABLE MESSAGE

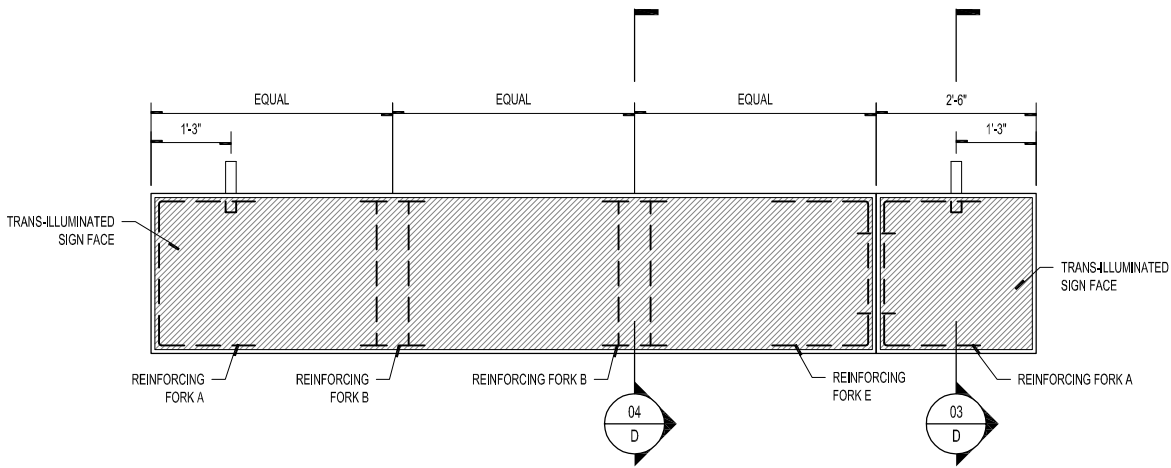

**D-251** TERMINAL ID - AIRLINE LISTING SIGN - SIDE B  
SIGN BOX TYPE - TRANS-ILLUMINATED

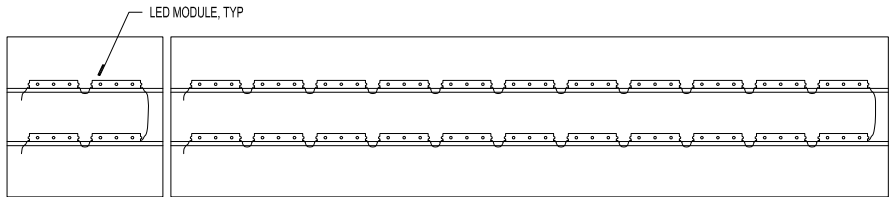

**D-251** TERMINAL ID - AIRLINE LISTING SIGN - LIGHTING DIAGRAM  
SIGN BOX TYPE

- NOTE:
1. PROVIDE SERVICE SWITCH, TYPICAL ALL POWERED SIGNS
  2. PROVIDE INTERIOR METAL RACEWAYS FOR ALL ELECTRICAL WIRING AND SIGNAL WIRING.
  3. SPACE LED MODULES AS RECOMMENDED BY LED MODULE MANUFACTURER.
  4. PROVIDE INTERMEDIATE VERTICAL SUPPORTS EVERY 4'-0" O.C. OR AS RECOMMENDED BY LED MODULE MANUFACTURER. COORDINATE LOCATION OF SUPPORTS WITH LED MODULES TO PROVIDE EVEN ILLUMINATION AVOIDING SHADOWS AND HOT SPOTS.
  5. SEE REINFORCING DETAILS FOR REINFORCING TYPES AND EXTRUSION DETAILS FOR EXTRUSION TYPES.

Fabrication Details for Sign Box Type D-251 - Terminal ID - Airline Listings Sign

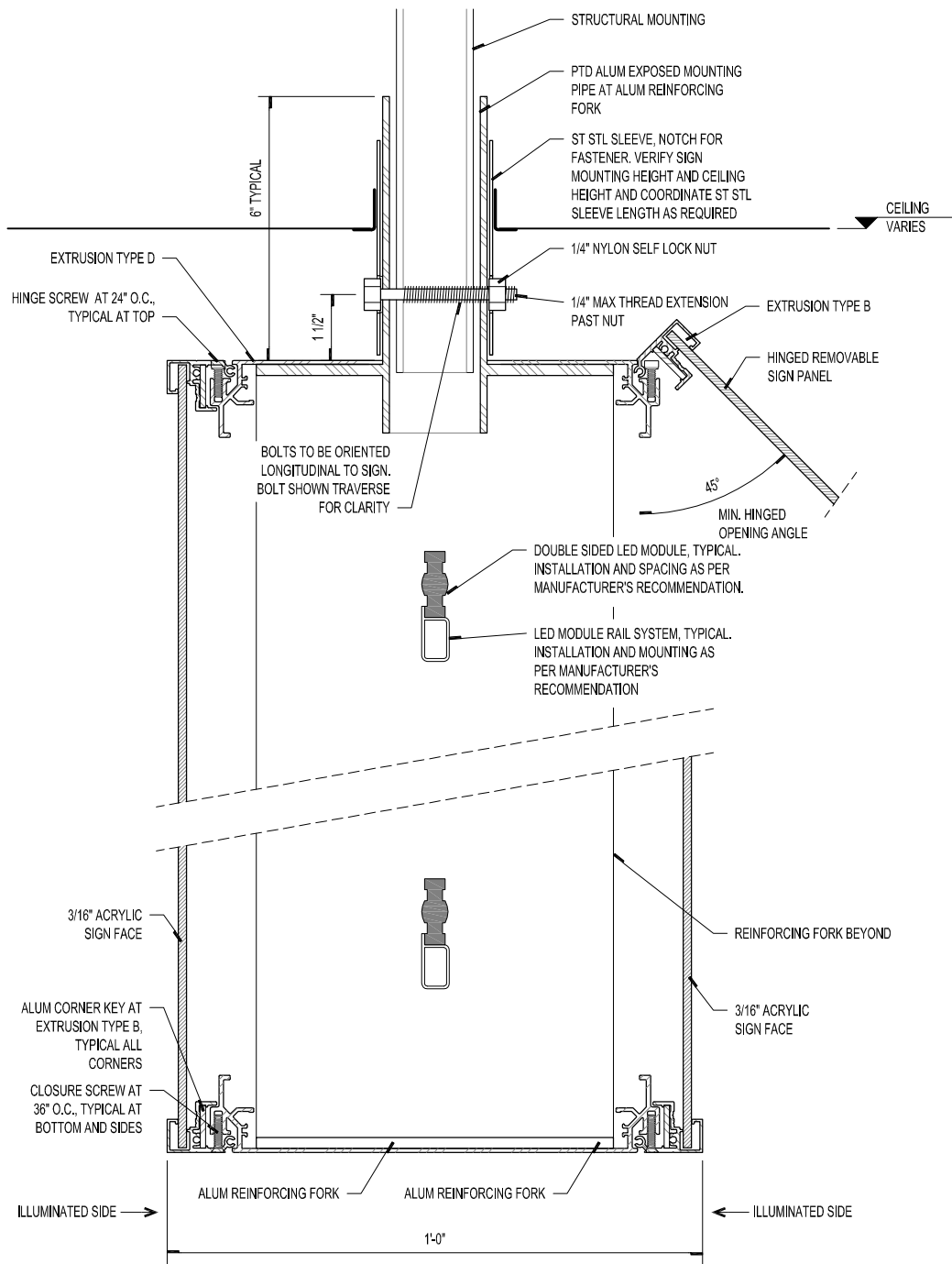

**03** SIGN BOX TYPE D AT TRANS-ILLUMINATED SIGN FACE  
TYPICAL SECTION

Fabrication Details for Sign Box Type D-251 - Terminal ID - Airline Listings Sign

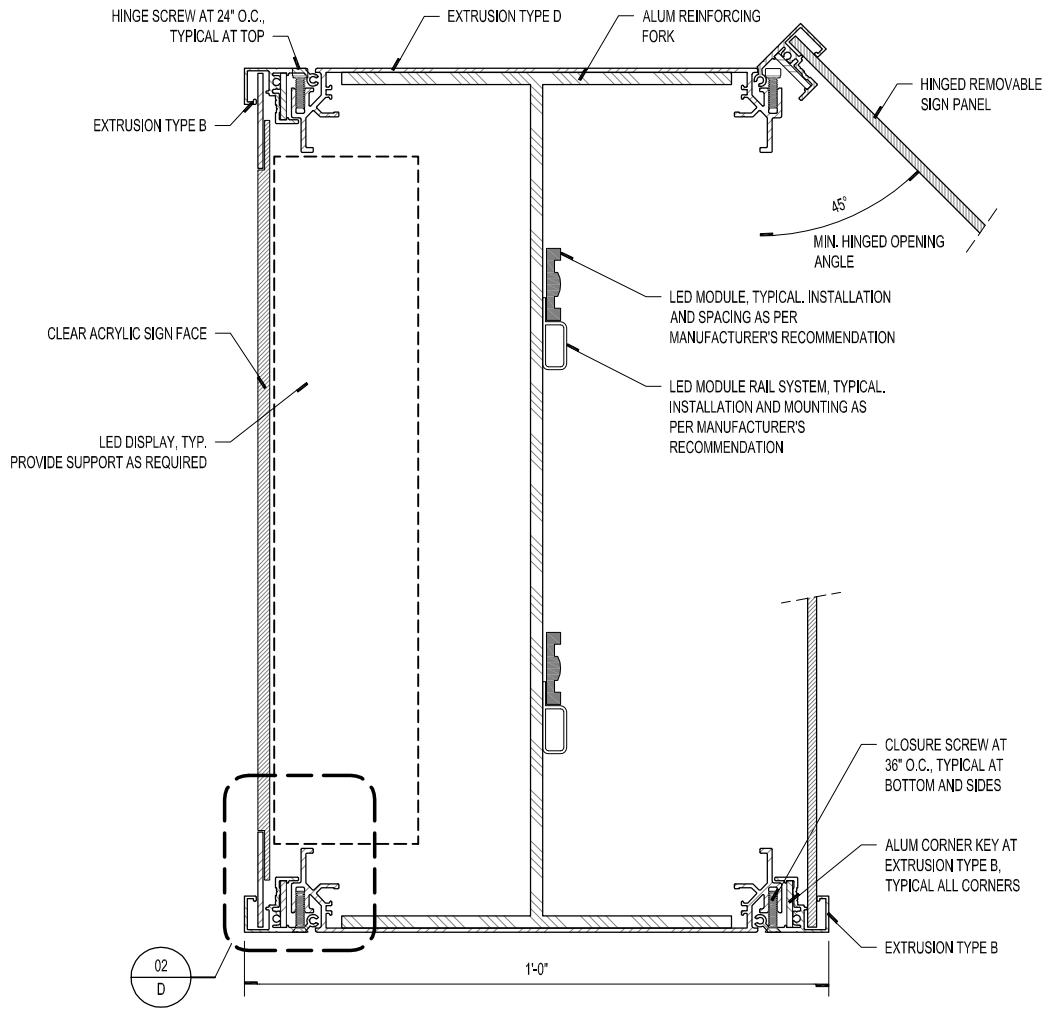

NOTE: PROVIDE PROP ARM TO SUPPORT HINGED SIGN PANEL DURING SERVICING, TYPICAL

**04** SIGN BOX TYPE D  
AT VMS UNIT AND TRANS-ILLUMINATED SIGN FACE  
TYPICAL SECTION



Details for Sign Box Types D-252 - Terminal ID - Airline Listings Sign

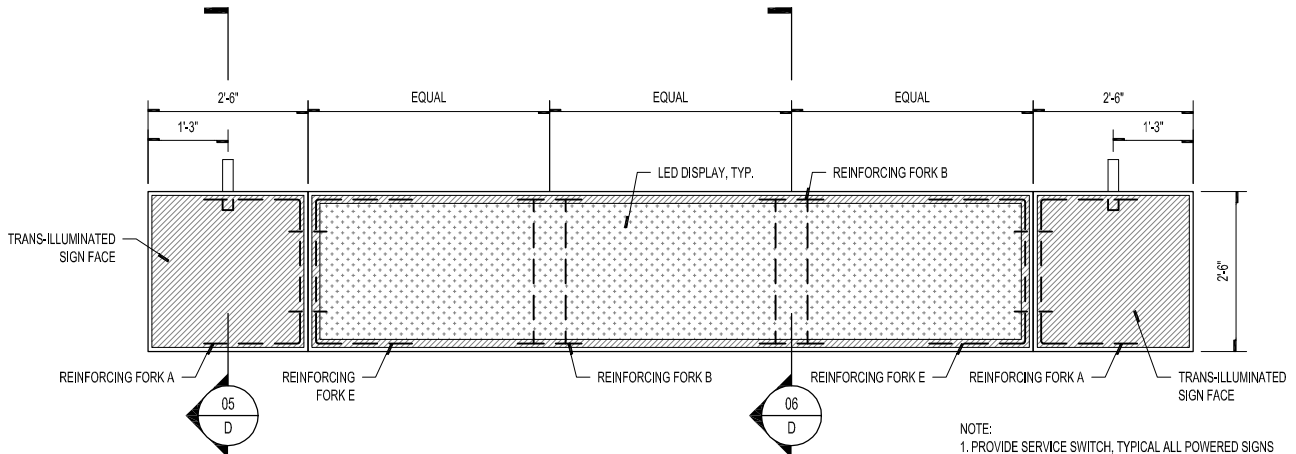

**D-252** TERMINAL ID - AIRLINE LISTINGS SIGN - SIDE A  
SIGN BOX TYPE - TRANS-ILLUMINATED AND LED VARIABLE MESSAGE

- NOTE:
1. PROVIDE SERVICE SWITCH, TYPICAL ALL POWERED SIGNS
  2. PROVIDE INTERIOR METAL RACEWAYS FOR ALL ELECTRICAL WIRING AND SIGNAL WIRING.
  3. SPACE LED MODULES AS RECOMMENDED BY LED MODULE MANUFACTURER.
  4. PROVIDE INTERMEDIATE VERTICAL SUPPORTS EVERY 4'-0" O.C. OR AS RECOMMENDED BY LED MODULE MANUFACTURER. COORDINATE LOCATION OF SUPPORTS WITH LED MODULES TO PROVIDE EVEN ILLUMINATION AVOIDING SHADOWS AND HOT SPOTS.
  5. SEE REINFORCING DETAILS FOR REINFORCING TYPES AND EXTRUSION DETAILS FOR EXTRUSION TYPES.

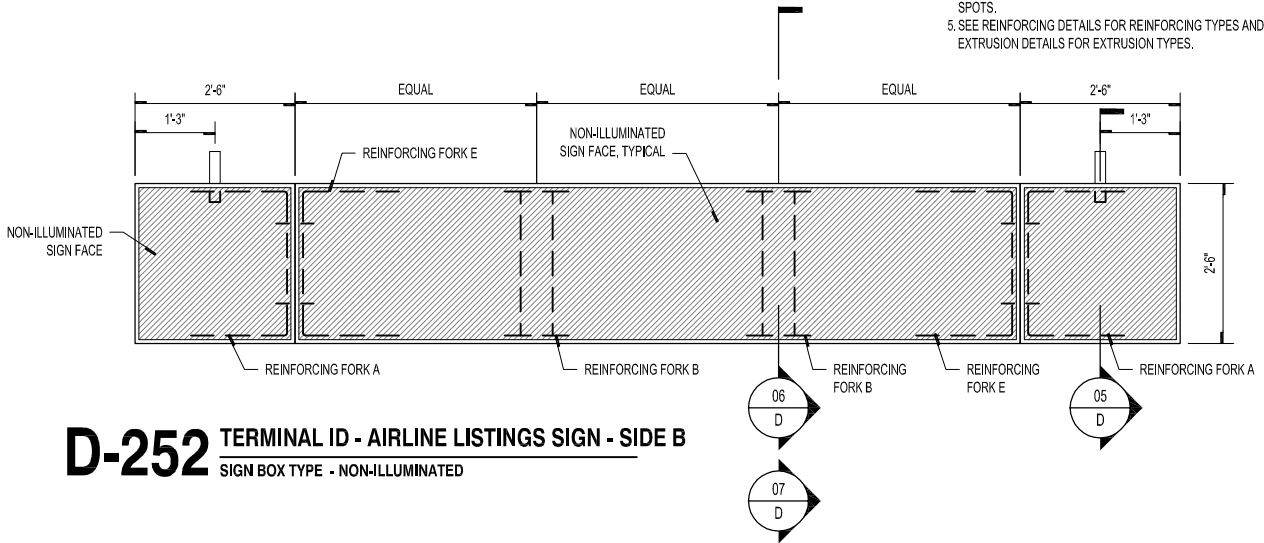

**D-252** TERMINAL ID - AIRLINE LISTINGS SIGN - SIDE B  
SIGN BOX TYPE - NON-ILLUMINATED

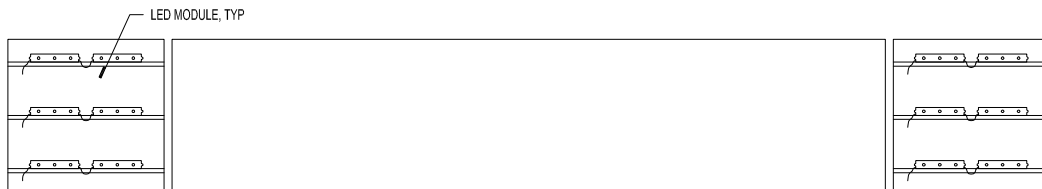

**D-252** TERMINAL ID - AIRLINE LISTINGS SIGN - LIGHTING DIAGRAM  
SIGN BOX TYPE

**Fabrication Details for Sign Box Type D-252 - Terminal ID - Airline Listings Sign (Suspended Above)**

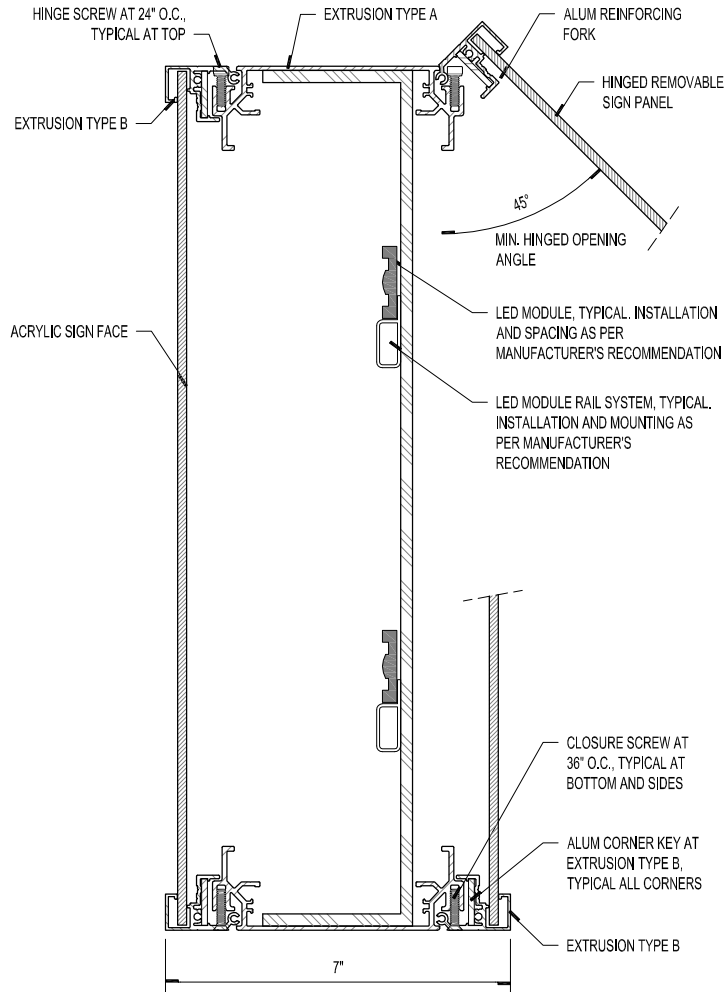

**05** SIGN BOX TYPE D AT TRANS-ILLUMINATED SIGN FACE  
TYPICAL SECTION

NOTE: PROVIDE PROP ARM TO SUPPORT HINGED SIGN PANEL DURING SERVICING, TYPICAL

**Fabrication Details for Sign Box Type D-252 - Terminal ID - Airline Listings Sign (Suspended Above)**

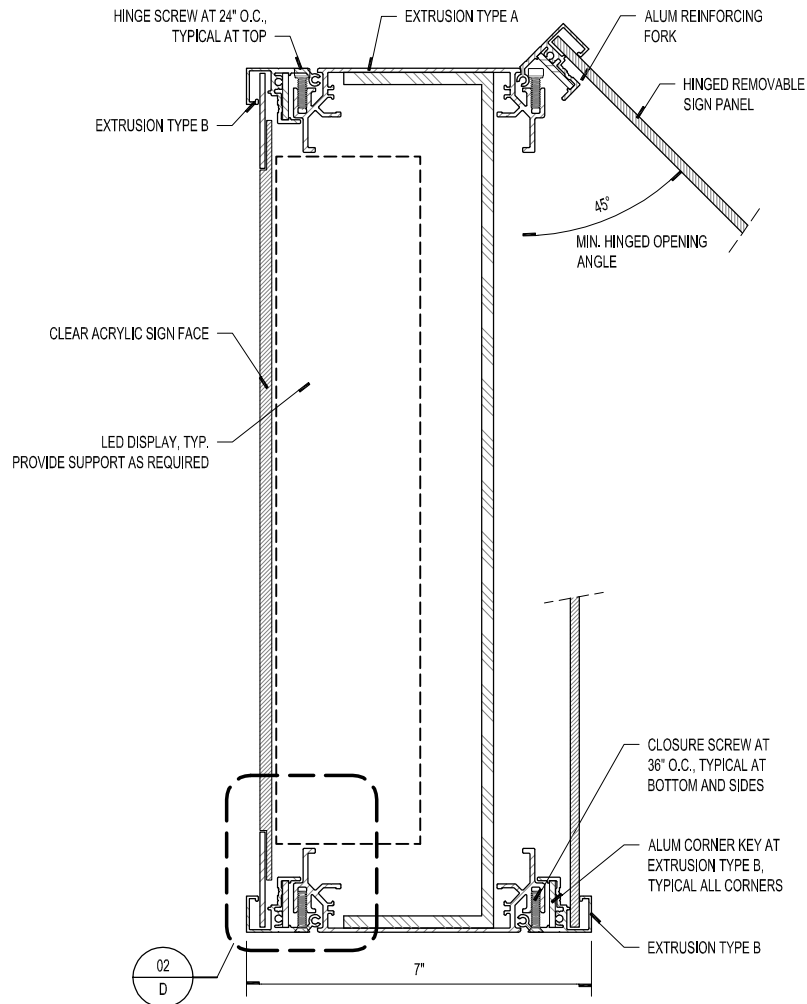

02  
D

**06** SIGN BOX TYPE D AT VMS UNIT  
TYPICAL SECTION

NOTE: PROVIDE PROP ARM TO SUPPORT HINGED SIGN PANEL DURING SERVICING, TYPICAL

**Fabrication Details for Sign Box Types D-252**  
**Terminal ID - Airline Listings Sign (Within Storefront System)**

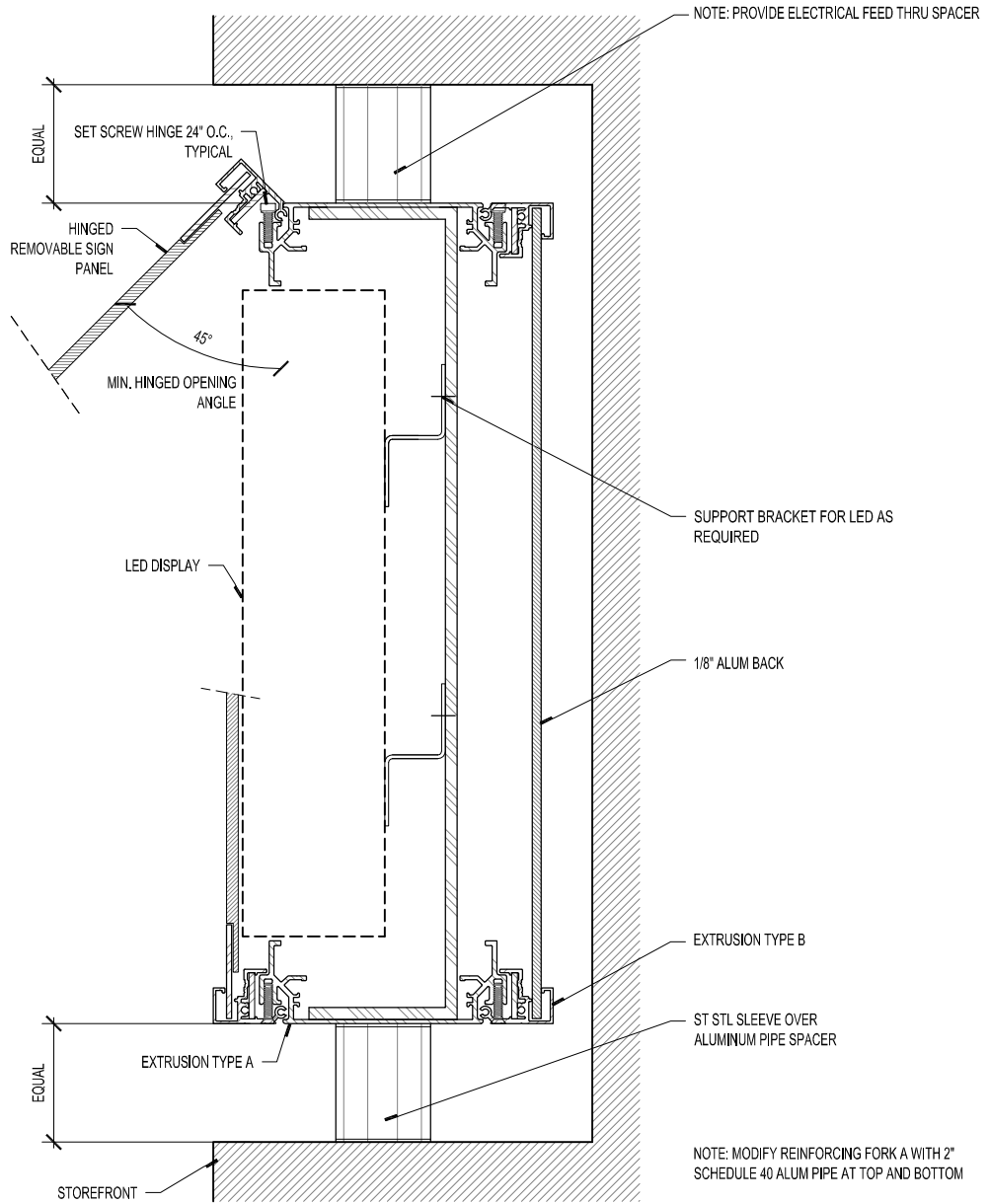

**07** SIGN BOX TYPE D AT VMS UNIT  
 TYPICAL SECTION



Reinforcing Fork Details for Overhead Specialty Sign Boxes

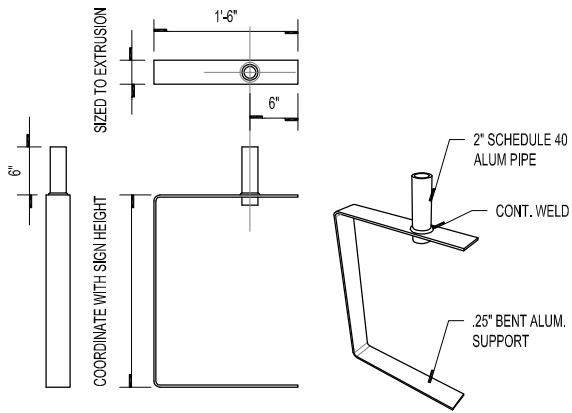

**01** REINFORCING FORK A

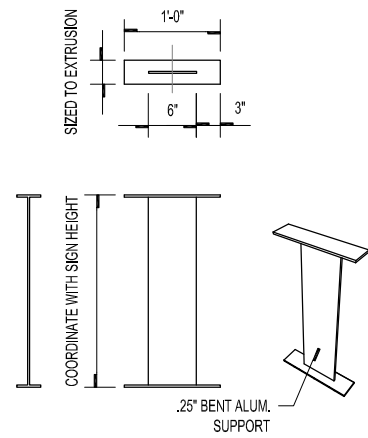

**02** REINFORCING FORK B

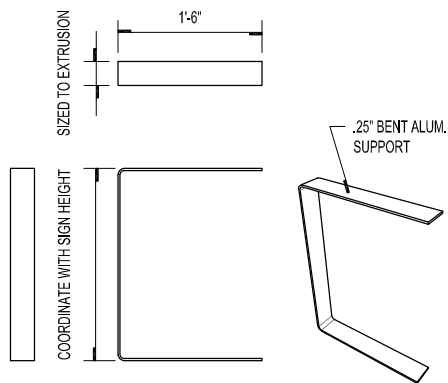

**03** REINFORCING FORK E

*Extrusion Types for Overhead Specialty Sign Boxes*

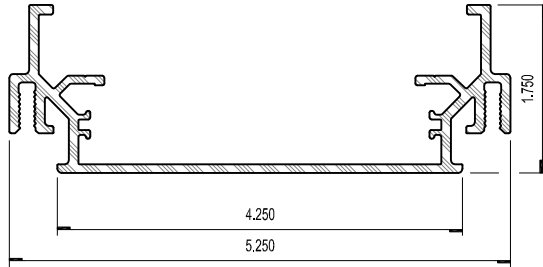

**01** EXTRUSION TYPE A  
SIGNCOMP SERIES 7

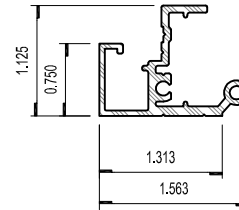

**02** EXTRUSION TYPE B  
SIGNCOMP SERIES 7

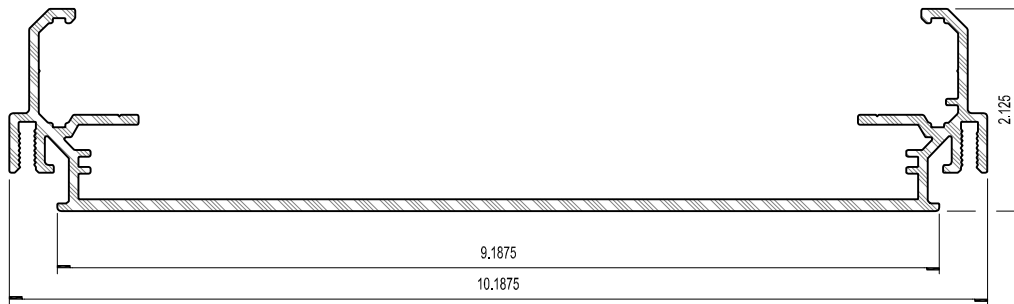

**03** EXTRUSION TYPE D  
SIGNCOMP SERIES 12 - HINGE BODY

## Over-Roadway Sign Boxes (Sign Box Type E)

### Usage and Application

Over-Roadway Sign Boxes are used for vehicular wayfinding signs located above the roadway at terminal curbsides and at select signs in parking areas. Over-Roadway Sign Boxes are used with the following sign applications:

#### Primary Messages

- Identification
- Directional
- Informational

#### Secondary Messages

- Identification
- Directional
- Informational

### Methodology

Over-Roadway Sign Boxes are detailed using an aluminum tube frame for the structure. The material of the sign face is aluminum and is attached to the frame using aluminum angles and ultra or very high bond (VHB) tape. The detailing of the sign boxes vary depending on length of the sign box.

### Sign Box Types

There are two sign box types for Over-Roadway signs based on length.

**Sign Box Type E-1** is up to 12 feet in length.

**Sign Box Type E-2** is from 12 feet to 18 feet in length.

Lengths beyond 18'-0" are considered custom. The height of the sign box is independent of the sign type, but heights above 1'-0" are also considered custom.

### Mounting Type

These sign boxes are suspended over the roadway from the structure above

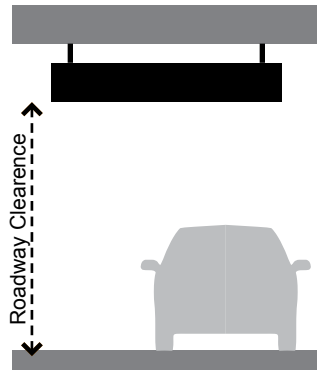

Over Roadway



**Over-Roadway Sign Box Drawings**  
*Details for Sign Box Types E-1 and E-2*

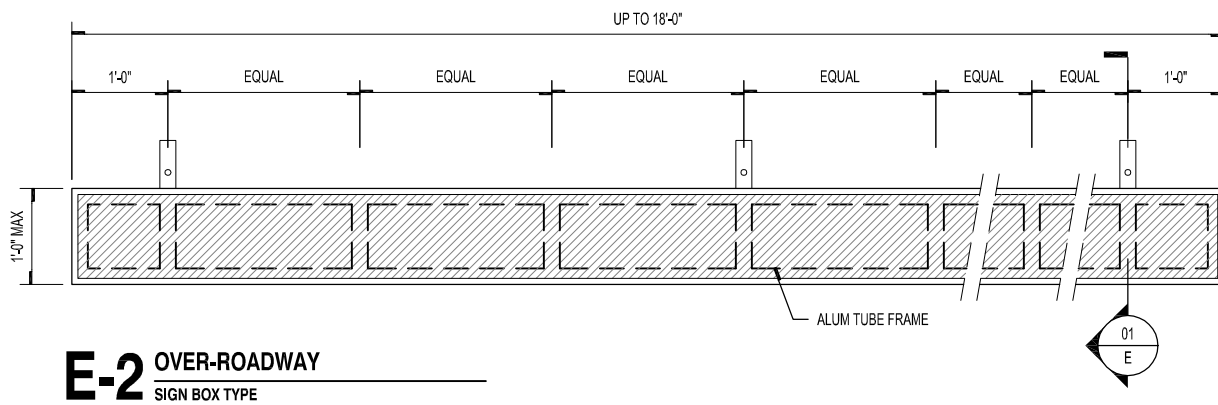
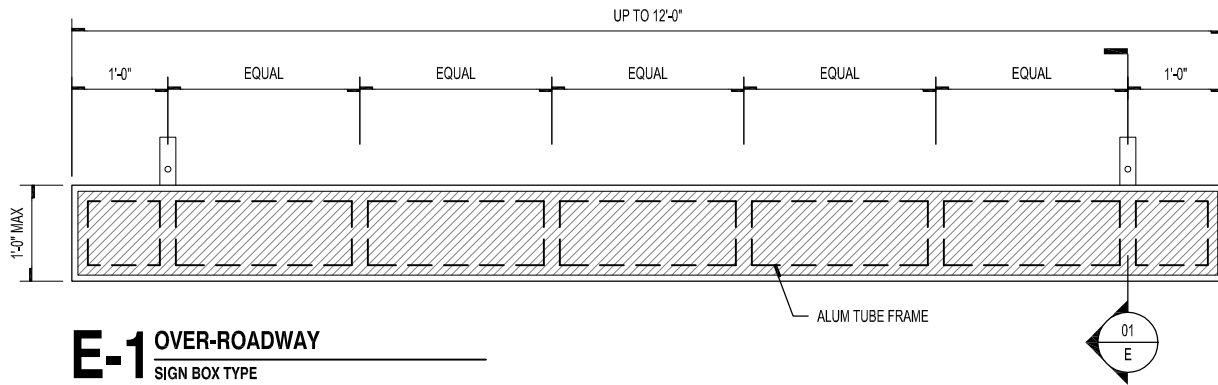

**Fabrication Details for Sign Box Types E-1 and E-2**

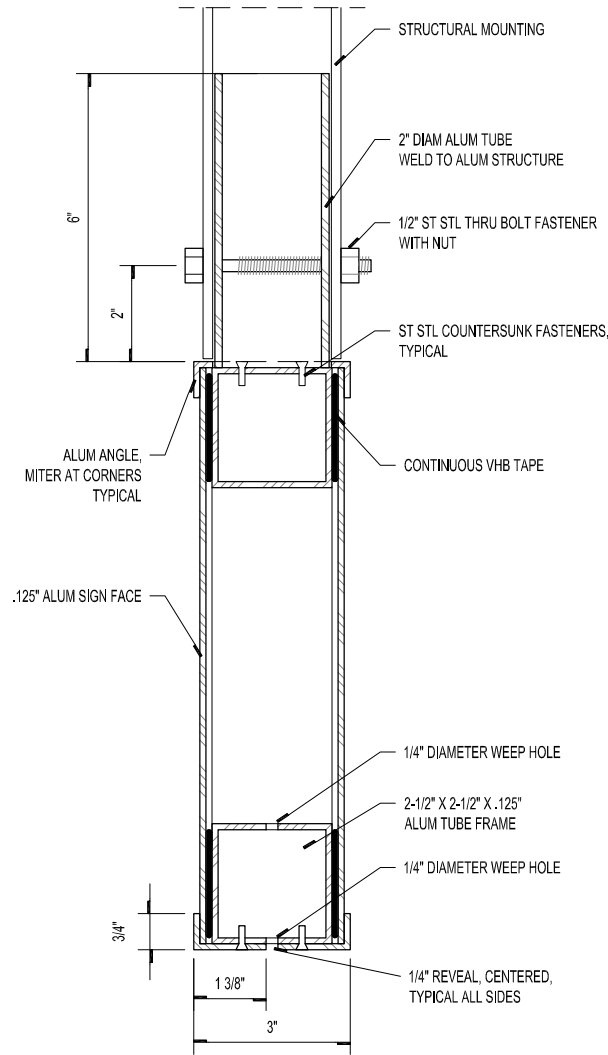

**01** SIGN BOX TYPES E-1 AND E-2  
TYPICAL SECTION

## Column Wrap Sign Box (Sign Box Type H)

### Usage and Application

Column Wrap Sign Boxes are used for vehicular and pedestrian wayfinding signs located at terminal curbsides. They are used with the following sign applications and occasionally for Tertiary Regulatory Messages.

#### Primary Messages

- Identification
- Directional
- Informational

#### Secondary Messages

- Identification
- Directional
- Informational

### Methodology

Column Wrap Sign Boxes are mounted tangent to a column and have sign faces on all four sides. They are detailed using an aluminum tube frame for the structure with an aluminum sign face. The size of the sign boxes are dependant upon the diameter of the column. Mounting conditions will vary based on the column material and/or its encasement.

### Sign Box Type Designation

There is only one sign box type for Column Wrap Signs.

**Sign Box Type H** is a 4-sided sign.

### Mounting Type

These signs are mounted to a column.

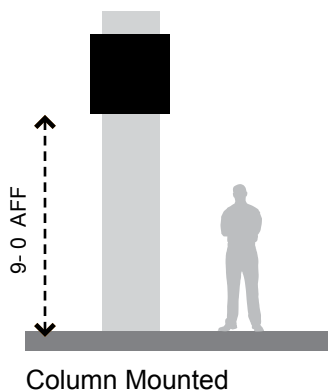

**Column Wrap Sign Box Drawings**  
**Details for Sign Box Types H**

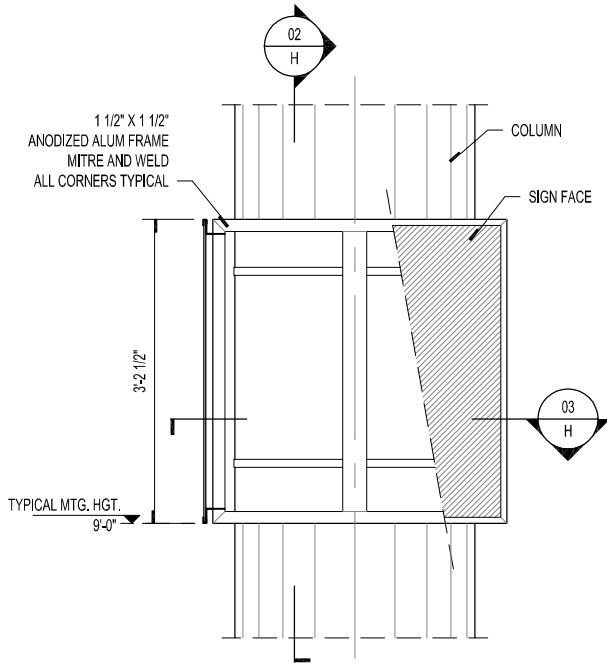

**01 SIGN BOX TYPE H**  
SIGN SECTION / ELEVATION

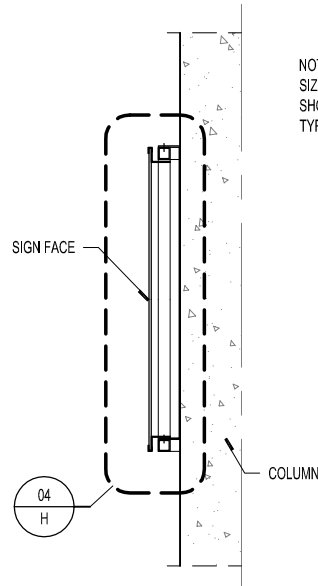

NOTE:  
 SIZE OF SIGN IS BASED ON COLUMN DIAMETER. SIZE SHOWN IS FOR A 2'-6" DIAMETER COLUMN. APPLY BOX TYPE CONCEPT AND ADJUST DIMENSIONS AS REQUIRED.

**02 SIGN BOX TYPE H**  
SIGN SECTION

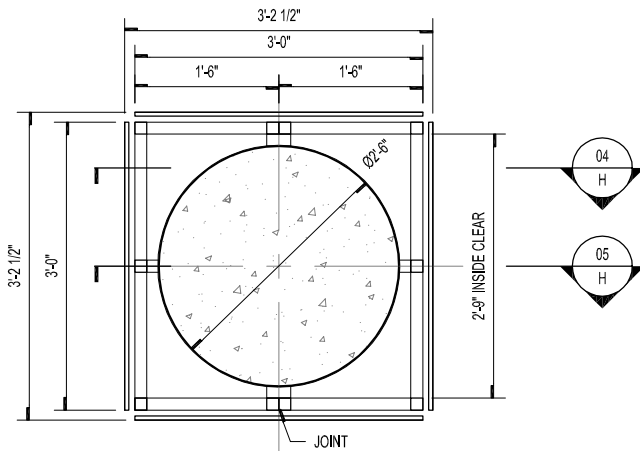

**03 SIGN BOX TYPE H**  
SIGN PLAN / SECTION

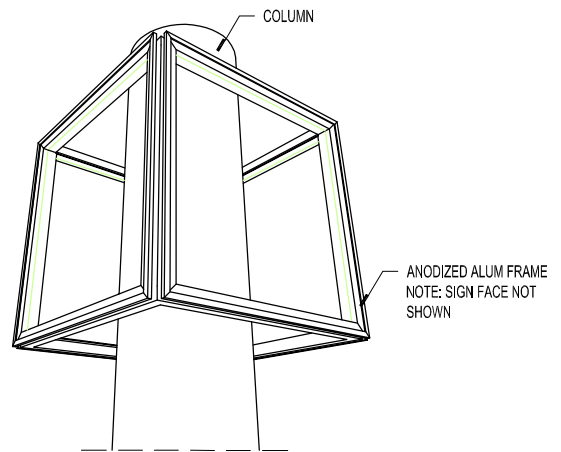

**H COLUMN WRAP SIGN**  
SIGN BOX TYPE

**Fabrication Details for Sign Box Type H - Column Wrap Signs**

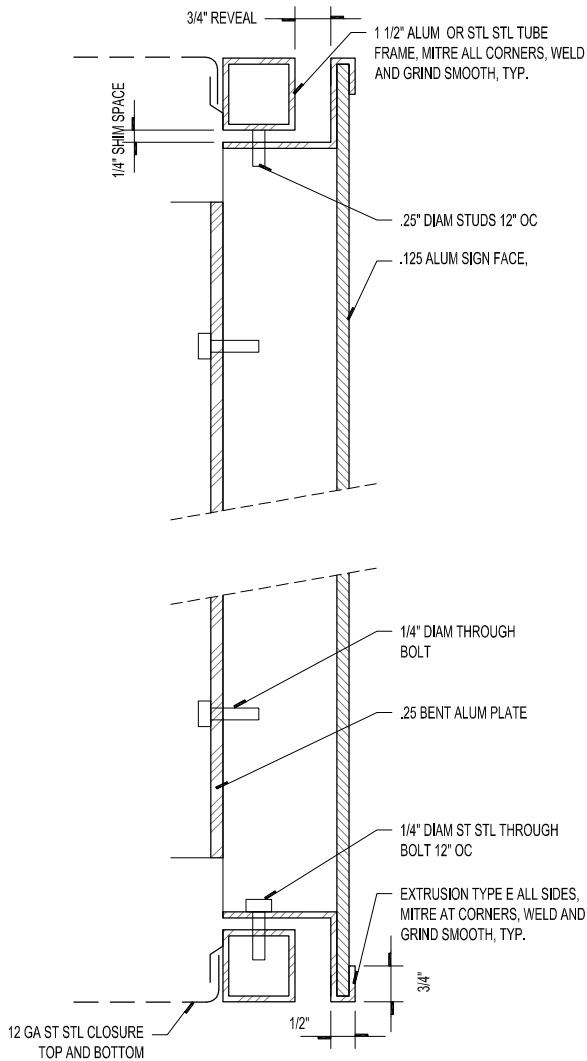

**04** SIGN BOX TYPE H  
TYPICAL SECTION

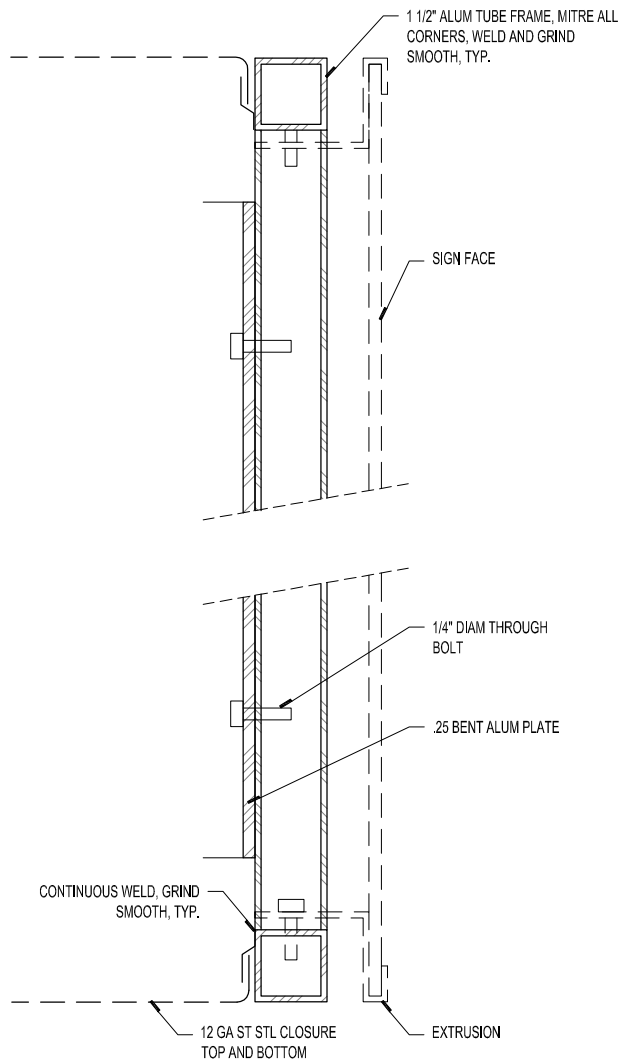

**05** SIGN BOX TYPE H  
TYPICAL SECTION - INTERNAL STRUCTURE

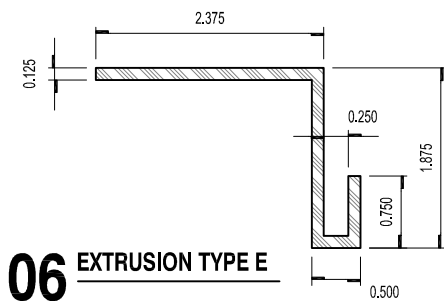

**06** EXTRUSION TYPE E

## Specialty Sign Boxes (Sign Type S)

### Usage and Application

Specialty Sign Boxes are used with the following sign applications:

#### Primary Messages

- Identification
- Directional
- Informational

#### Secondary Messages

- Identification
- Directional
- Informational

### Methodology

Specialty Sign Boxes include sign boxes that are specific to their sign application.

### Sign Box Type Designation

Because these sign box types are specific to their sign application, the numerical designation for this category corresponds to the Sign Face Type designation shown in Section 5. For example, Sign Box Type S-281 is the sign box for Sign Face ST-281.

### Sign Box Types

**Sign Box Type S-281** is a ground mounted sign box used to display Ground Transportation directory maps and information. This sign is internally illuminated with messaging on both sides.

The sign box is detailed using aluminum tubes for the internal structure of the sign that is clad with aluminum and secured to the structure using bent aluminum straps. The upper body of the sign consists of a trans-illuminated hinged sign face with an acrylic sign face and applied vinyl graphics. It features an accent vertical band to one side and a trans-illuminated header band. The header band consists of a stencil cut aluminum face with push through acrylic letters. The lower body of the sign box includes a stainless steel skirt attached to the internal structure using stainless steel Z-clips.

### Mounting Type

Sign Box Type S-281 is ground mounted.



**S-281** Ground Mounted  
Directory

Speciality Sign Box Drawings  
 Details for Sign Box Type S-281

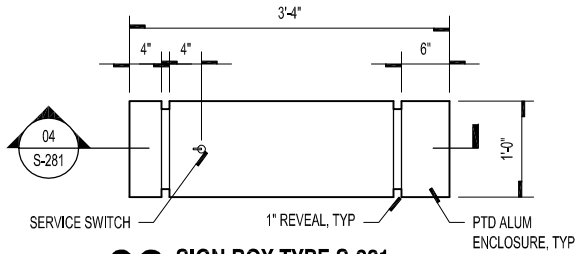

**03** SIGN BOX TYPE S-281  
 TOP ELEVATION

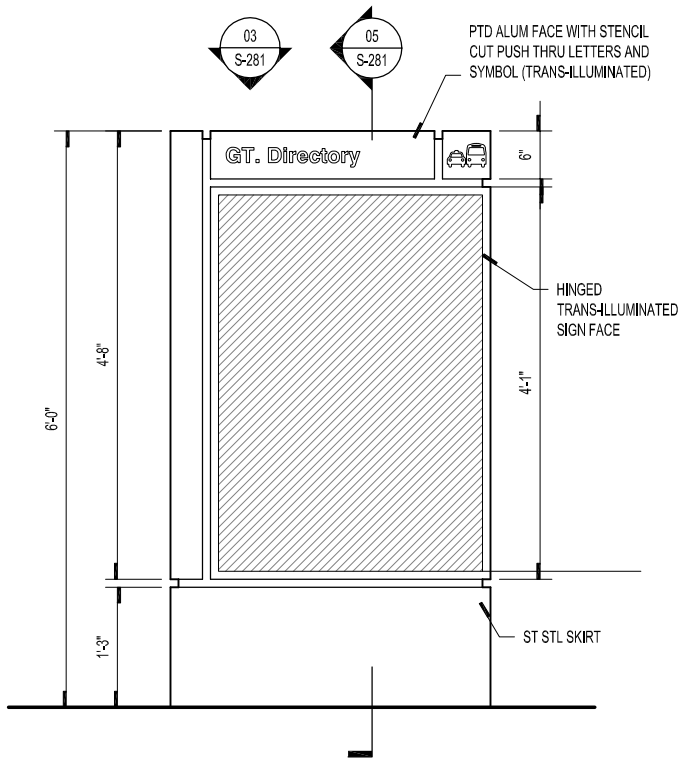

**S-281** FLOOR MOUNTED - DIRECTORY  
 SIGN BOX TYPE

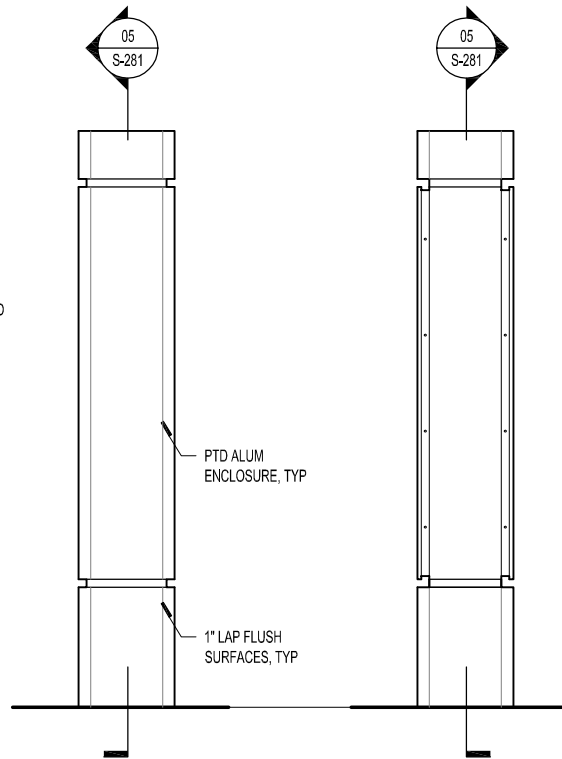

**01** SIGN BOX TYPE S-281  
 SIDE ELEVATION

**02** SIGN BOX TYPE S-281  
 SIDE ELEVATION





Details for Sign Box Type S-281

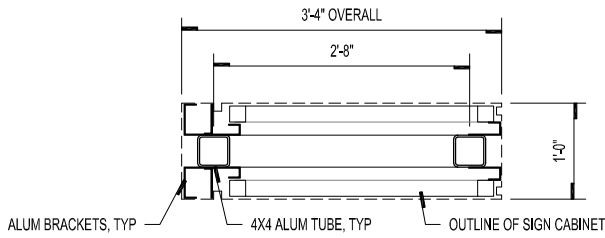

**06** SIGN BOX TYPE S-281  
INTERNAL STRUCTURE - PLAN / SECTION (SEE 11/S-281 FOR DETAIL)

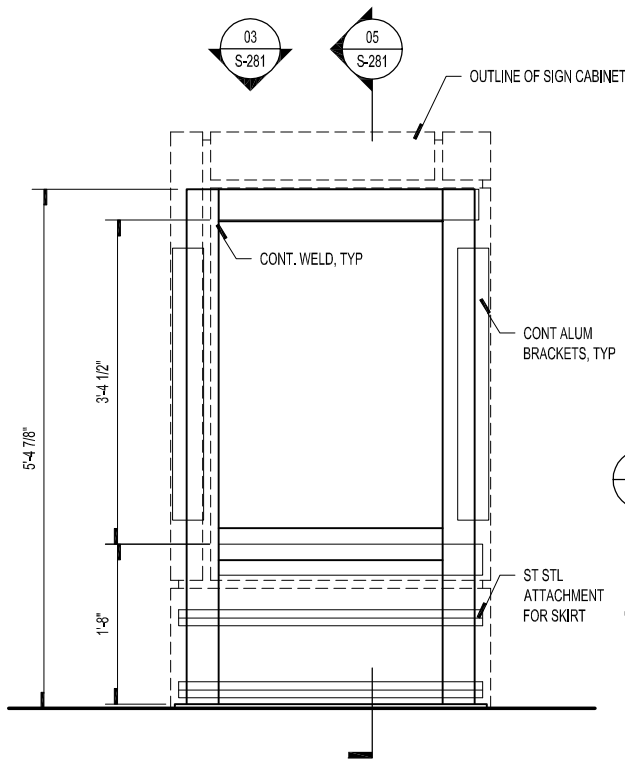

**04** SIGN BOX TYPE S-281  
INTERNAL STRUCTURE - SECTION

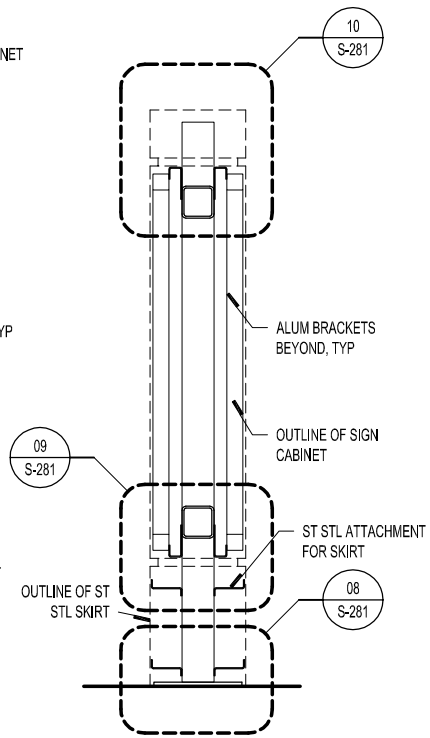

**05** SIGN BOX TYPE S-281  
INTERNAL STRUCTURE - CROSS SECTION

Fabrication Details for Sign Box Type S-281

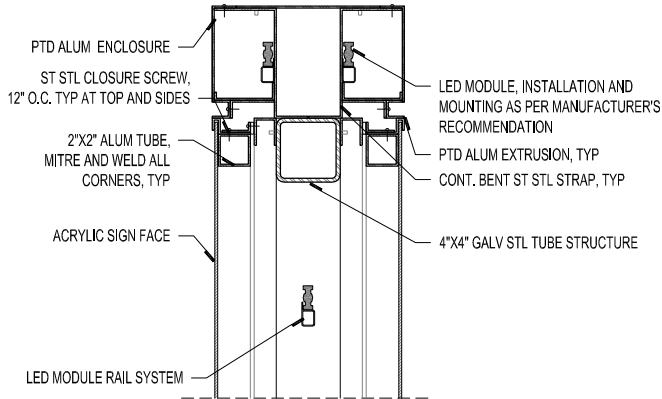

**10** SIGN BOX TYPE S-281  
TOP DETAIL

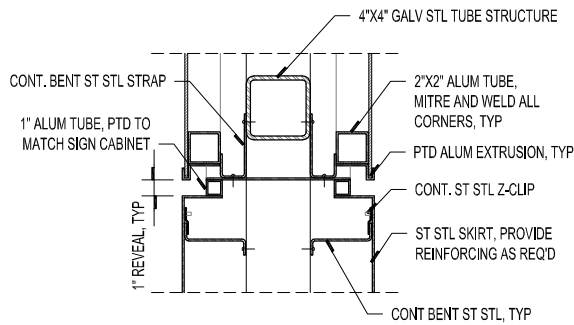

**09** SIGN BOX TYPE S-281  
BOTTOM DETAIL

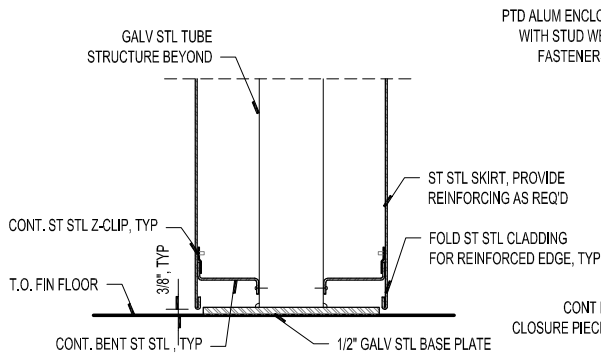

**08** SIGN BOX TYPE S-281  
BASE DETAIL

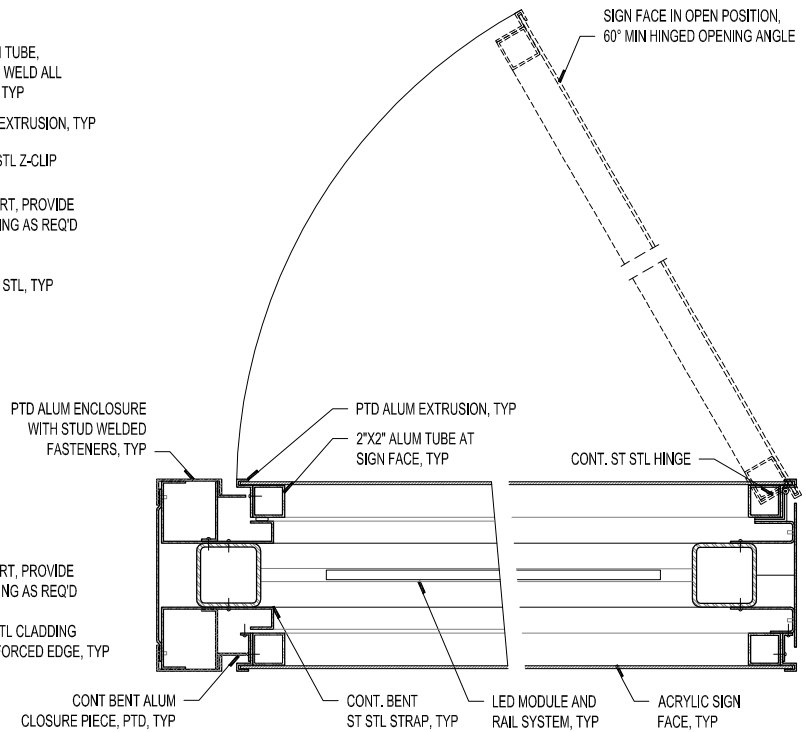

**11** SIGN BOX TYPE S-281  
PLAN / SECTION DETAIL



### 6.3 PARKING SIGN BOXES

Sign Box Types at the Airports' Parking Facilities include:

#### OVERHEAD SIGN BOXES

Sign Box Type A - Ceiling Mounted

Sign Box Type A-I - Ceiling Mounted - Internally Illuminated

Sign Box Type B - Soffit Mounted

#### OVER-ROADWAY SIGN BOXES

Sign Box Type E-1 - Length up to 12'-0"

Sign Box Type E-2 - Length up to 18'-0"

#### FLAGS

Sign Box Type F-1 - Wall Flag - Aluminum Face

#### PLAQUES

Sign Box Type G-3 - Plaque - Aluminum Brake-Formed Pan

#### SPECIALTY SIGN BOXES

Sign Box Type S-365 - Terminal Icon - Ground Mounted

Sign Box Type S-366 - Floor Level ID Pylon

Sign Box Type S-370 - Terminal Icon - Surface Mounted

*The drawings shown in this section are available for digital download by clicking on the link on each drawing.*

## Overhead Sign Boxes (Sign Types A and B)

### Usage and Application

Overhead Sign Boxes are used for the majority of wayfinding signs located throughout the airport. They are designed to be easily customized to accommodate any message length or location. Overhead Sign Boxes are used with the following sign applications:

#### Primary Messages

- Identification
- Directional
- Informational

#### Secondary Messages

- Identification
- Directional
- Informational

### Methodology

Overhead Sign Boxes use standard aluminum extrusions that are reinforced with bent aluminum forks. The material of the sign face for these sign boxes is acrylic. The detailing of the sign boxes vary depending on length of the sign box, method of mounting the sign box, and whether or not the sign box is illuminated.

### Mounting Types

There are two ways these sign boxes are mounted:

**Mount Type A** is suspended from the ceiling or structure above. The details for this sign include an alternative mounting condition using unistrut brackets in lieu of aluminum pipes.

**Mount Type B** is attached to a soffit or a wall.

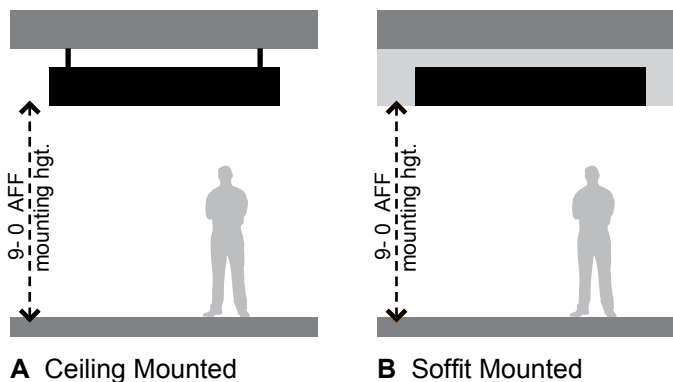

The mount type changes the internal reinforcing of the sign box and is independent of the length of the sign box.

**Length Types**

There are three length types for these sign boxes:

**Length Type 1** is up to 6 feet in length.

**Length Type 2** is from 6 feet to 12 feet in length.

**Length Type 3** is from 12 feet to 18 feet in length.



The height of the sign box is independent of the sign type. All sign box types can accommodate up to 3 lines of messaging and a header. Heights beyond 3'-0" and lengths beyond the table below are considered custom.

**Illumination**

All overhead sign boxes can be internally illuminated if desired. Illumination and lighting details vary with the length of the box and whether or not the sign box is double sided. Depending on the technology at the time of fabrication, a larger extrusion may need to be used to increase the distance between the LEDs and the sign face to avoid hot spots. A lighting diagram is provided for Sign Box Type A and is shown for a double sided internally illuminated sign, but the same concept can be applied to a single-sided internally-illuminated sign, or Box Type B.

### **Sign Box Type Designation**

The Sign Box Type designation for Overhead Sign Boxes are a combination of Mount Type, Length Type, and whether or not the sign box is illuminated.

#### ***Mount Type - Length Type - Illumination***

Illuminated sign boxes are given an “I” to indicate the box has illumination details. Non-illuminated sign boxes receive no designation and are either lit through ambient light or direct external illumination.

An example for a 12 foot, 2-line, illuminated sign box that is suspended from the ceiling is Sign Box Type A-2-I. The “A” denotes a suspended from the ceiling mounting, the “2” denotes a 12-foot-long sign box, and “I” denotes illumination. This nomenclature should appear in the contract documents.

Overhead Sign Box Drawings

Details for Sign Box Types A-1, A-2, and A-3 (Ceiling Mounted)

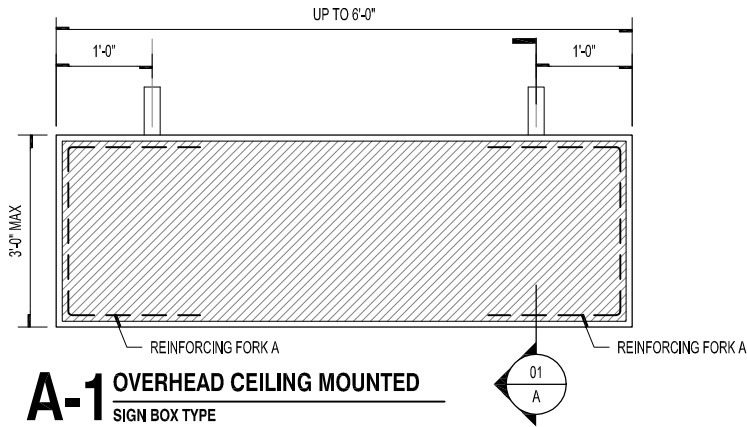

NOTE: SEE REINFORCING DETAILS FOR REINFORCING TYPES AND EXTRUSION DETAILS FOR EXTRUSION TYPES.

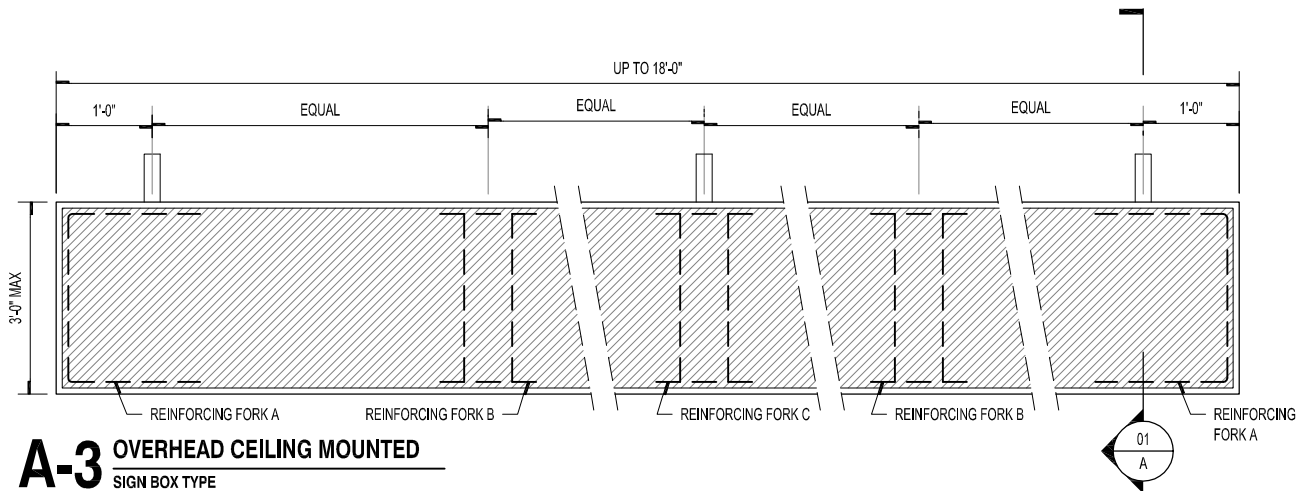
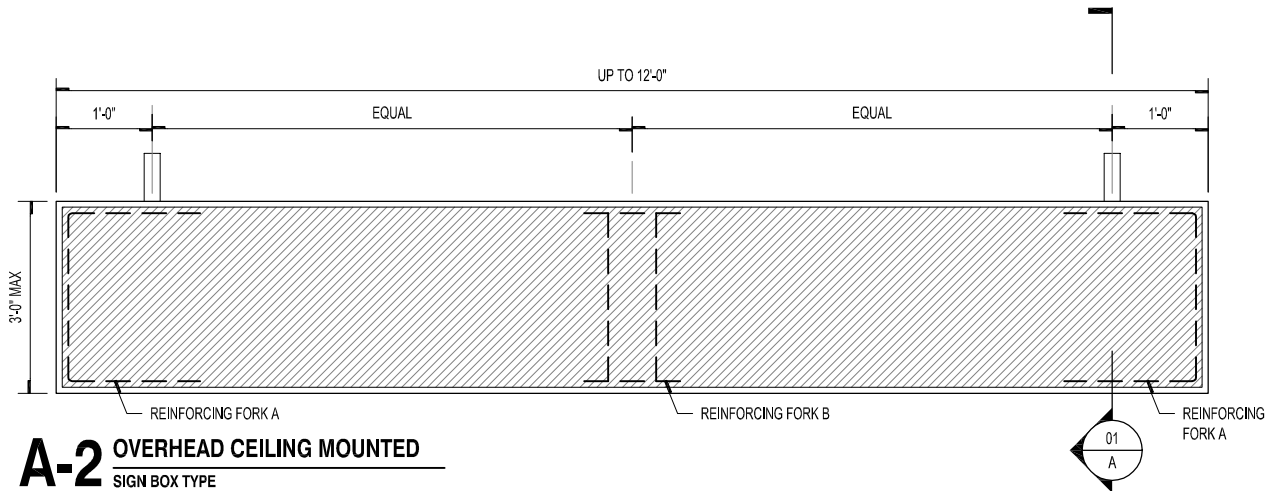

Fabrication Details for Sign Box Types A-1, A-2, and A-3

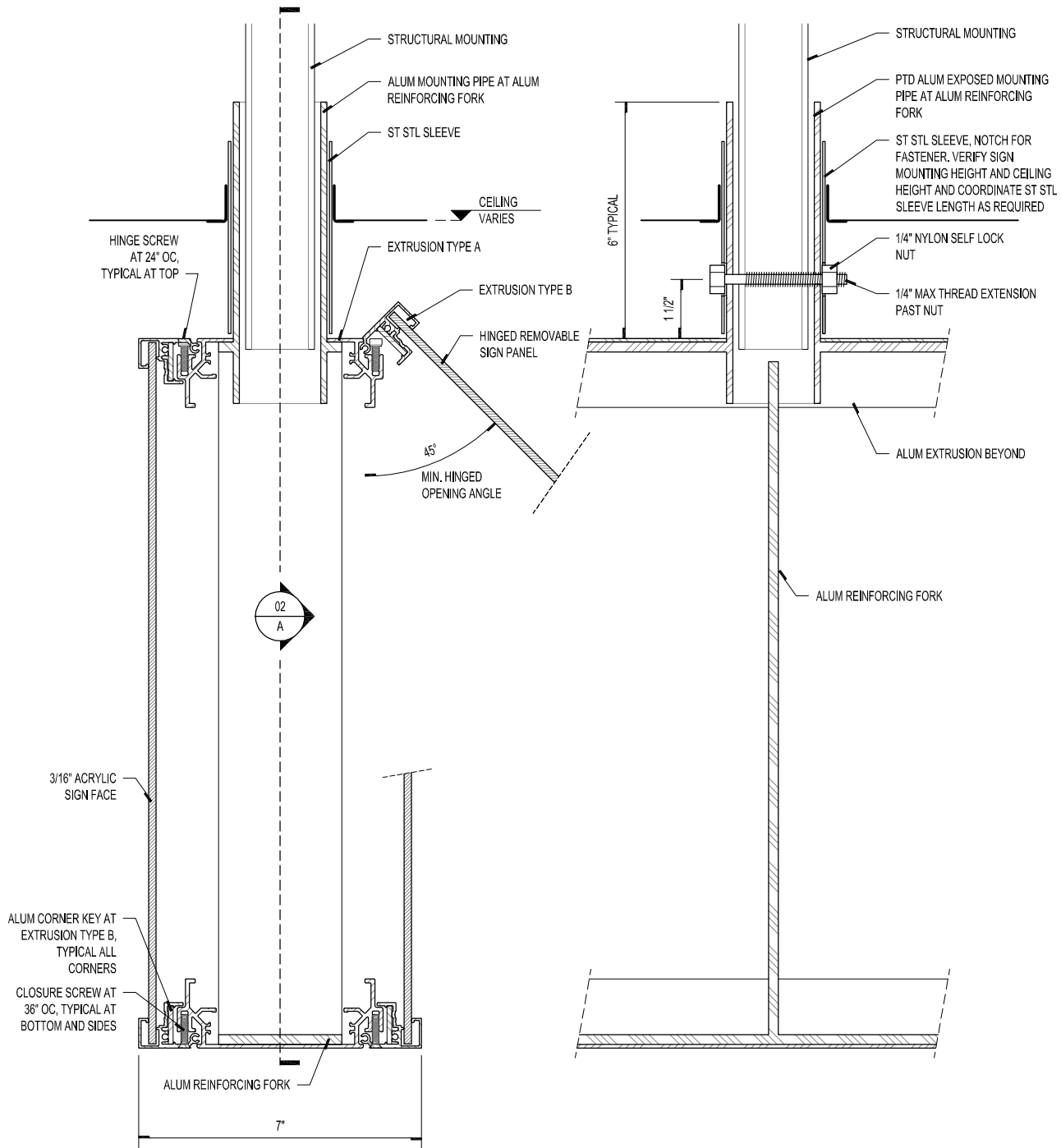

**01** SIGN BOX TYPES A-1, A-2, AND A-3  
TYPICAL SECTION

**02** SIGN BOX TYPES A-1, A-2, AND A-3  
TYPICAL SECTION



**Fabrication Details for Sign Box Types A-1, A-2, and A-3 (Ceiling Mounted)**

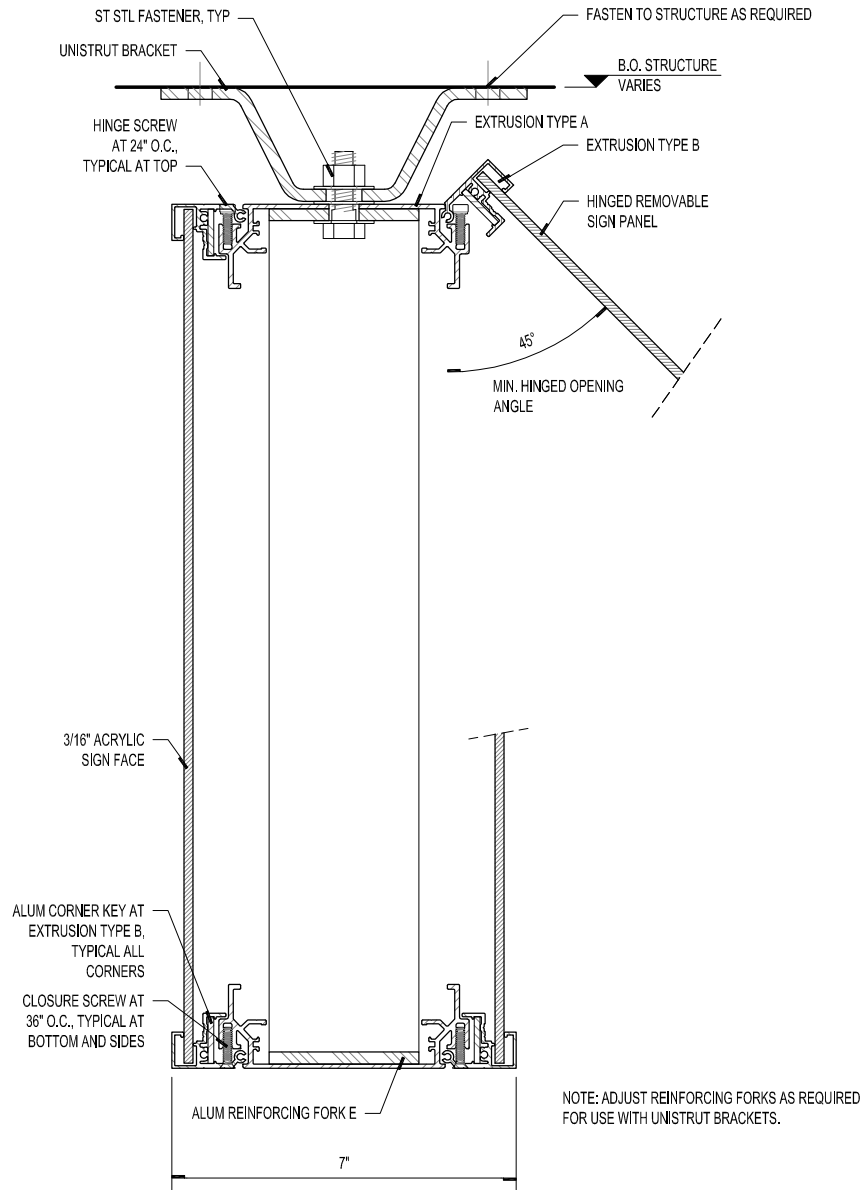

**03** SIGN BOX TYPES A-1, A-2, AND A-3 (ALTERNATE)  
TYPICAL SECTION

Lighting Diagram for Sign Box Types A-1-I, A-2-I, and A-3-I

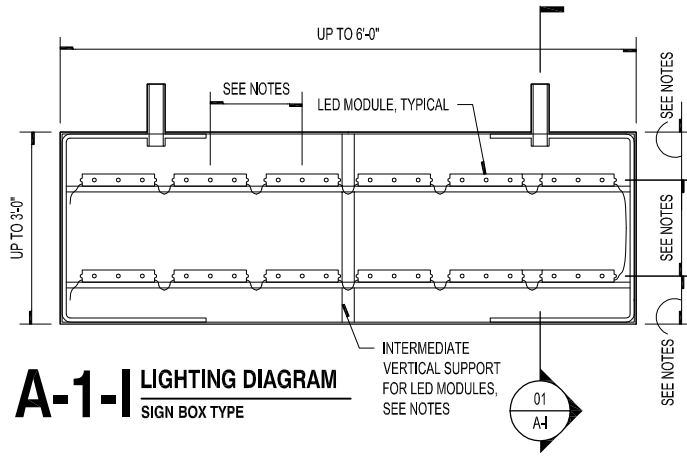

**A-1-I LIGHTING DIAGRAM**  
SIGN BOX TYPE

- NOTES:
1. LED MODULES SHOWN ON BOX TYPE A. ILLUMINATION CONCEPT APPLIES TO BOX TYPES A AND B.
  2. LAYOUT SHOWN FOR A BOX HEIGHT OF 2'-0". ADJUST NUMBER OF LED MODULES AND SPACING AS REQUIRED FOR BOX TYPES ABOVE AND BELOW 2'-0" IN HEIGHT.
  3. SPACE LED MODULES AS RECOMMENDED BY LED MODULE MANUFACTURER.
  4. PROVIDE INTERMEDIATE VERTICAL SUPPORTS EVERY 4'-0" O.C. OR AS RECOMMENDED BY LED MODULE MANUFACTURER. COORDINATE LOCATION OF SUPPORTS WITH LED MODULES TO PROVIDE EVEN ILLUMINATION AVOIDING SHADOWS AND HOT SPOTS.
  5. SEE REINFORCING DETAILS FOR REINFORCING TYPES AND EXTRUSION DETAILS FOR EXTRUSION TYPES.

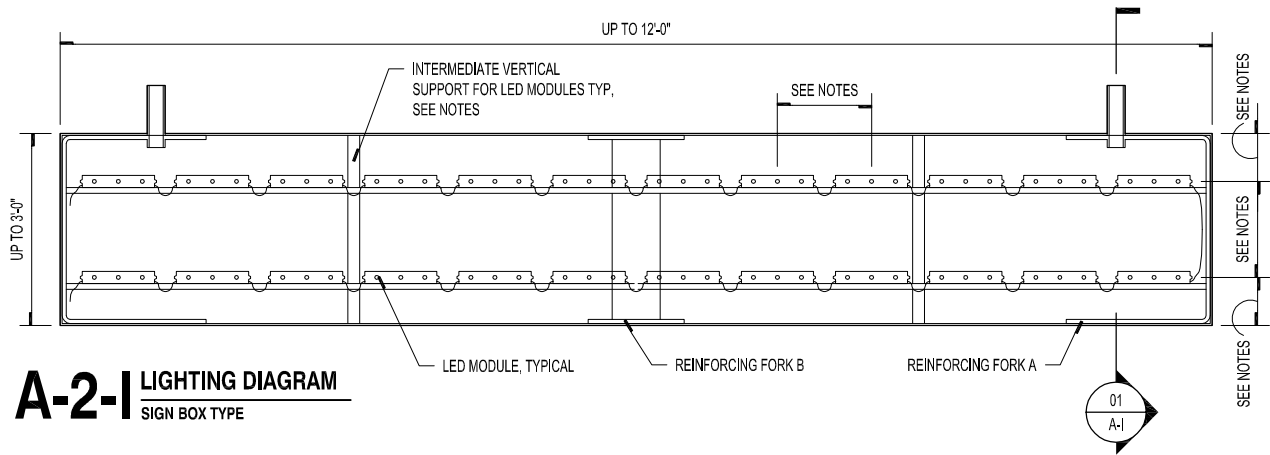

**A-2-I LIGHTING DIAGRAM**  
SIGN BOX TYPE

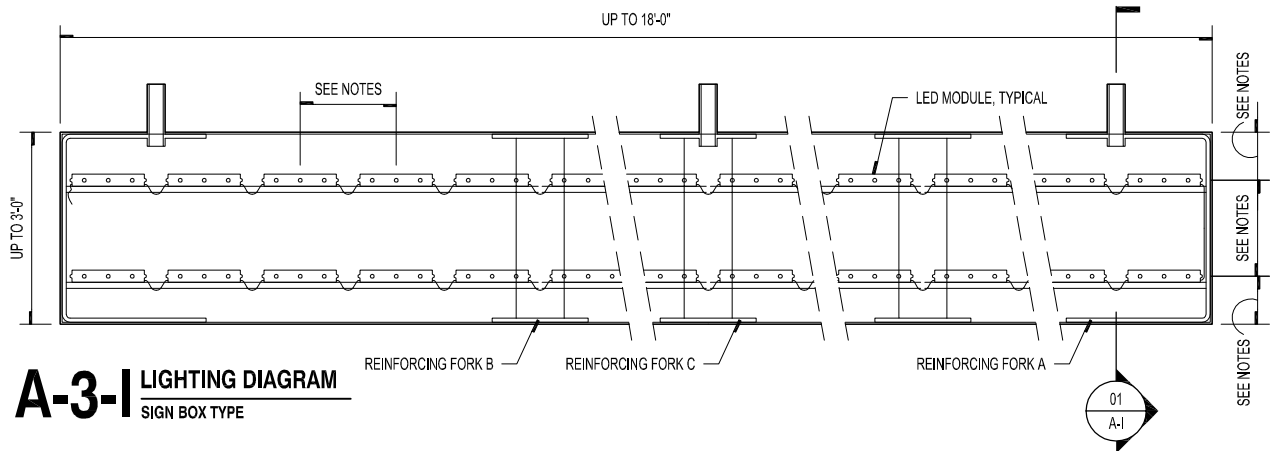

**A-3-I LIGHTING DIAGRAM**  
SIGN BOX TYPE

**Fabrication Details for Sign Box Types A-1-I, A-2-I, and A-3-I (Ceiling Mounted)**

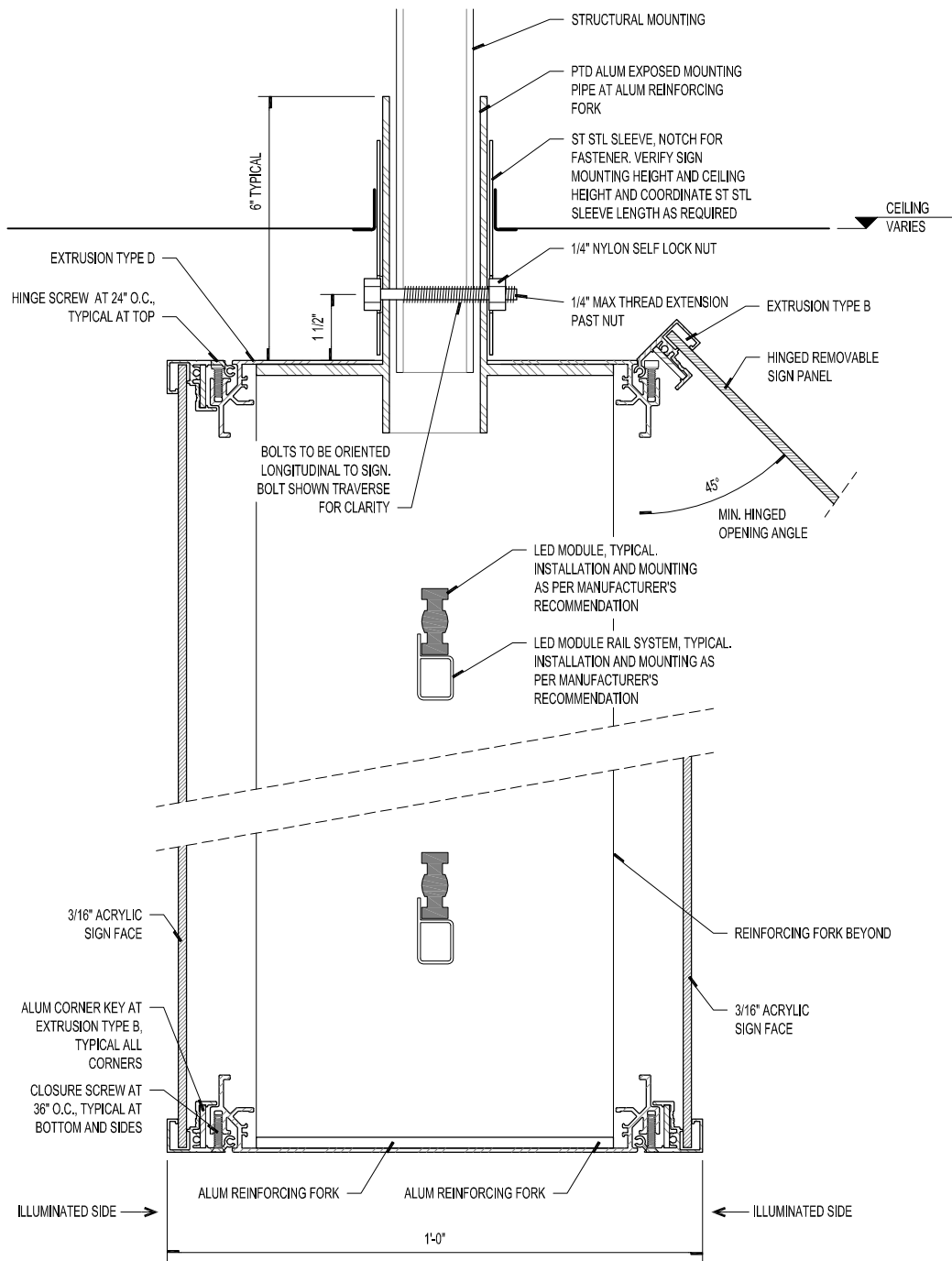

**01** SIGN BOX TYPE A-1-I, A-2-I, AND A-3-I  
TYPICAL SECTION

Details for Sign Box Types B-1, B-2, and B-3 (Soffit Mounted)

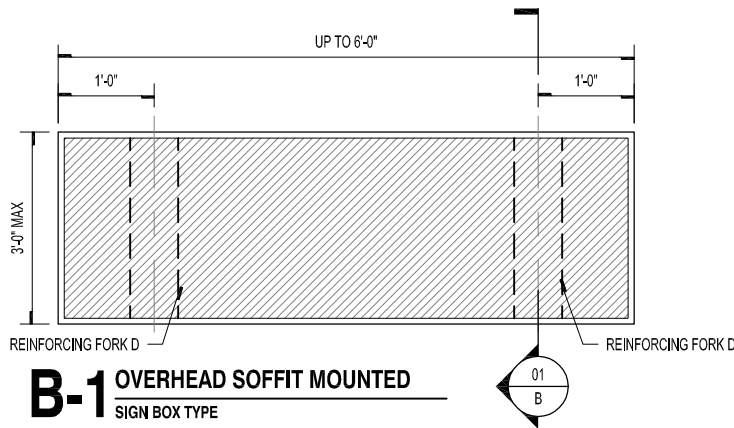

NOTE: SEE REINFORCING DETAILS FOR REINFORCING TYPES AND EXTRUSION DETAILS FOR EXTRUSION TYPES.

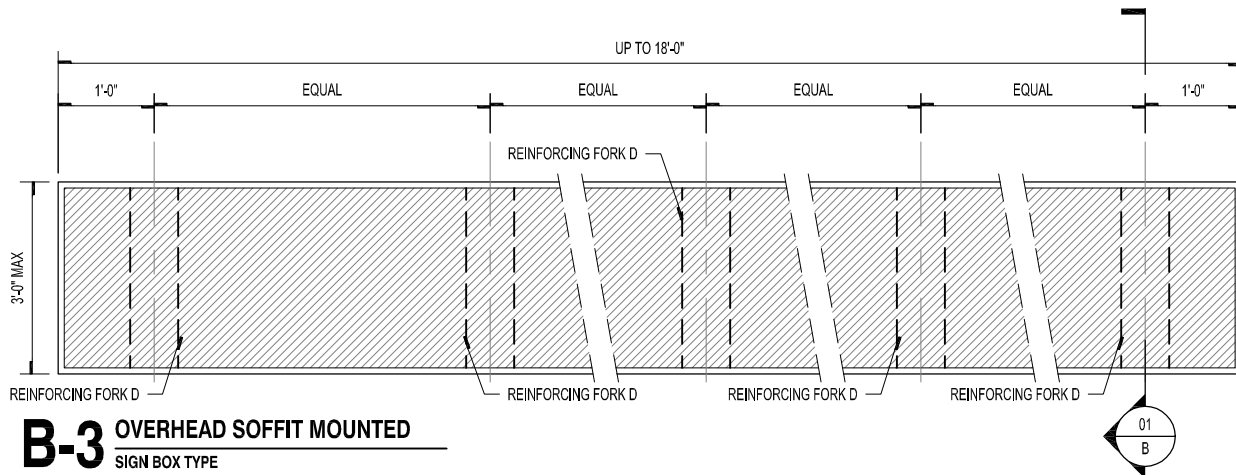
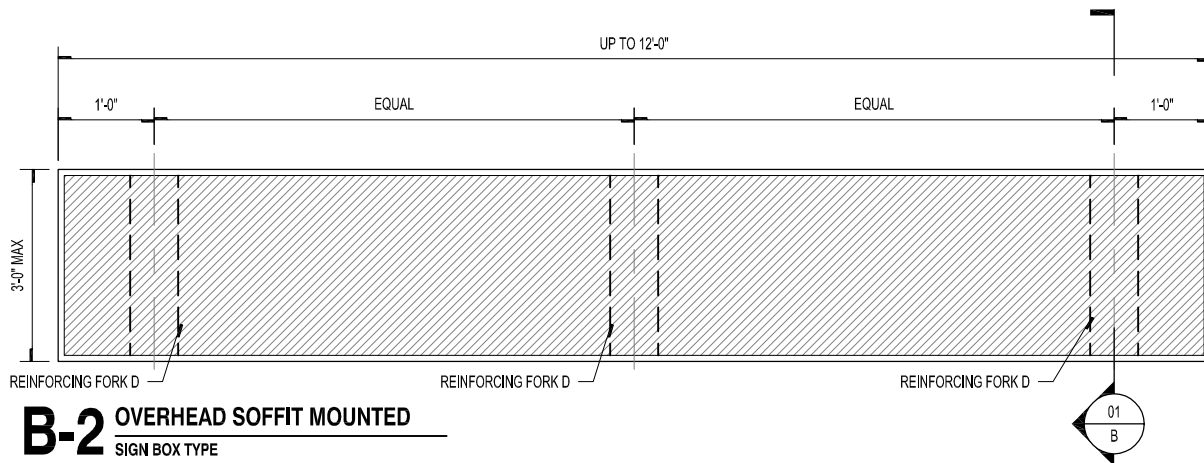

**Fabrication Details for Sign Box Types B-1, B-2, and B-3**

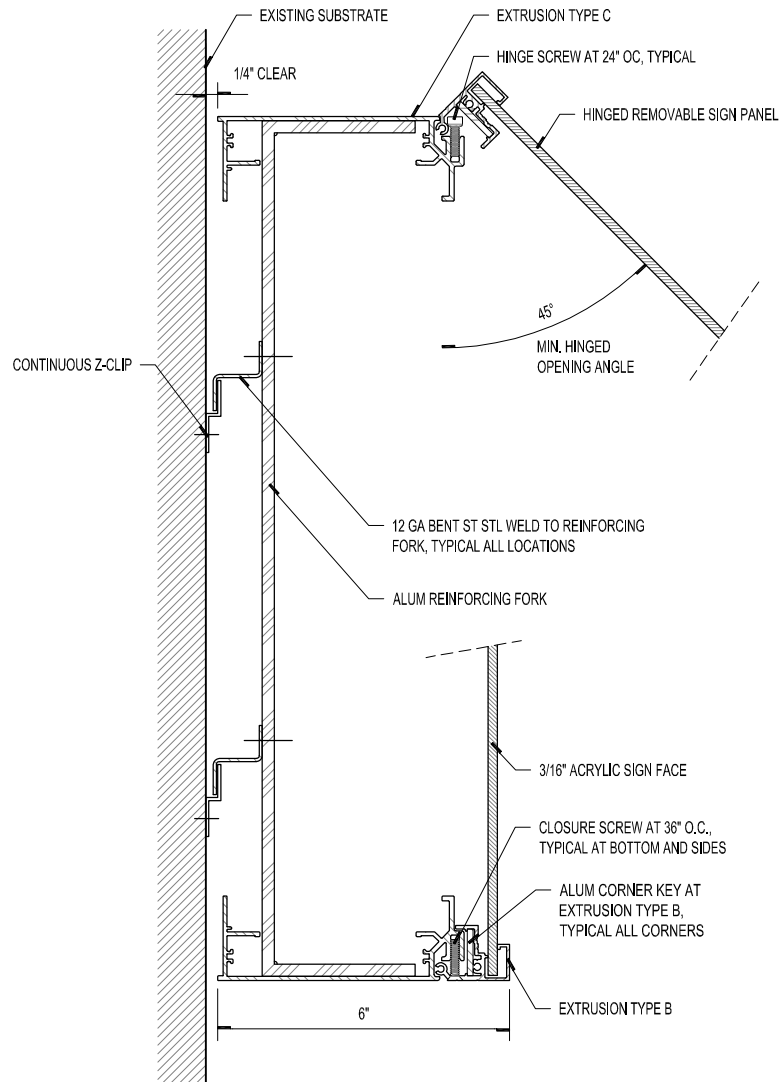

**01** SIGN BOX TYPES B-1, B-2, AND B-3  
TYPICAL SECTION

Reinforcing Details for Overhead Sign Boxes

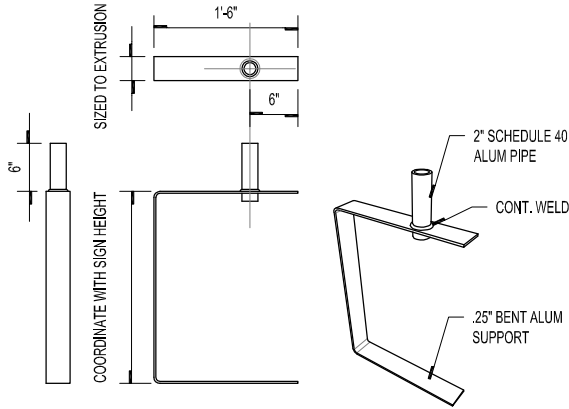

**01** REINFORCING FORK A

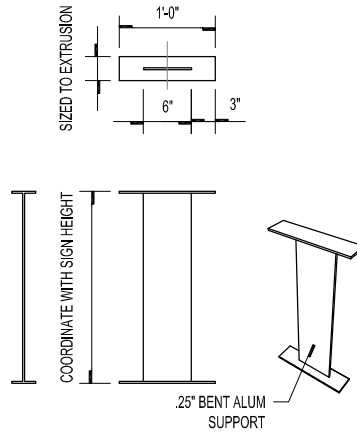

**02** REINFORCING FORK B

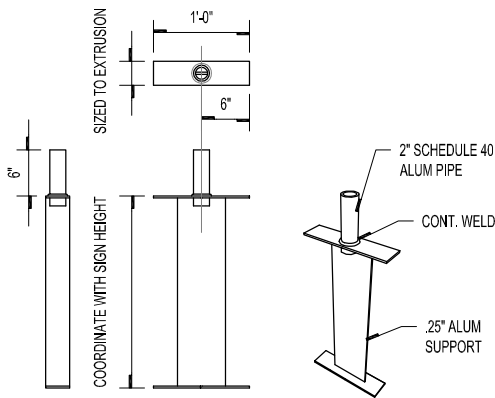

**03** REINFORCING FORK C

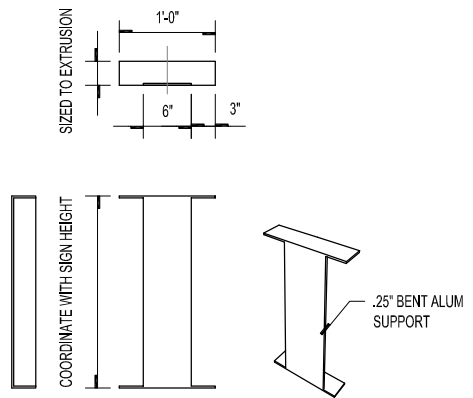

**04** REINFORCING FORK D

*Extrusion Types for Overhead Sign Boxes*

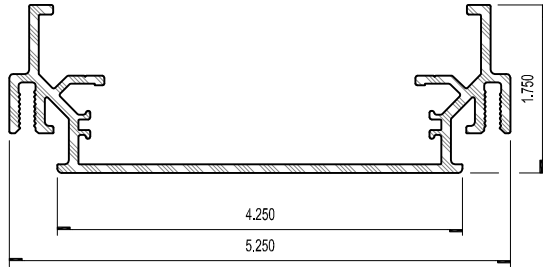

**01** EXTRUSION TYPE A  
SIGNCOMP SERIES 7

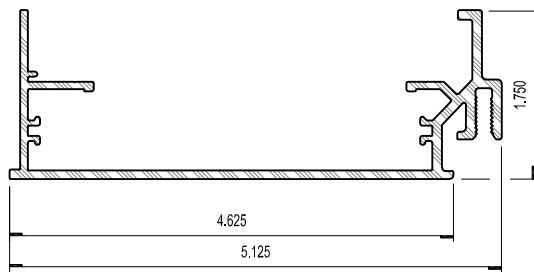

**02** EXTRUSION TYPE C  
SIGNCOMP SERIES 7

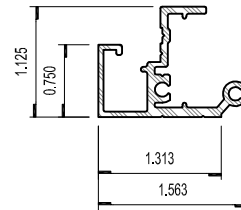

**03** EXTRUSION TYPE B  
SIGNCOMP SERIES 7

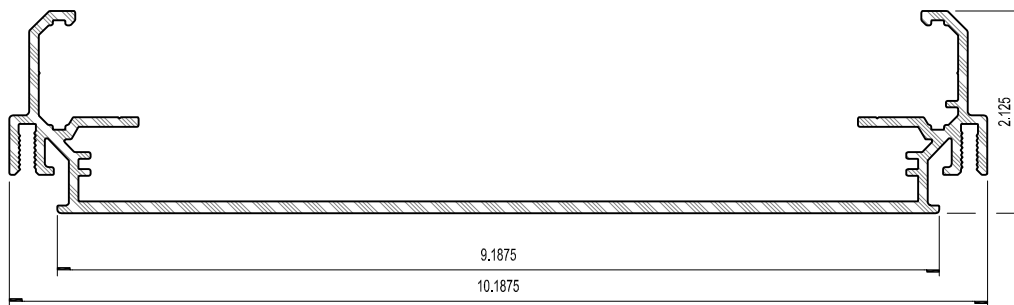

**04** EXTRUSION TYPE D  
SIGNCOMP SERIES 12 - HINGE BODY

## Over-Roadway Sign Boxes (Sign Box Type E)

### Usage and Application

Over-Roadway Sign Boxes are used for vehicular wayfinding signs located above the roadway at terminal curbsides and at select signs in parking areas. Over-Roadway Sign Boxes are used with the following sign applications:

#### Primary Messages

- Identification
- Directional
- Informational

#### Secondary Messages

- Identification
- Directional
- Informational

### Methodology

Over-Roadway Sign Boxes are detailed using an aluminum tube frame for the structure. The material of the sign face is aluminum and is attached to the frame using aluminum angles and ultra or very high bond (VHB) tape. The detailing of the sign boxes vary depending on length of the sign box. The details for this sign include an alternative mounting condition using linked eyelets in lieu of aluminum pipes.

### Sign Box Types

There are two sign box types for Over-Roadway signs based on length.

**Sign Box Type E-1** is up to 12 feet in length.

**Sign Box Type E-2** is from 12 feet to 18 feet in length.

Lengths beyond 18'-0" are considered custom. The height of the sign box is independent of the sign type, but heights above 1'-0" are also considered custom.



### Mounting Type

These sign boxes are suspended over the roadway from the structure above.

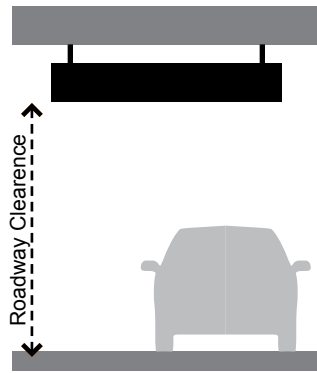

Over Roadway

Over-Roadway Sign Box Drawings  
 Details for Sign Box Types E-1 and E-2

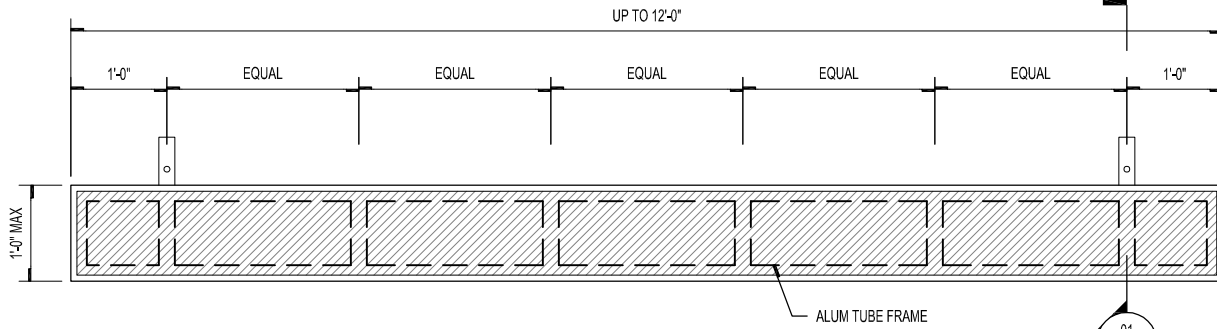

**E-1** OVER-ROADWAY  
 SIGN BOX TYPE

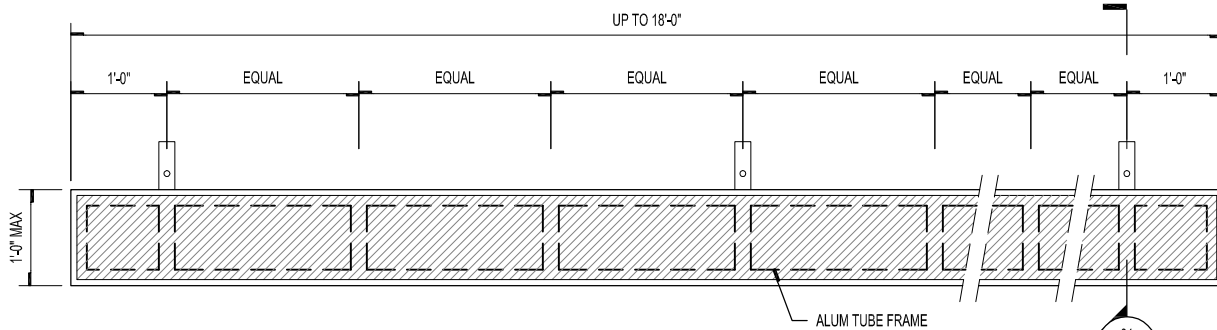

**E-2** OVER-ROADWAY  
 SIGN BOX TYPE

*Fabrication Details for Sign Box Types E-1 and E-2*

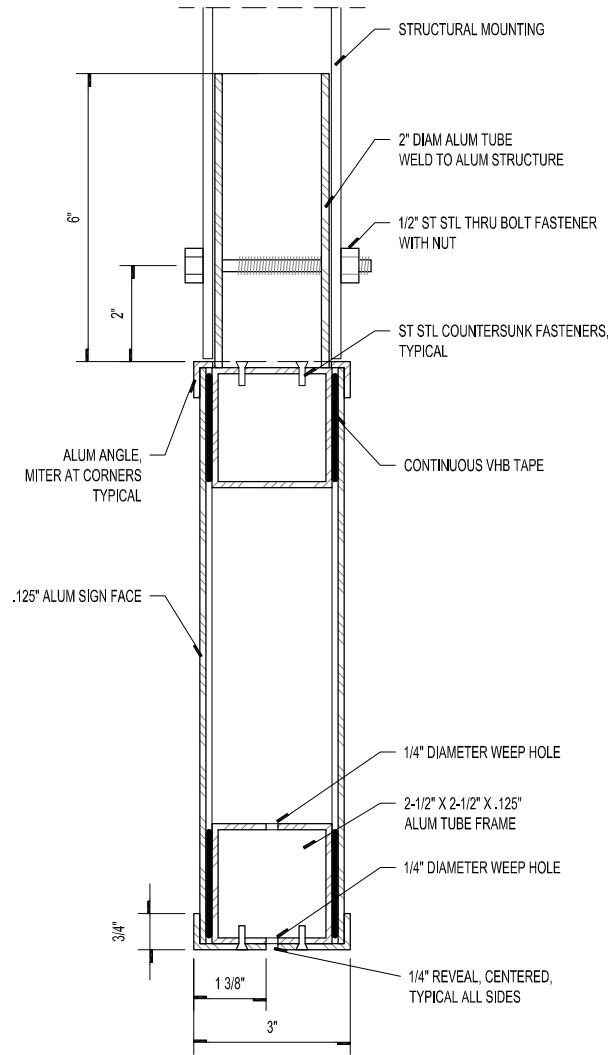

**01** SIGN BOX TYPES E-1 AND E-2  
TYPICAL SECTION

**Fabrication Details for Sign Box Types E-1 and E-2 - Alternate Mounting**

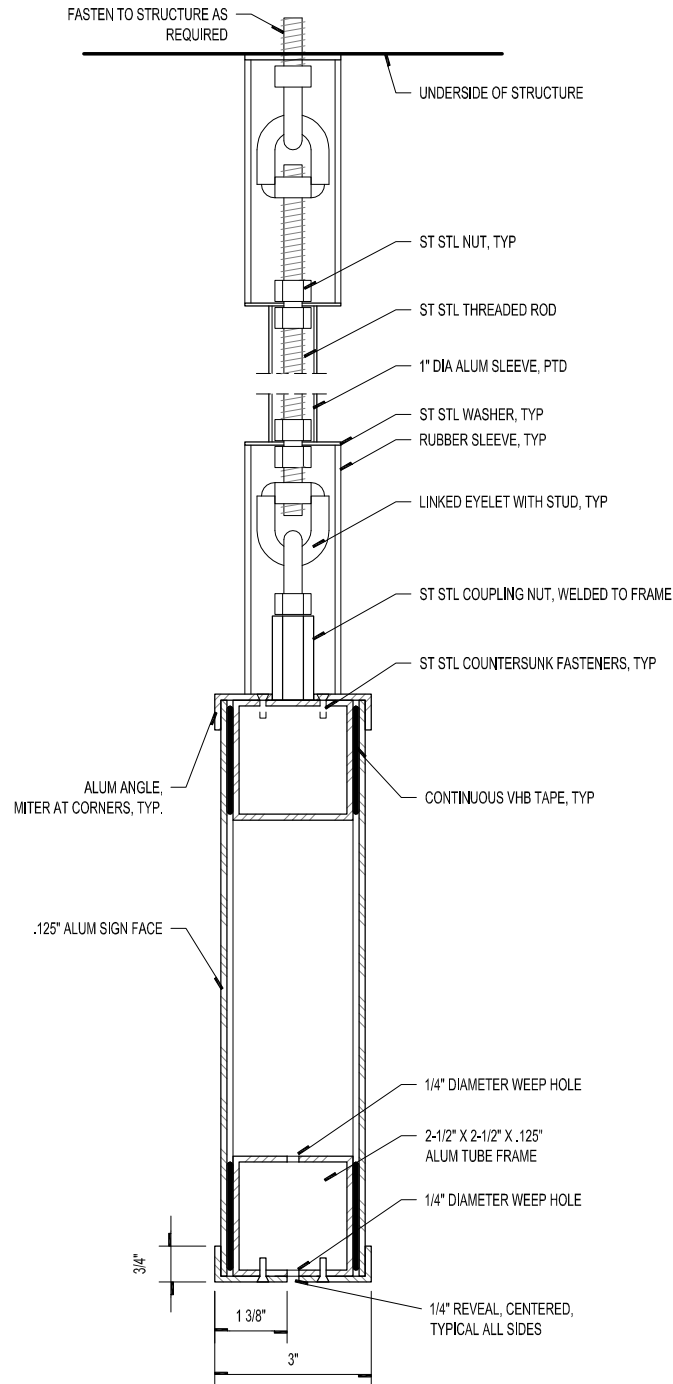

**02 SIGN BOX TYPES E-1 AND E-2 (ALTERNATE)**  
TYPICAL SECTION

## Flags and Plaques (Sign Box Type F and G)

### Usage and Application

Flags and Plaques are generally smaller signs used for secondary messages that are mounted to a wall or ceiling. They are used with the following sign applications:

Primary Messages	Secondary Messages
<input type="checkbox"/> Identification	<input checked="" type="checkbox"/> Identification
<input type="checkbox"/> Directional	<input checked="" type="checkbox"/> Directional
<input checked="" type="checkbox"/> Informational	<input checked="" type="checkbox"/> Informational

### Methodology

Flags are detailed using an aluminum face that is attached to an aluminum frame using ultra or very high bond (VHB) adhesive tape. The frame is constructed using aluminum channels and is hidden from view behind the face. The construction of the sign allows the profile to remain thin.

Plaques at parking areas are detailed using a painted aluminum brake-formed pan with applied graphics. Plaques are used for a variety of different sign applications that range in size, but the detailing remains the same regardless of application type.

### Mounting

Flags are double faced signs suspended from the top of the sign. Plaques are single-faced signs mounted to a wall or surface.

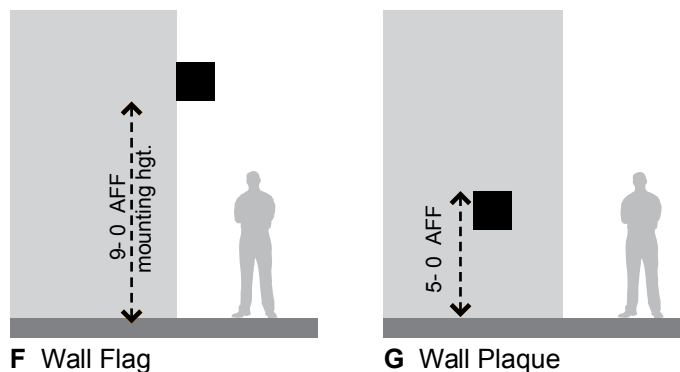

### **Illumination**

Neither of these sign box types are illuminated.

### **Sign Box Type Designation**

There are separate Sign Box Type designations for flags and plaques.

**Sign Type F-1** is a wall flag with a painted aluminum face and applied vinyl graphics.

**Sign Type G-3** is a surface mounted plaque that is a painted aluminum brake-formed pan with applied graphics.

Plaque Sign Box Drawings  
 Details for Sign Box Type F-1

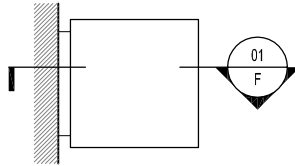

**F-1 WALL FLAG**  
 SIGN BOX TYPE  
 NOTE: SEE SECTION 5 FOR SIGN DIMENSIONS

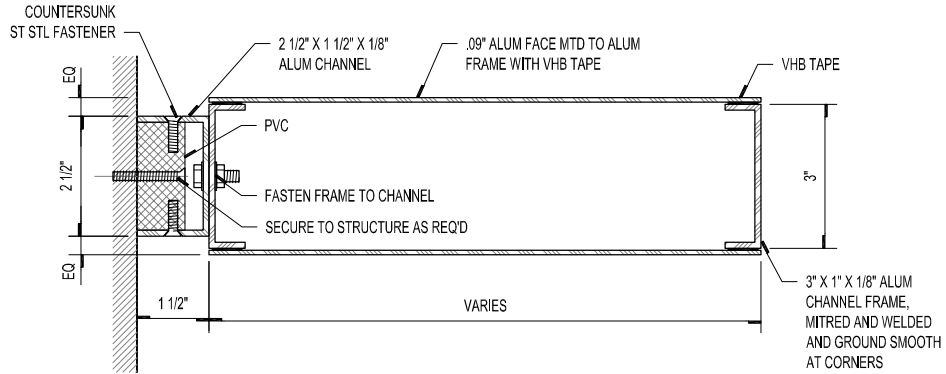

**01 SIGN BOX TYPE F-1**  
 TYPICAL SECTION

Plaque Sign Box Drawings  
 Details for Sign Box Type G-3

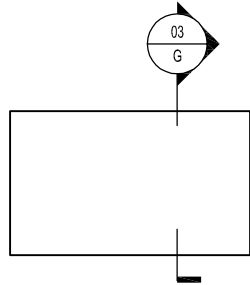

**G-3** PLAQUE  
 SIGN BOX TYPE

NOTE: SEE SECTION 5 FOR SIGN DIMENSIONS

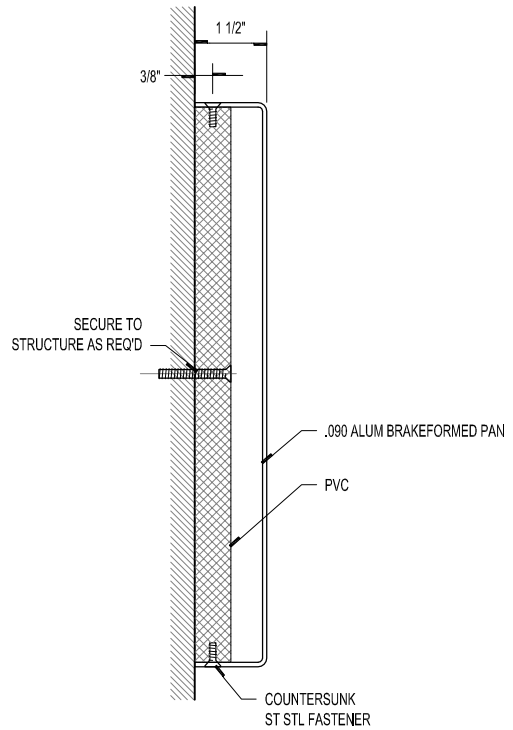

**03** SIGN BOX TYPE G-3  
 TYPICAL SECTION



## Specialty Sign Boxes (Sign Type S)

### Usage and Application

Specialty Sign Boxes are used with the following sign applications.

#### Primary Messages

- Identification
- Directional
- Informational

#### Secondary Messages

- Identification
- Directional
- Informational

### Methodology

Specialty Sign Boxes include sign boxes that are specific to their sign application.

### Sign Box Type Designation

Because these sign box types are specific to their sign application, the numerical designation for this category corresponds to the Sign Face Type designation shown in Section 5. For example, Sign Box Type S-365 is the sign box for Sign Face ST-365.

### Sign Box Types

**Sign Box Type S-365** is a ground mounted terminal Icon sign. The sign box is detailed using galvanized steel tubes for the internal structure of the sign that is clad with aluminum and secured to the structure using bent aluminum straps. The upper body of the sign consists of a trans-illuminated hinged sign face with an acrylic sign face and applied vinyl graphics. The lower body of the sign box includes a stainless steel skirt attached to the internal structure using stainless steel Z-clips.

**Sign Box Type S-366** is a Floor Level ID Pylon sign that includes a variable message system component on one side. This sign box is detailed similarly to sign box type S-365 using galvanized steel tubes for the internal structure of the sign that is clad with aluminum and secured to the structure using bent aluminum straps. The upper body of the sign consists of a hinged sign face with an acrylic sign face and applied vinyl graphics. The lower body of the sign box includes a stainless steel skirt attached to the internal structure using stainless steel Z-clips.

**Sign Box Type S-370** is a surface mounted Terminal Icon sign. The sign box type consists of an aluminum tube frame for the internal structure of the sign and a trans-illuminated aluminum hinged sign face with acrylic face and applied vinyl graphics for the cabinet. The sign box is mounted using stainless steel angles.

### Mounting Type

The mounting type varies depending on the sign box type. S-365 and S-366 are ground mounted and S-370 is surface mounted.

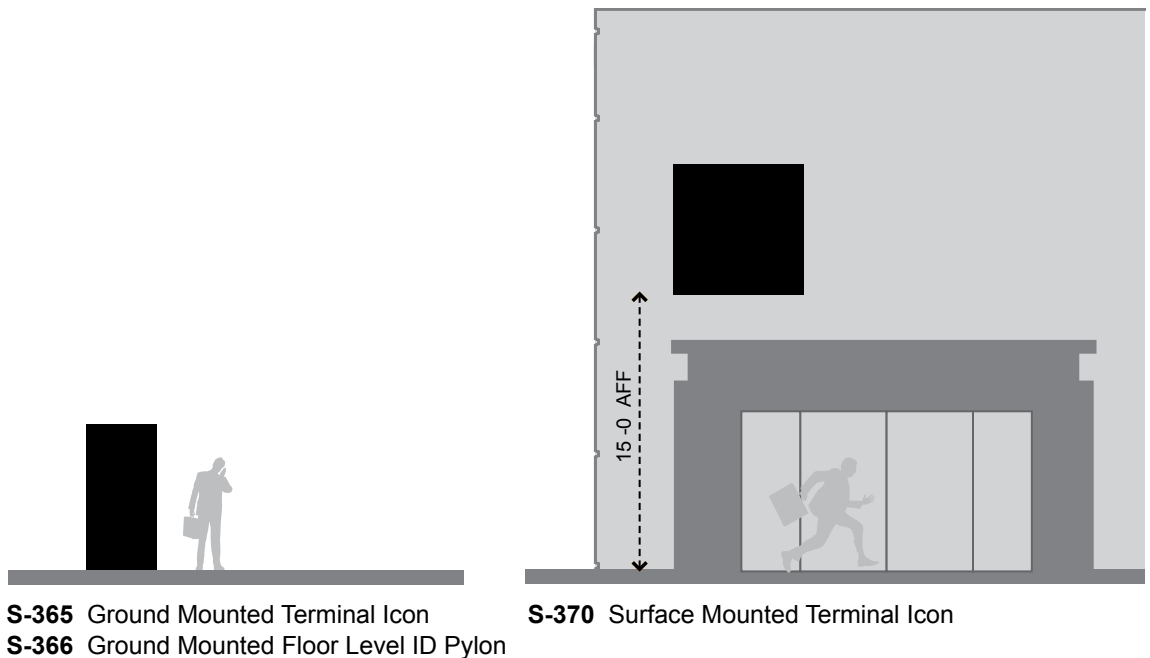

Specialty Sign Box Drawings  
 Details for Sign Box Type S-365

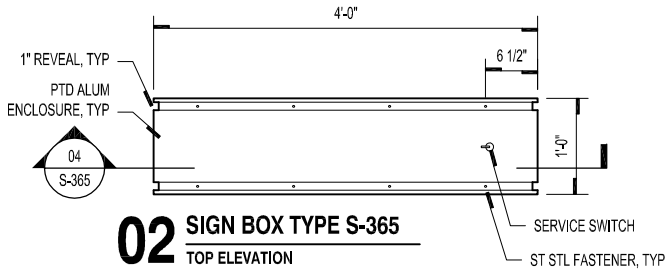

**02** SIGN BOX TYPE S-365  
 TOP ELEVATION

NOTES:

1. ALL ST STL CLADDING TO BE MITRED AND WELDED AND GROUND SMOOTH AT CORNERS AND CONNECTIONS. NO OPEN FOLDS OR CORNERS.
2. ALL EXPOSED ST STL FINISH TO BE NON-DIRECTIONAL.
3. ALL EXPOSED FASTENERS TO BE COUNTERSUNK ST STL.
4. PROVIDE NEMA RATED WATERTIGHT SERVICE SWITCH, LOCATION AS DIRECTED.
5. COORDINATE ELECTRICAL FEEDS. ALL CONDUITS TO ENTER SIGN BOX FROM BELOW.
6. PROVIDE WEEP HOLES AT EXTERIOR LOCATIONS.
7. SPACE LED MODULES AS RECOMMENDED BY LED MODULE MANUFACTURER.
8. PROVIDE INTERMEDIATE SUPPORTS AS REQUIRED OR AS RECOMMENDED BY LED MODULE MANUFACTURER. COORDINATE LOCATION OF SUPPORTS WITH LED MODULES TO PROVIDE EVEN ILLUMINATION AVOIDING SHADOWS AND HOT SPOTS.
9. TRANS-ILLUMINATED SIGN FACE TO BE HINGED ON ONE SIDE. PROVIDE PROP ARM FOR SERVICING.
10. LED MODULES TO BE WEATHERPROOF.

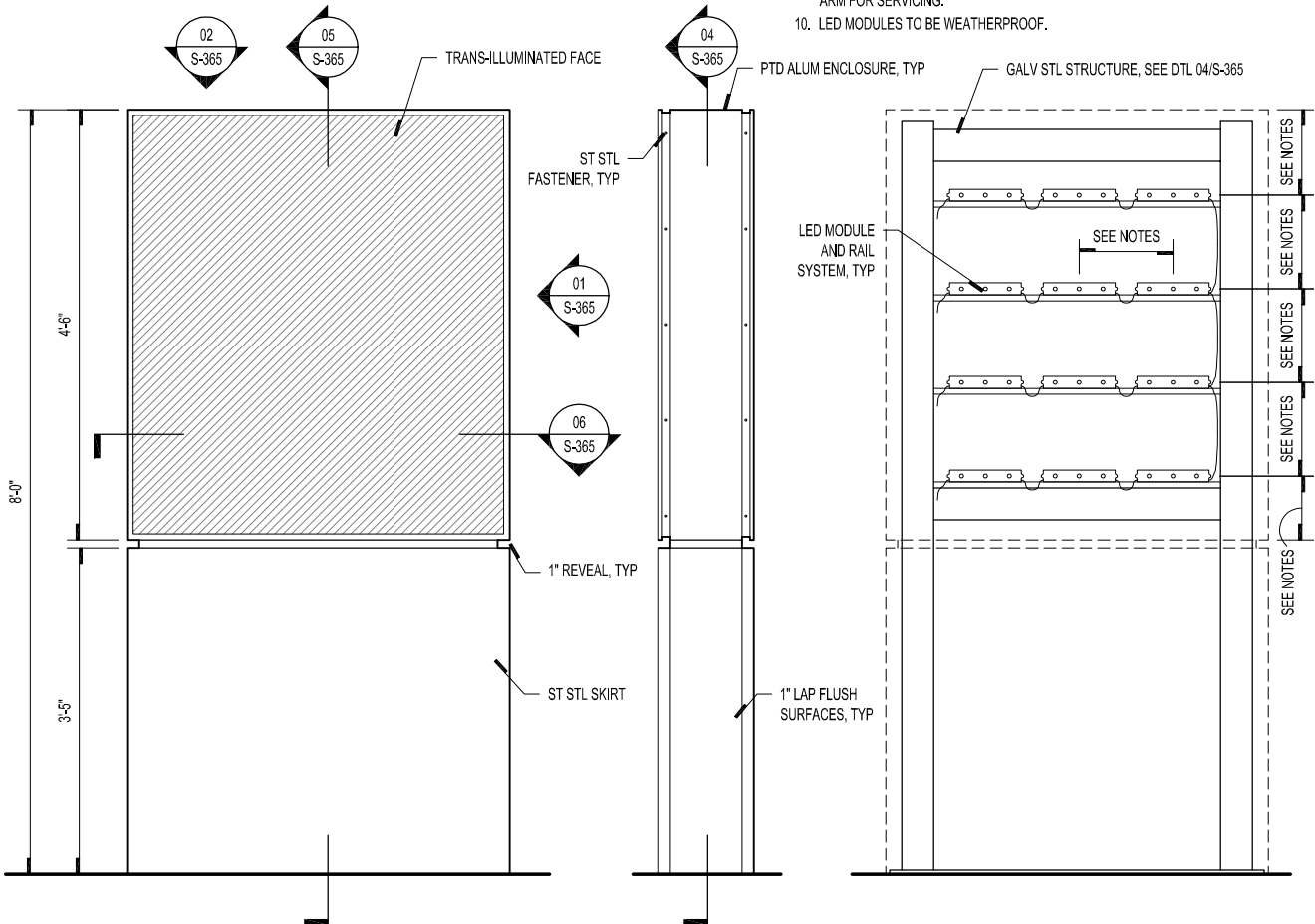

**S-365** TERMINAL ICON  
 SIGN BOX TYPE

**01** SIGN BOX TYPE S-365  
 SIDE ELEVATION

**03** SIGN BOX TYPE S-365  
 LIGHTING DIAGRAM

Fabrication Details for Sign Box Type S-365

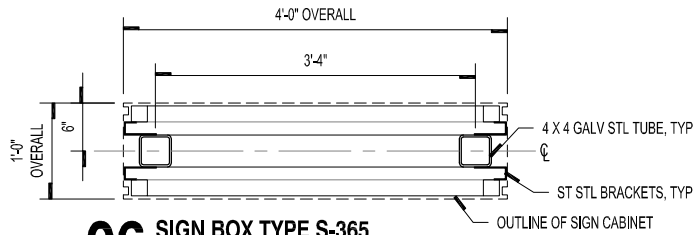

**06 SIGN BOX TYPE S-365**  
INTERNAL STRUCTURE - PLAN / SECTION (SEE 11/S-365 FOR DETAIL)

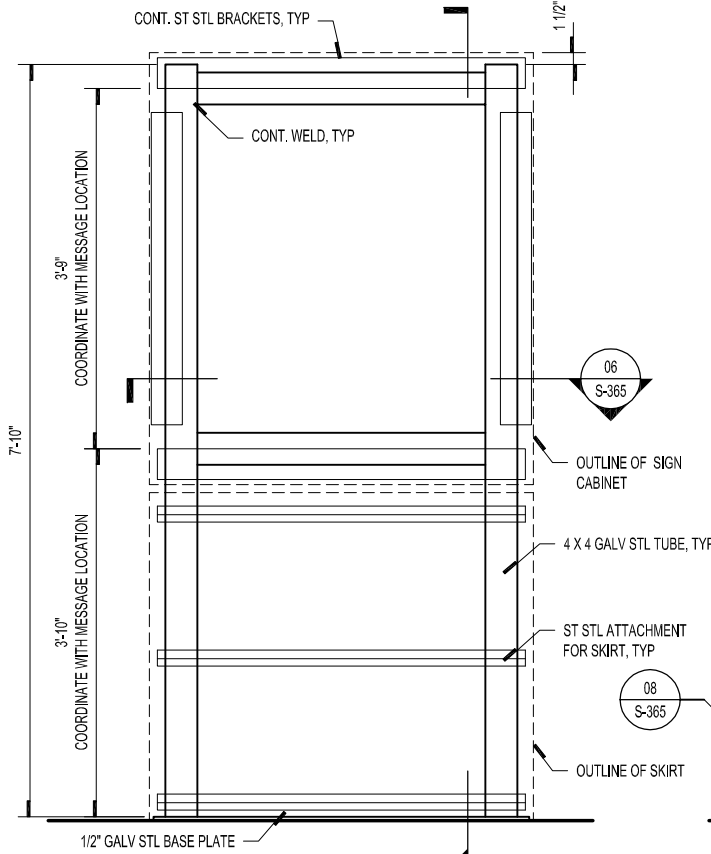

**04 SIGN BOX TYPE S-365**  
INTERNAL STRUCTURE - SECTION

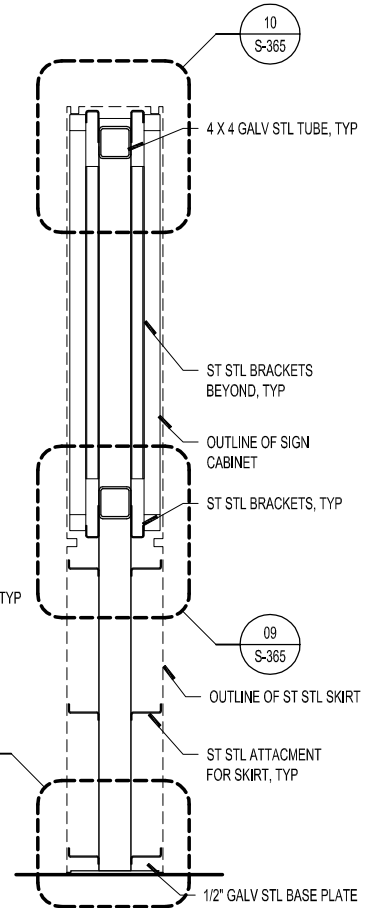

**05 SIGN BOX TYPE S-365**  
INTERNAL STRUCTURE - CROSS SECTION

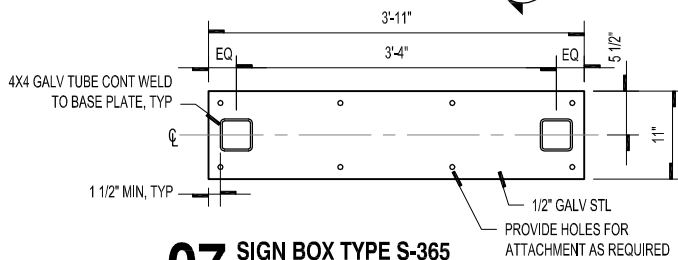

**07 SIGN BOX TYPE S-365**  
BASE PLATE

**Fabrication Details for Sign Box Type S-365**

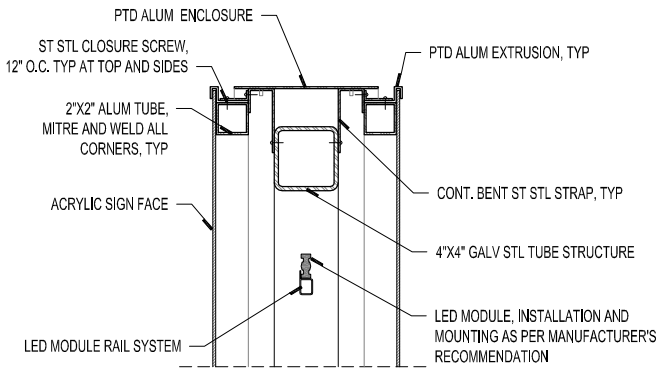

**10 SIGN BOX TYPE S-365**  
TOP DETAIL

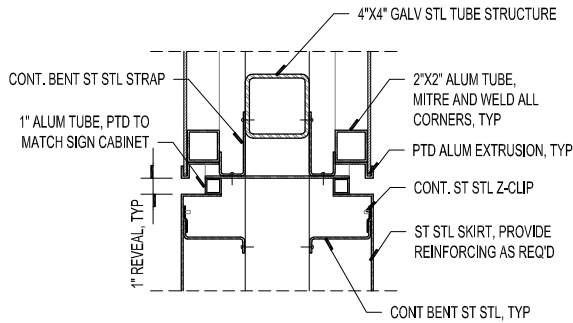

**09 SIGN BOX TYPE S-365**  
BOTTOM DETAIL

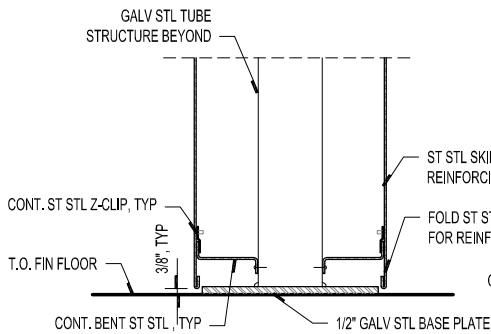

**08 SIGN BOX TYPE S-365**  
BASE DETAIL

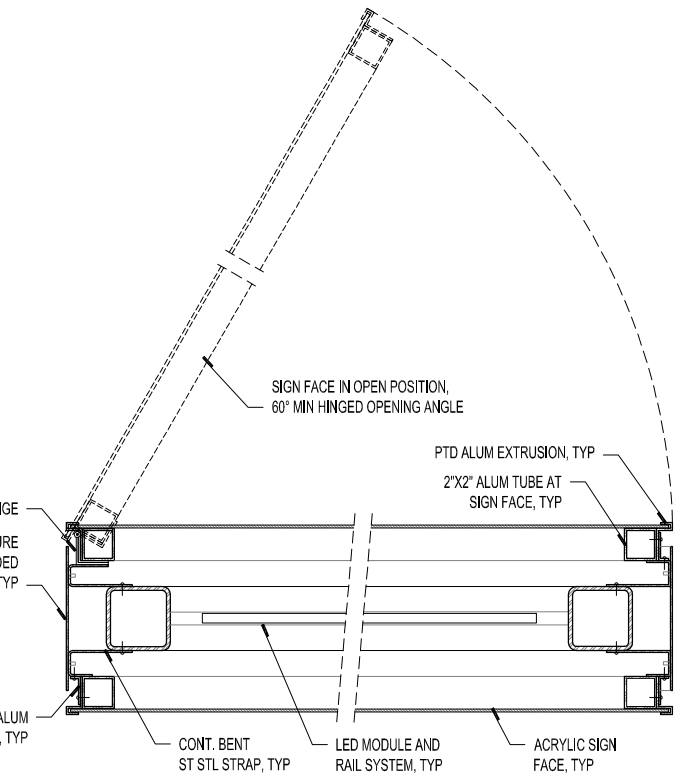

**11 SIGN BOX TYPE S-365**  
PLAN / SECTION DETAIL



Details for Sign Box Type S-366

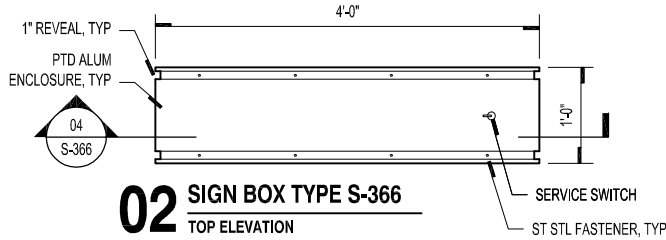

NOTES:

1. ALL ST STL CLADDING TO BE MITRED AND WELDED AND GROUND SMOOTH AT CORNERS AND CONNECTIONS. NO OPEN FOLDS OR CORNERS.
2. ALL EXPOSED ST STL FINISH TO BE NON-DIRECTIONAL.
3. ALL EXPOSED FASTENERS TO BE COUNTERSUNK ST STL.
4. PROVIDE NEMA RATED WATERTIGHT SERVICE SWITCH, LOCATION AS DIRECTED.
5. COORDINATE ELECTRICAL FEEDS. ALL CONDUITS TO ENTER SIGN BOX FROM BELOW.
6. PROVIDE WEEP HOLES AT EXTERIOR LOCATIONS.
7. SIGN FACE TO BE HINGED ON BACK SIDE. PROVIDE PROP ARM FOR SERVICING.
8. VMS DISPLAY UNIT TO BE WEATHERPROOF.

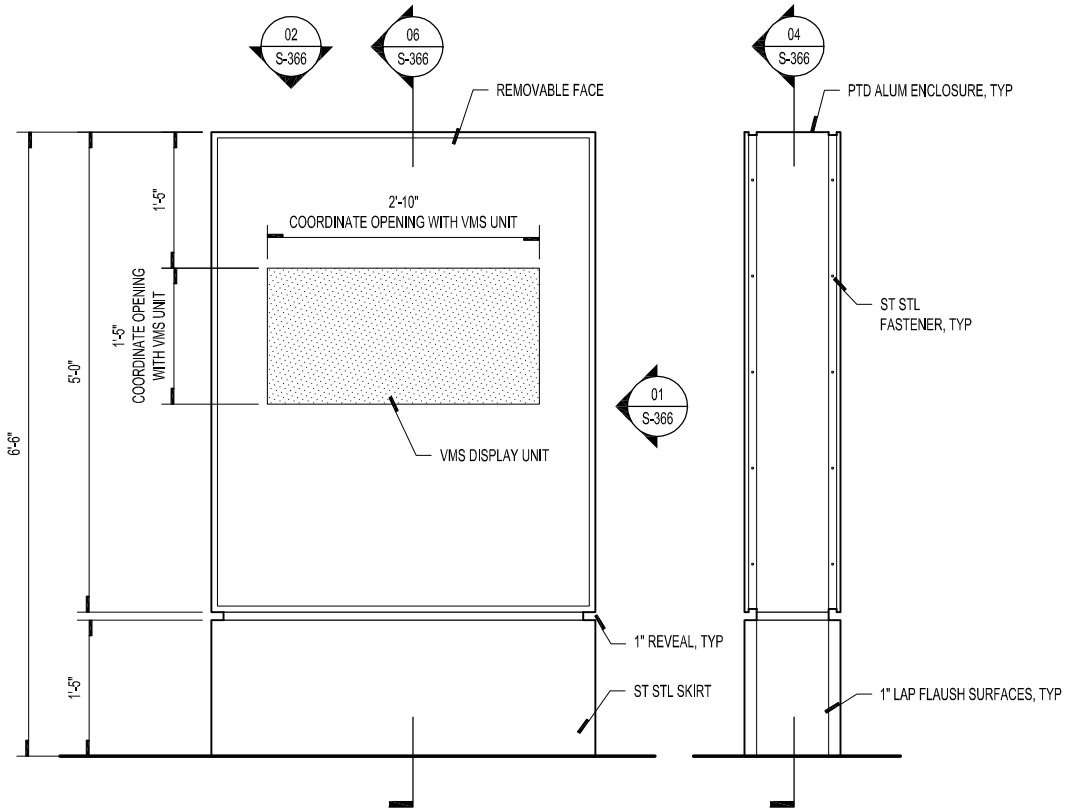

Fabrication Details for Sign Box Type S-366

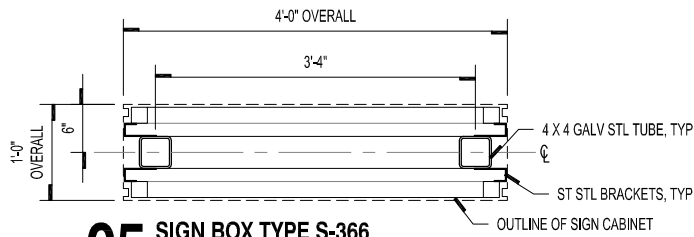

**05 SIGN BOX TYPE S-366**  
INTERNAL STRUCTURE - PLAN / SECTION (SEE 10/S-366 FOR DETAIL)

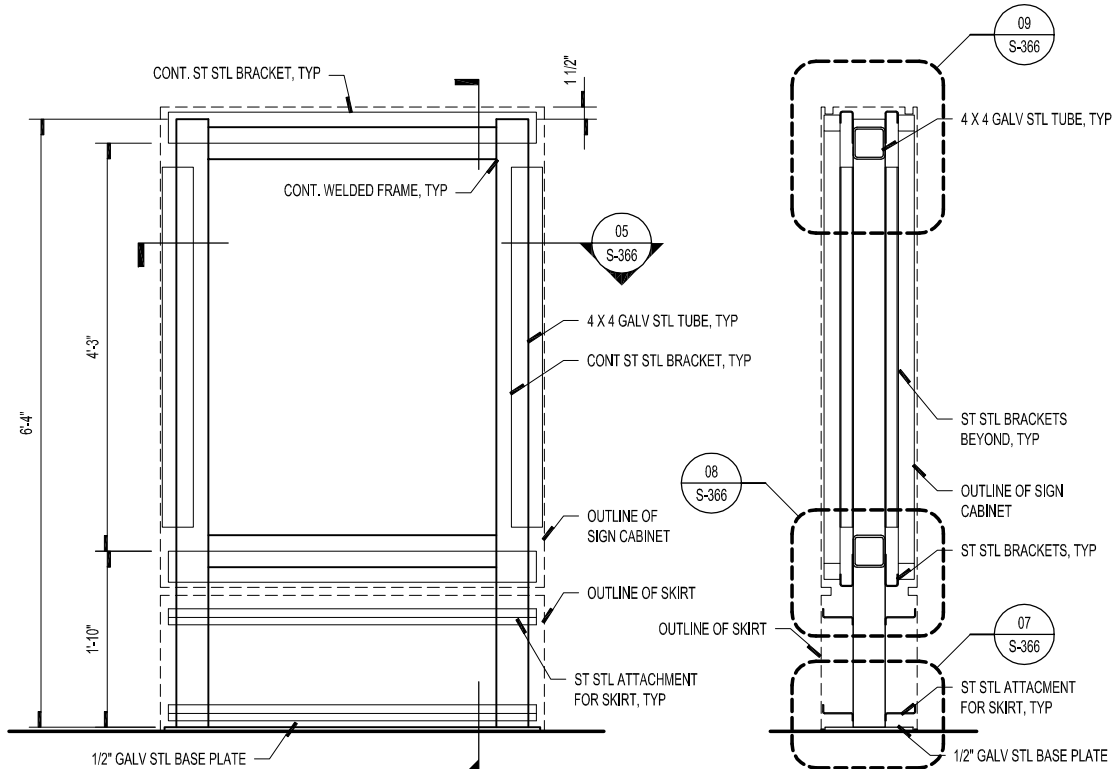

**04 SIGN BOX TYPE S-366**  
INTERNAL STRUCTURE - SECTION

**06 SIGN BOX TYPE S-366**  
INTERNAL STRUCTURE - CROSS SECTION

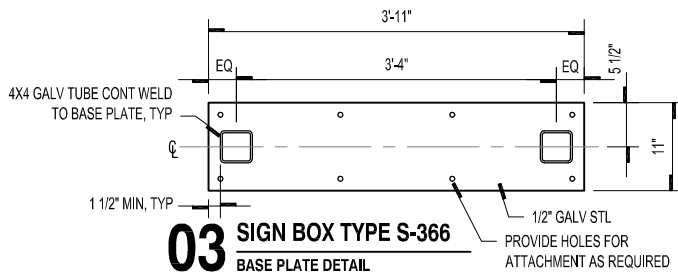

**03 SIGN BOX TYPE S-366**  
BASE PLATE DETAIL

Fabrication Details for Sign Box Type S-366

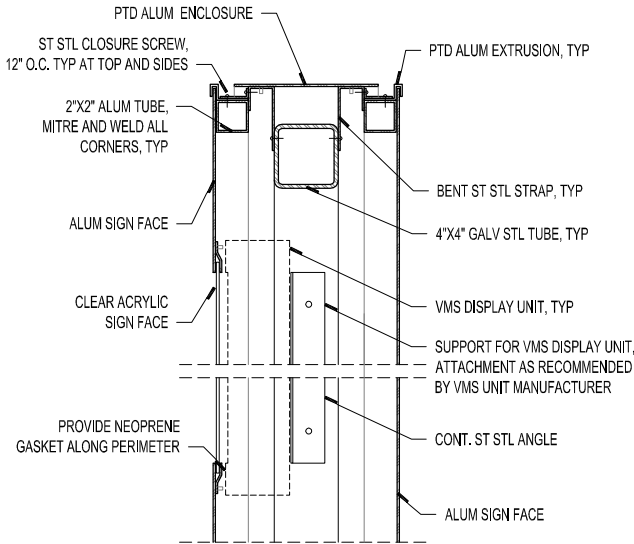

**09** SIGN BOX TYPE S-366  
TOP DETAIL

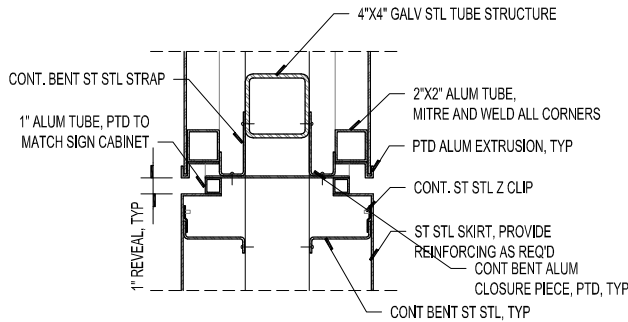

**08** SIGN BOX TYPE S-366  
BOTTOM DETAIL

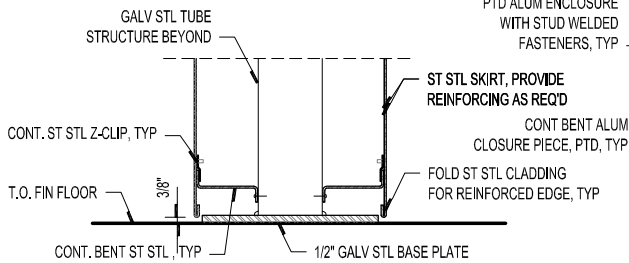

**07** SIGN BOX TYPE S-366  
BASE DETAIL

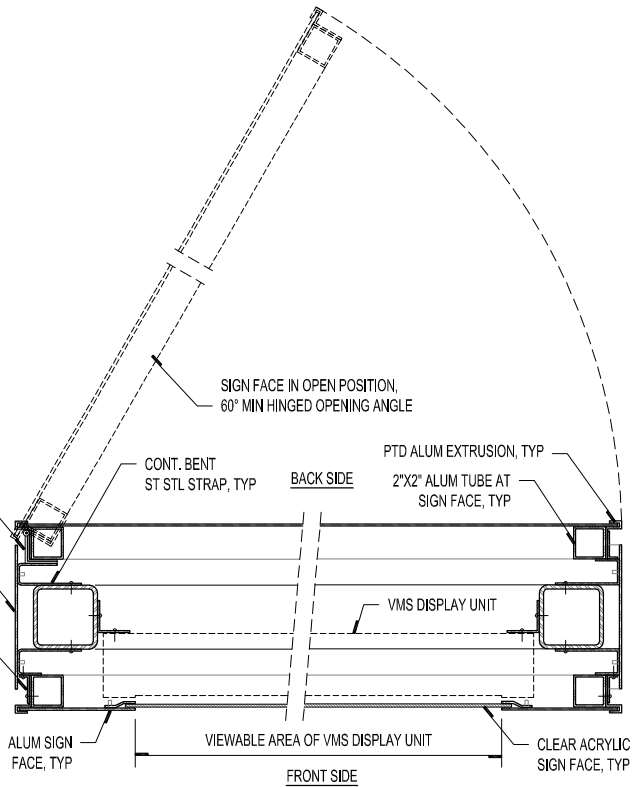

**10** SIGN BOX TYPE S-366  
PLAN / SECTION DETAIL



Details for Sign Box Type S-370

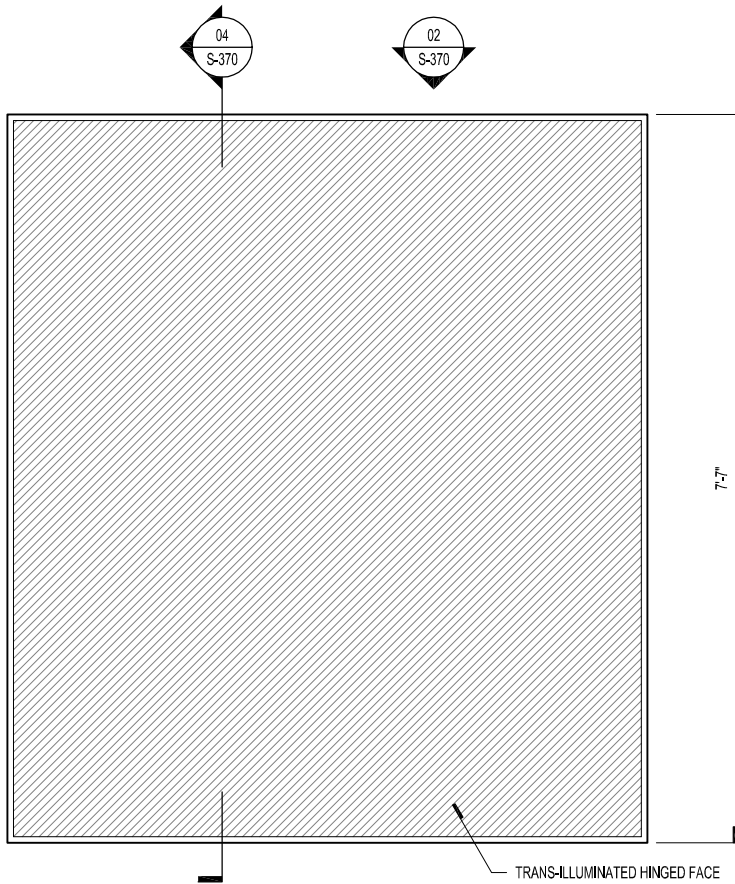
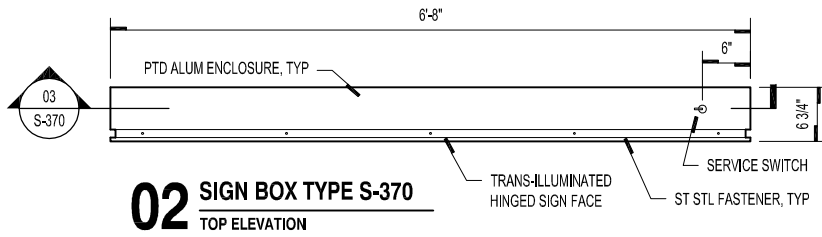

NOTES:

1. ALL CLADDING TO BE WELDED AND GROUND SMOOTH AT CORNERS AND CONNECTIONS.
2. ALL EXPOSED FASTENERS TO BE COUNTERSUNK ST STL.
3. PROVIDE NEMA RATED WATERTIGHT SERVICE SWITCH, LOCATION AS DIRECTED.
4. COORDINATE ELECTRICAL FEEDS. ALL CONDUITS TO ENTER SIGN BOX FROM BACK OF SIGN.
5. PROVIDE WEEP HOLES AT EXTERIOR LOCATIONS. SPACE LED MODULES AS RECOMMENDED BY LED MODULE MANUFACTURER.
6. PROVIDE INTERMEDIATE SUPPORTS AS REQUIRED OR AS RECOMMENDED BY LED MODULE MANUFACTURER. COORDINATE LOCATION OF SUPPORTS WITH LED MODULES TO PROVIDE EVEN ILLUMINATION AVOIDING SHADOWS AND HOT SPOTS.
7. IF SIGN IS MOUNTED WHERE SERVICEABLE WITHOUT A LIFT, PROVIDE CONTINUOUS HINGE AT SIDE INSTEAD OF AT TOP OF SIGN WITH 60° MIN OPENING.
8. PROVIDE PROP ARM AT HINGED SIGN FACE FOR SERVICING.
8. LED MODULES TO BE WEATHERPROOF.

*Fabrication Details for Sign Box Type S-370*

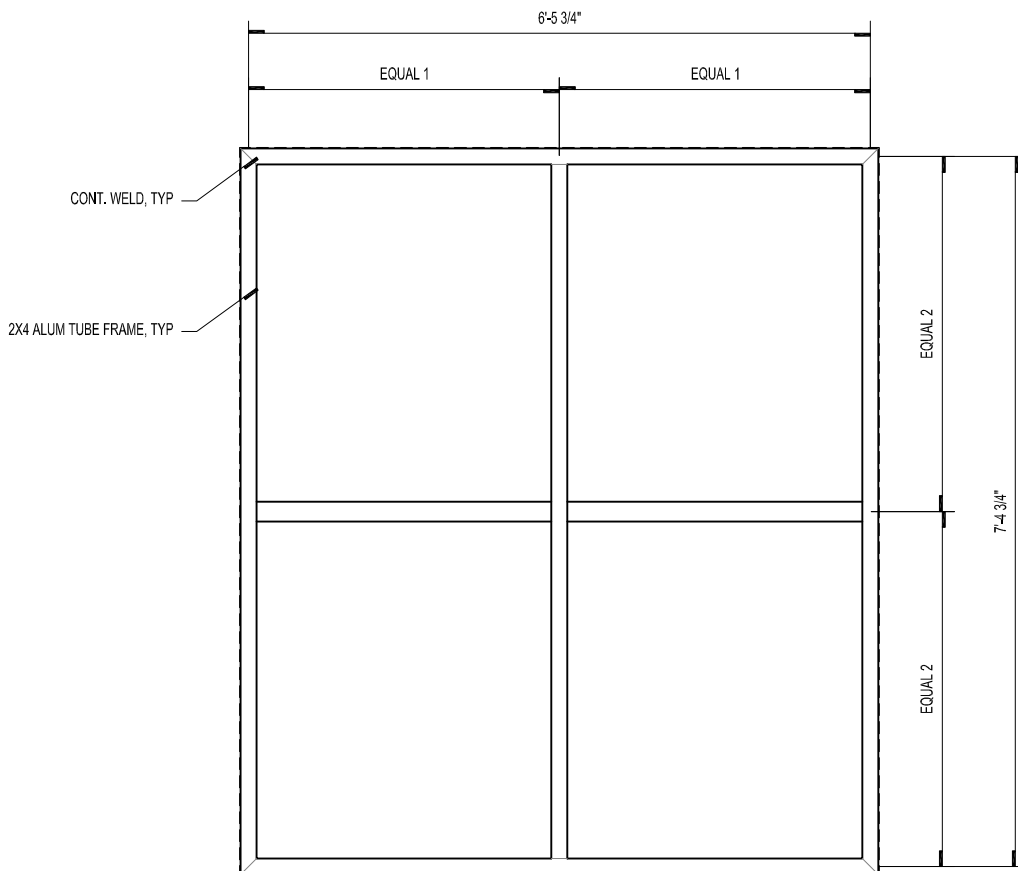

**03** SIGN BOX TYPE S-370  
INTERNAL STRUCTURE - SECTION

*Fabrication Details for Sign Box Type S-370*

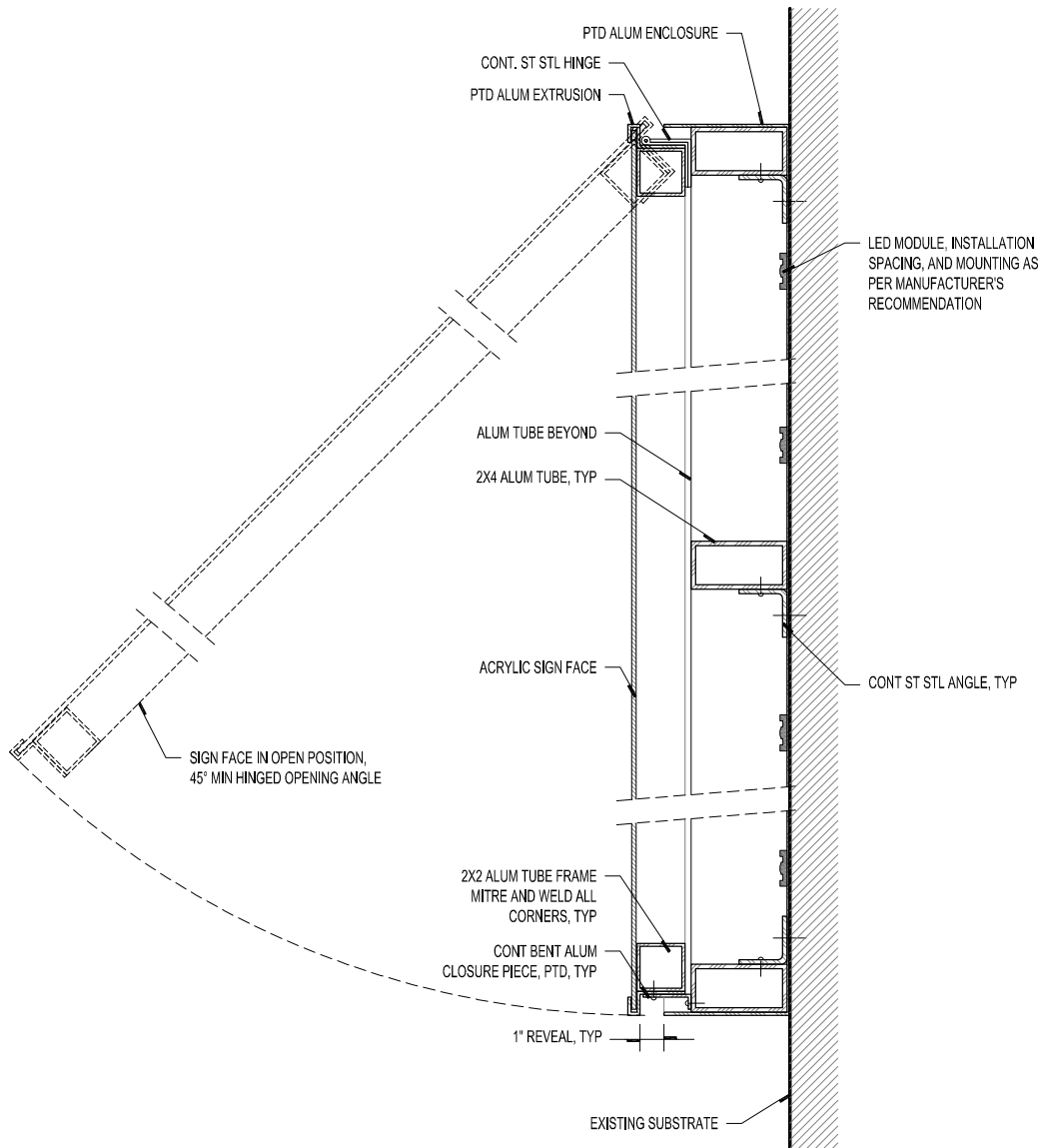

**04** SIGN BOX TYPE S-370  
SECTION DETAIL

## 6.4 ROADWAY SIGN BOXES

Sign Box Types at the Airports' Roadways include:

### ROADWAY SIGN BOXES

Sign Box Type R-1- Overhead Mounted

Sign Box Type R-2 - Cantilever Mounted

Sign Box Type R-3 - Post Mounted

### SPECIALTY SIGN BOXES

Sign Box Type S-452 - Gore

*The drawings shown in this section are available for digital download by clicking on the link on each drawing.*

## Roadway Sign Boxes (Sign Type R)

### Usage and Application

Roadway Sign Boxes are used for the majority of wayfinding signs throughout the airport roadways. They are used for the following sign applications:

#### Primary Messages

- Identification
- Directional
- Informational

#### Secondary Messages

- Identification
- Directional
- Informational

### Methodology

Roadway Sign Boxes consist of an aluminum face that is attached to the roadway structure.

### Mounting Types

There are three ways these sign boxes are mounted:

R-1 is overhead mounted.

R-2 is cantilever mounted.

R-3 is post mounted.

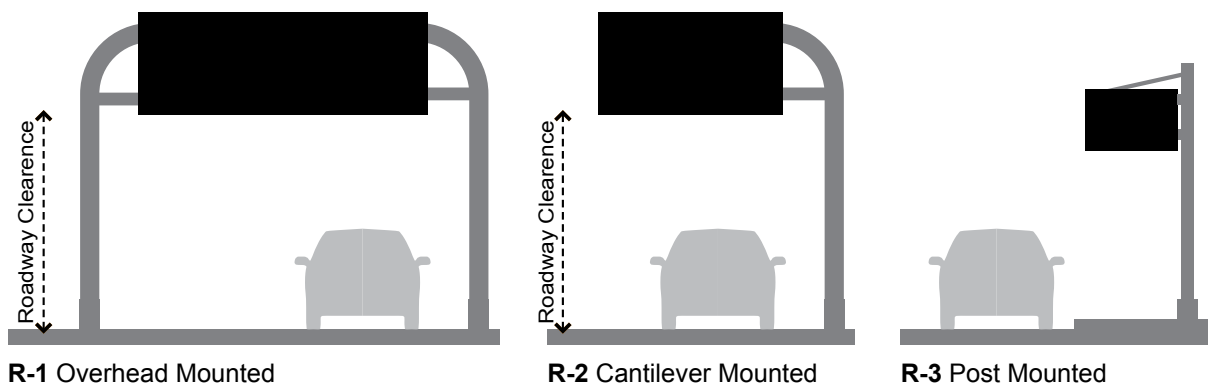

## Specialty Sign Boxes (Sign Type S)

### Usage and Application

Specialty Sign Boxes are used with the following sign applications:

#### Primary Messages

- Identification
- Directional
- Informational

#### Secondary Messages

- Identification
- Directional
- Informational

### Methodology

Specialty Sign Boxes include sign boxes that are either specific to their sign application, require custom fabrication, or will need to be modified based on physical location or current technology available at the time of fabrication.

### Sign Box Type Designation

Because these sign box types are specific to their sign application, the numerical designation for this category corresponds to the Sign Face Type designation shown in Section 5. For example, Sign Box Type S-452 is the sign box for Sign Face ST-452.

### Sign Box Types

**Sign Box Type S-452** is a Gore Sign. This sign is internally illuminated and includes a variable message component (VMS) used to display the list of airlines operating out of the terminal building where it is located. Gore signs are detailed using galvanized steel angles for the structure of the sign that is clad with stainless steel and secured to the structure using stainless steel Z-clips. A portion of the box features an internally illuminated hinged sign face consisting of an acrylic sign face with applied vinyl graphics.

### Mounting Type

These signs are ground mounted.

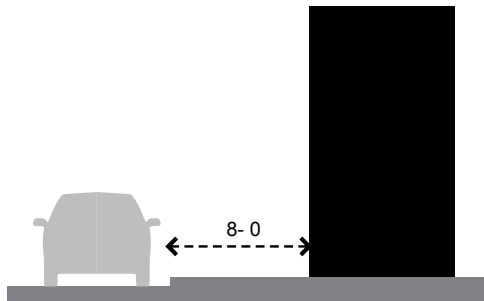

**S-452** Ground Mounted

Specialty Sign Box Drawings

Details for Sign Box Type S-452 - Gore Sign

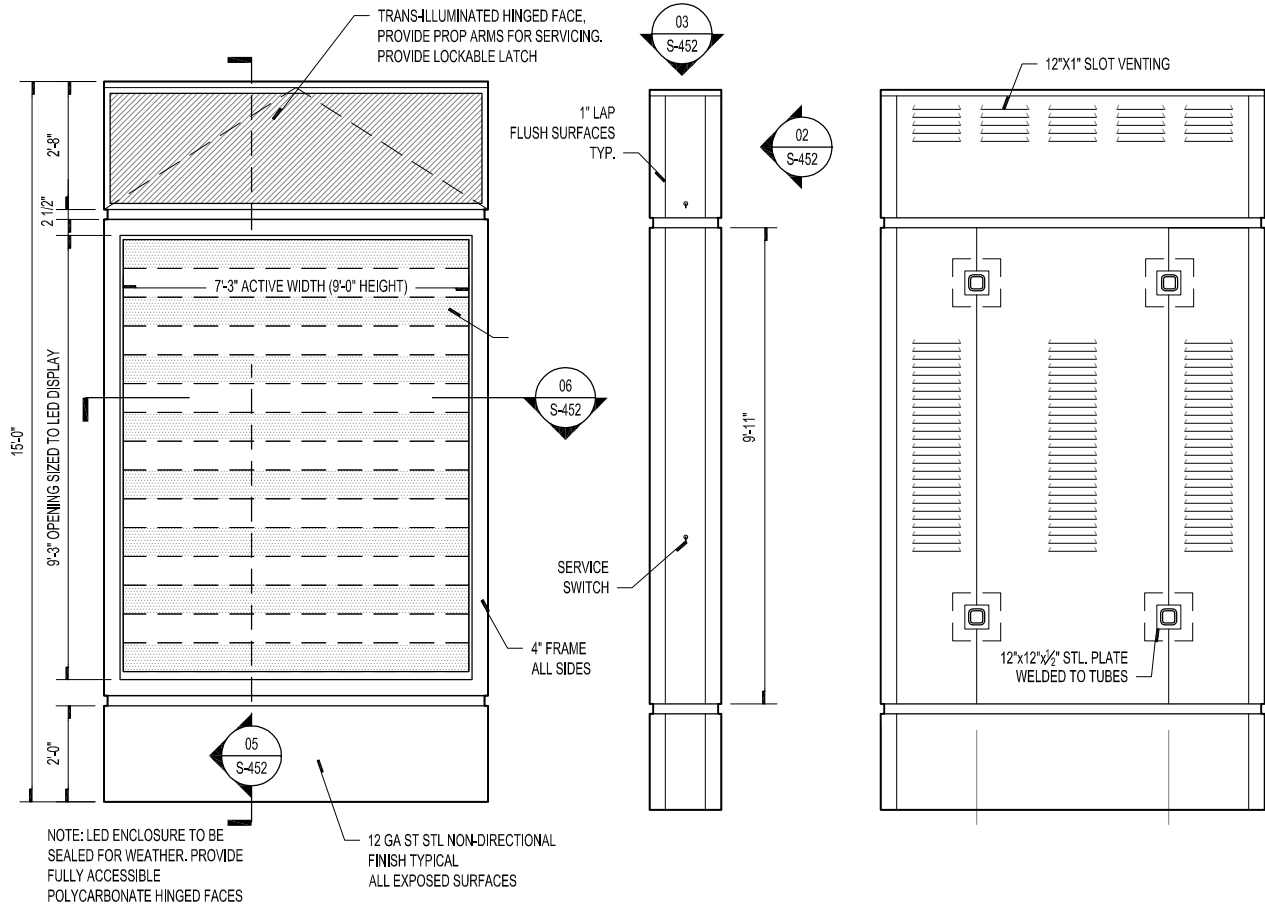

**S-452** INFORMATIONAL GORE SIGN  
SIGN BOX TYPE

**01** SIGN BOX TYPE S-452  
SIDE ELEVATION

**02** SIGN BOX TYPE S-452  
REAR ELEVATION

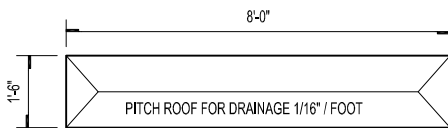

**03** SIGN BOX TYPE S-452  
ROOF PLAN

NOTES

- LED DISPLAY TO BE ENCLOSED IN A THERMALLY CONTROLLED CABINET. PROVIDE HEATERS AND ACTIVE VENTILATION AS REQUIRED TO MAINTAIN ACCEPTABLE OPERATING TEMPERATURES.
- ALL ST STL CLADDING TO BE MITRED AND WELDED AND GROUND SMOOTH AT CORNERS AND CONNECTIONS. NO OPEN FOLDS OR CORNERS.
- ALL EXPOSED ST STL TO BE FINISH NON-DIRECTIONAL.
- ALL EXPOSED FASTENERS TO BE COUNTERSUNK ST STL
- PROVIDE EXTERIOR WATERPROOF SERVICE SWITCH, LOCATION AS DIRECTED.
- COORDINATE ELECTRICAL AND SIGNAL FEEDS. ALL CONDUITS TO ENTER SIGN BOX FROM THE REAR.
- COORDINATE SIGN BOX INTERNAL STRUCTURE WITH EXTERNAL SIGN MOUNTING STRUCTURE, SEE S-500 SERIES.
- MODIFICATION TO SIGN DEPTH MAY BE REQUIRED TO ACCOMMODATE LED DISPLAY CABINET REQUIREMENTS.



**Fabrication Details for Sign Box Type S-452 - Gore Sign**

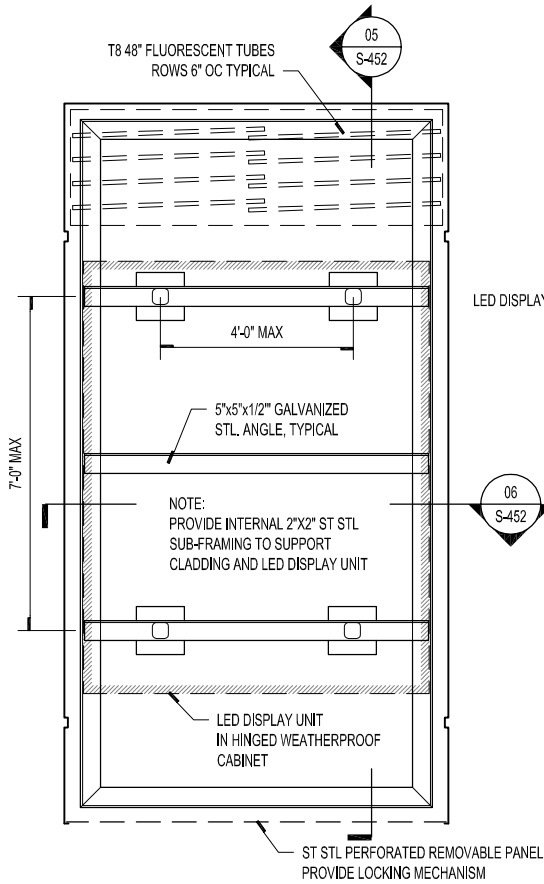

**04** SIGN BOX TYPE S-452  
SECTION

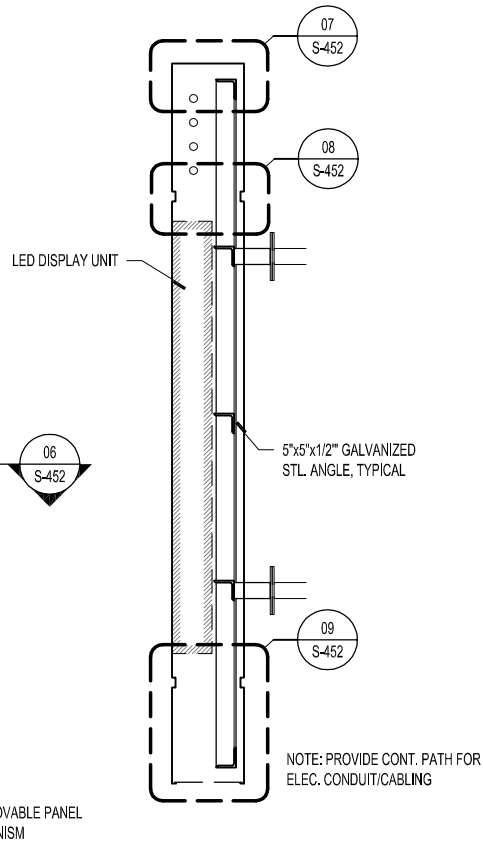

**05** SIGN BOX TYPE S-452  
CROSS SECTION

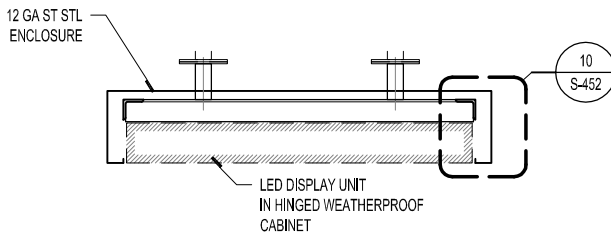

**06** SIGN BOX TYPE S-452  
PLAN / SECTION

**Fabrication Details for Sign Box Type S-452 - Gore Sign**

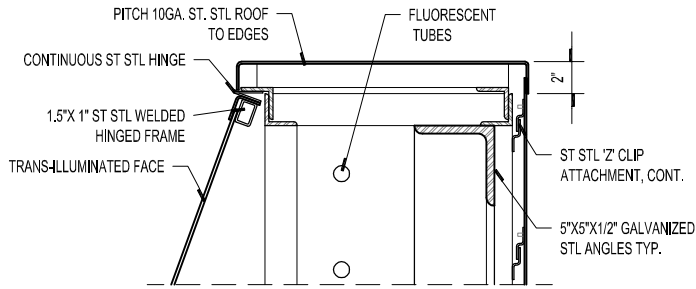

**07 SIGN BOX TYPE S-452**  
TOP DETAIL

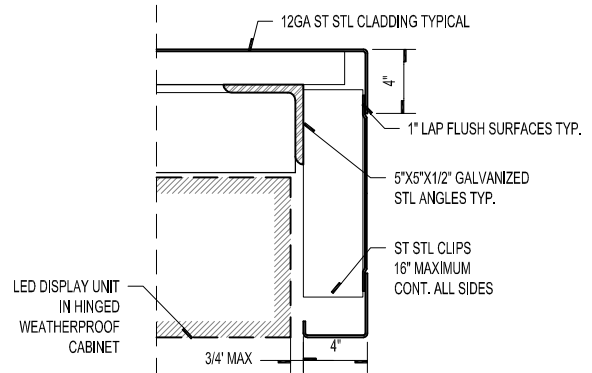

**10 SIGN BOX TYPE S-452**  
PLAN DETAIL

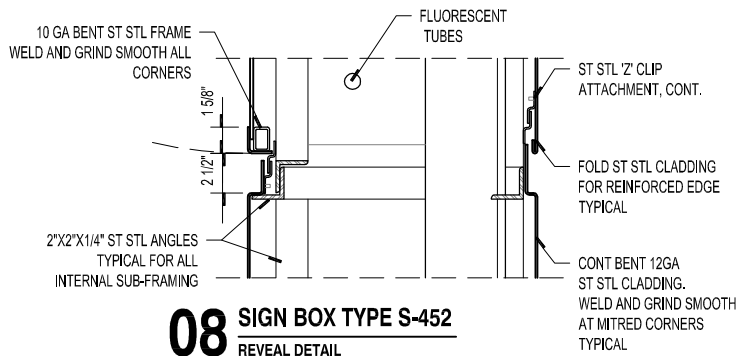

**08 SIGN BOX TYPE S-452**  
REVEAL DETAIL

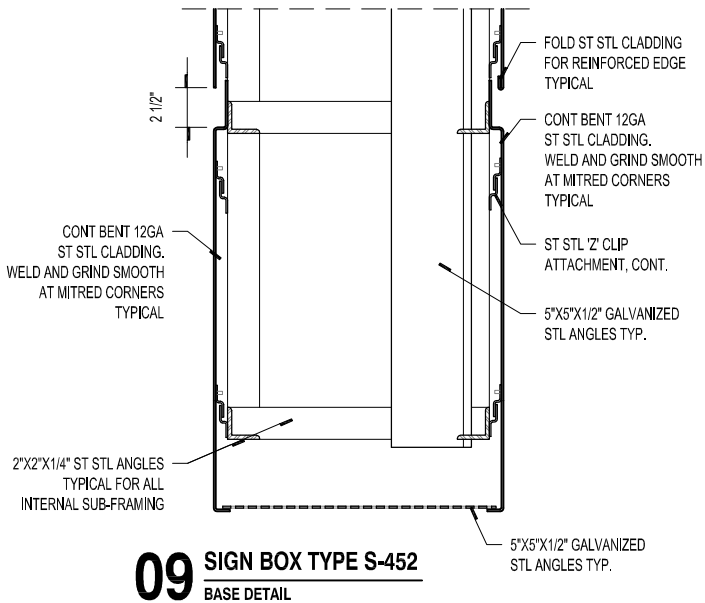

**09 SIGN BOX TYPE S-452**  
BASE DETAIL

## 6.5 AIRPORT SERVICE BUILDING SIGN BOXES

Sign Box Types at Airport Service Buildings include:

### PLAQUES

Sign Box Type G-1 - Plaque - Acrylic Face

### SPECIALTY SIGN BOXES

Sign Box Type S-501 - Vehicular Roadside - Directional

Sign Box Type S-552 - Vehicular Roadside - Building Identification

*The drawings shown in this section are available for digital download by clicking on the link on each drawing.*

## Plaques (Sign Box Type G)

### Usage and Application

Plaques are smaller signs used for secondary messages that are mounted to a wall or surface. They are used with the following sign applications:

Primary Messages	Secondary Messages
<input type="checkbox"/> Identification	<input checked="" type="checkbox"/> Identification
<input type="checkbox"/> Directional	<input type="checkbox"/> Directional
<input type="checkbox"/> Informational	<input type="checkbox"/> Informational

### Methodology

Plaques are detailed using an acrylic face that is attached to an aluminum frame using ultra or very high bond (VHB) adhesive tape. The frame is constructed using aluminum angles and is hidden from view behind the face. The construction of this signs allows the profile to remain thin.

### Mounting

Plaques are single-faced signs mounted to a wall or surface.

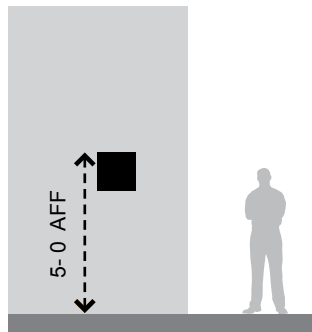

**G** Wall Plaque

### Illumination

This sign box type is not illuminated.

### Sign Box Type Designation

**Sign Box Type G-1** is a surface mounted plaque with a painted acrylic face and applied vinyl graphics. This plaque has an accent header band detail.

Plaques Sign Box Drawings  
 Details for Sign Box Type G-1

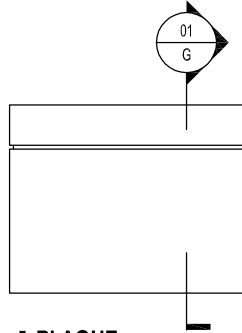

**G-1 PLAQUE**  
 SIGN BOX TYPE  
 NOTE: SEE SECTION 5 FOR SIGN DIMENSIONS

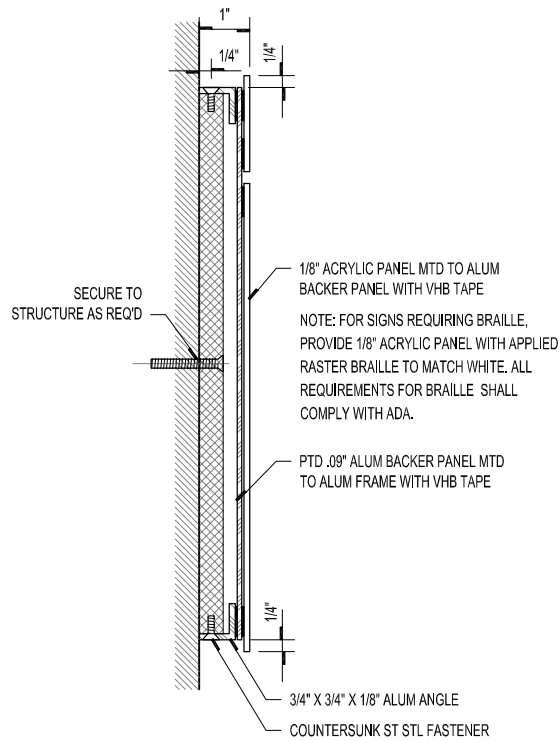

**01 SIGN BOX TYPE G-1**  
 TYPICAL SECTION

## Specialty Sign Boxes (Sign Type S)

### Usage and Application

Specialty Sign Boxes are used with the following sign applications:

#### Primary Messages

- Identification
- Directional
- Informational

#### Secondary Messages

- Identification
- Directional
- Informational

### Methodology

Specialty Sign Boxes include sign boxes that are specific to their sign application.

### Sign Box Type Designation

Because these sign box types are specific to their sign application, the numerical designation for this category corresponds to the Sign Face Type designation shown in Section 5. For example, Sign Box Type S-501 is the sign box for Sign Face ST-501.

### Sign Box Types

**Sign Box Type S-501** is a Vehicular Roadside Directional sign. The sign box type is detailed using a galvanized steel tube frame for the internal structure is clad with galvanized steel panels.

**Sign Box Type S-552** is a Vehicular Roadside Building Identification sign. This sign box type is detailed similar to sign box type S-501. It features a galvanized steel tube frame for the internal structure and is clad with galvanized steel panels.

### Mounting Type

Sign box types S-501 and S-552 are ground mounted.

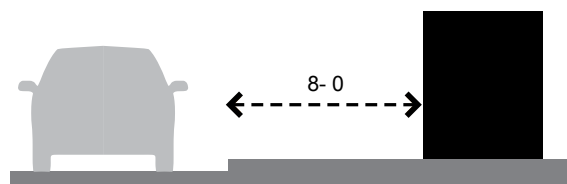

**S-501** Vehicular Roadside Directional Sign

**S-552** Vehicular Roadside Building Identification Sign

Specialty Sign Box Drawings  
 Details for Sign Box Type S-501

NOTES:

1. ALL CLADDING TO BE MITRED AND WELDED AND GROUND SMOOTH AT CORNERS AND CONNECTIONS. NO OPEN FOLDS OR CORNERS.
2. ALL EXPOSED FASTENERS TO BE COUNTERSUNK ST STL.
3. LIMIT OF GRAPHIC ON SIGN FACE TO NOT GO BELOW 1'-4" FROM T.O. GRADE.

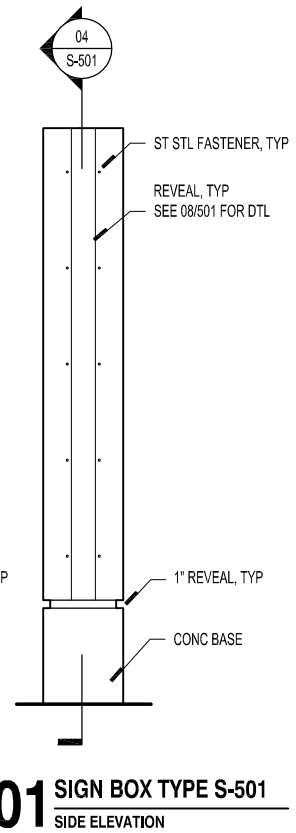
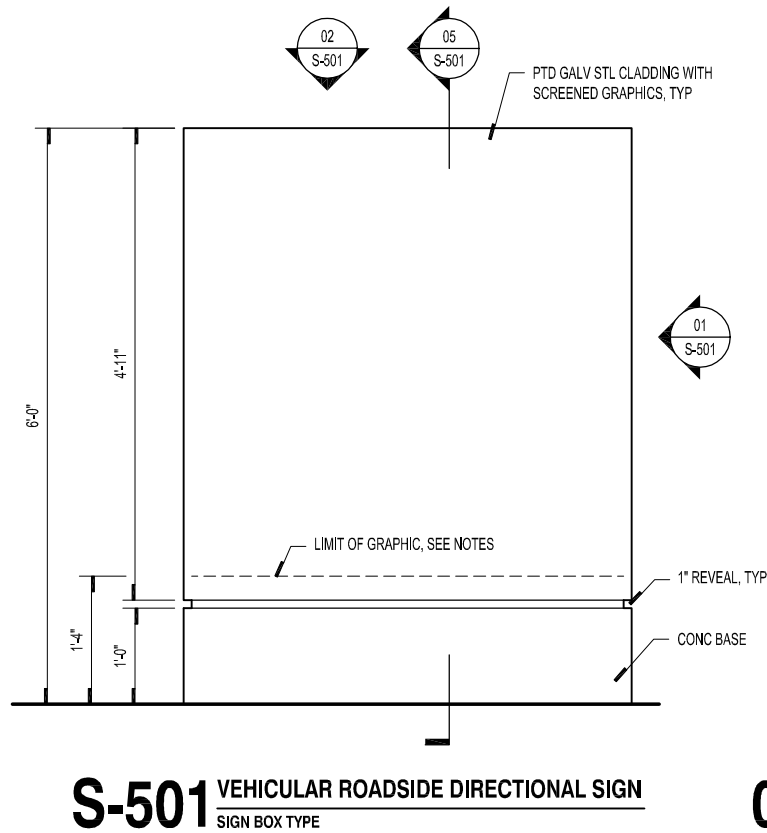
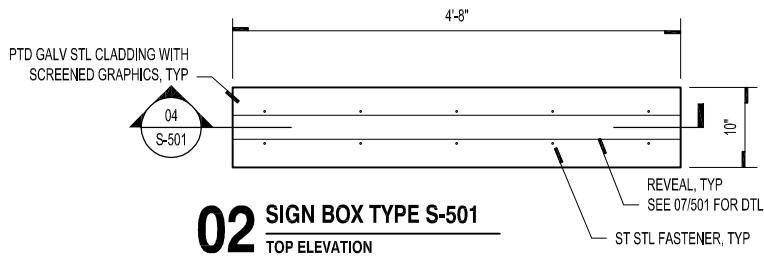

Fabrication Details for Sign Box Type S-501

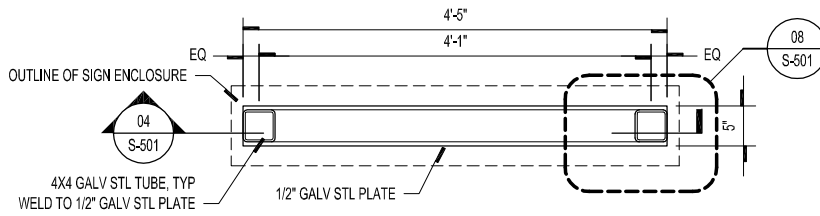

**06** SIGN BOX TYPE S-501  
INTERNAL STRUCTURE - PLAN / SECTION

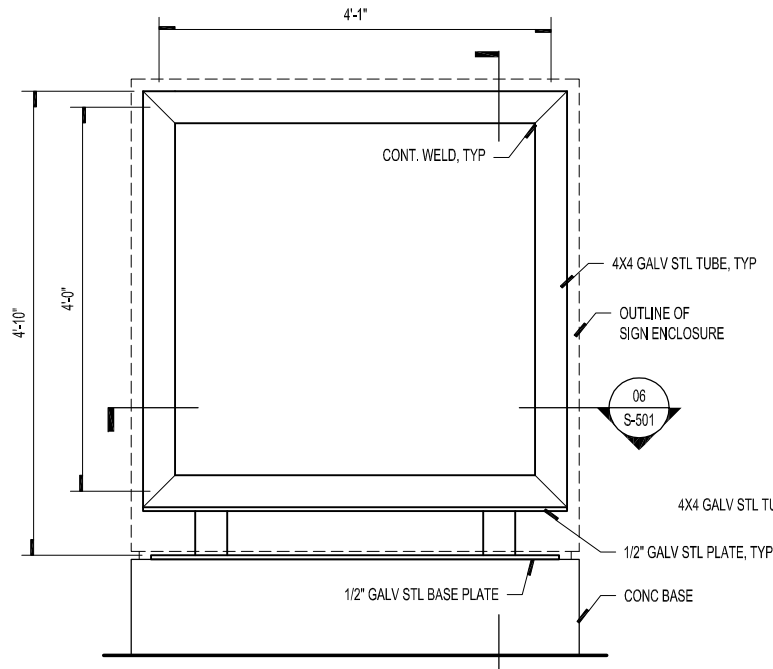

**04** SIGN BOX TYPE S-501  
INTERNAL STRUCTURE - SECTION

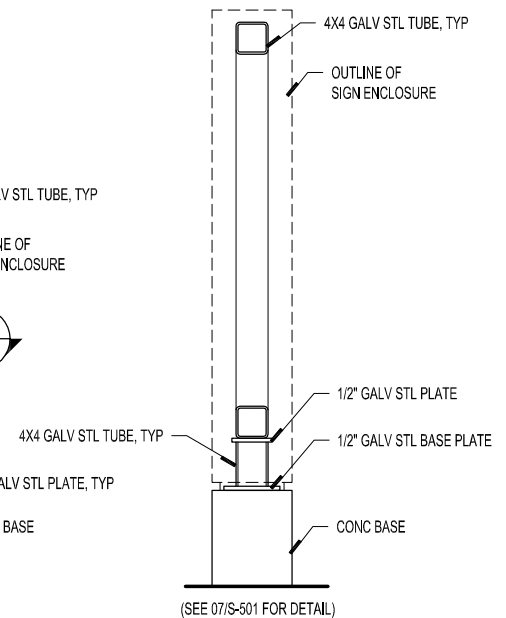

**05** SIGN BOX TYPE S-501  
INTERNAL STRUCTURE - CROSS SECTION

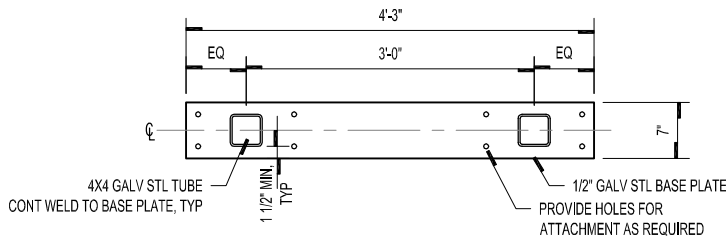

**03** SIGN BOX TYPE S-501  
BASE PLATE DETAIL



**Fabrication Details for Sign Box Type S-501**

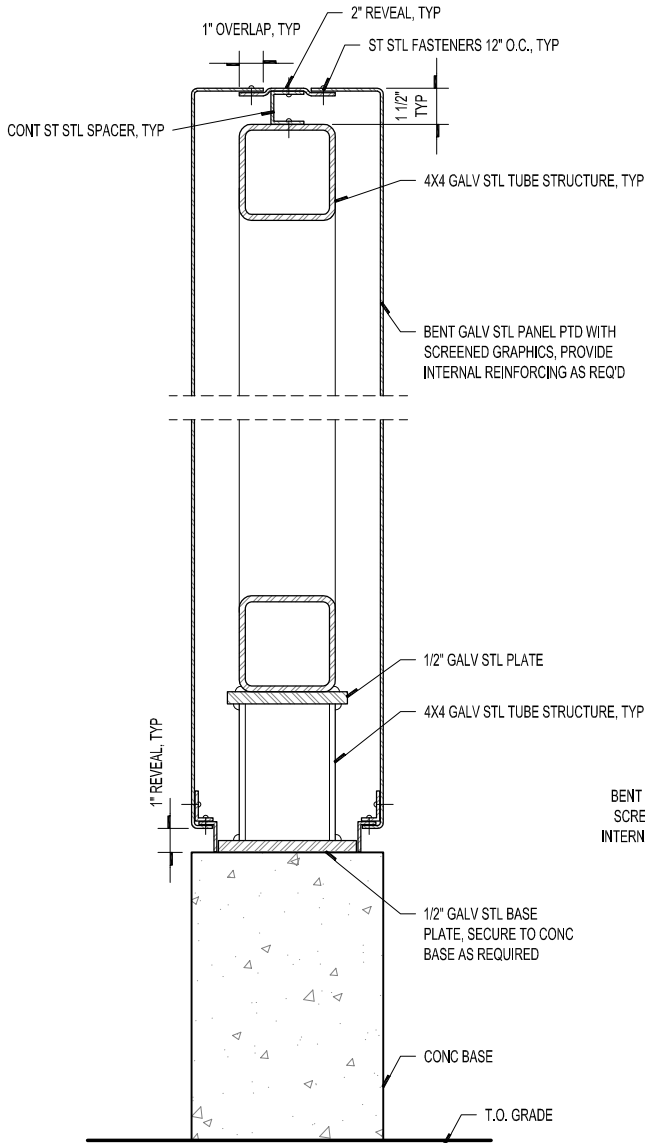

**07** SIGN BOX TYPE S-501  
SECTION DETAIL

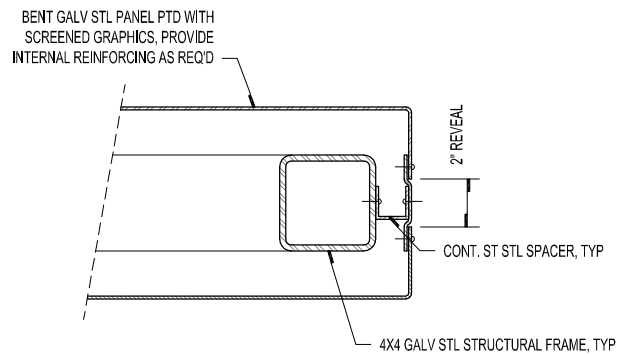

**08** SIGN BOX TYPE S-501  
PLAN / SECTION DETAIL

Details for Sign Box Type S-552

NOTES:

1. ALL CLADDING TO BE MITRED AND WELDED AND GROUND SMOOTH AT CORNERS AND CONNECTIONS. NO OPEN FOLDS OR CORNERS.
2. ALL EXPOSED FASTENERS TO BE COUNTERSUNK ST STL.
3. LIMIT OF GRAPHIC ON SIGN FACE TO NOT GO BELOW 1'-4" FROM T.O. GRADE.

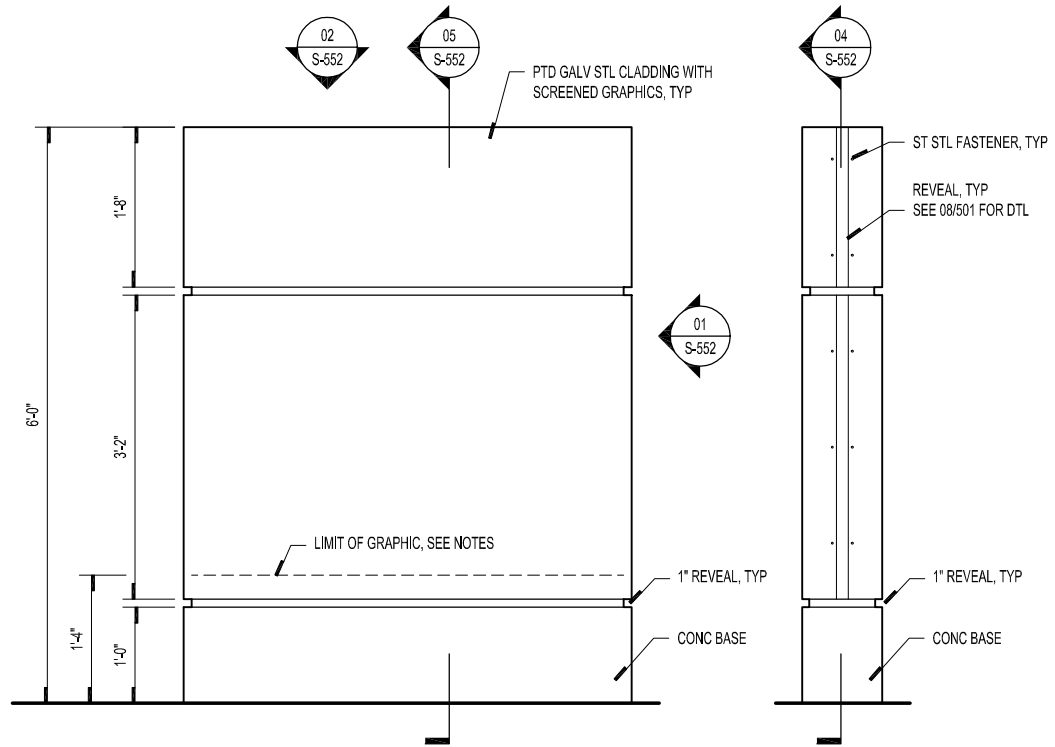
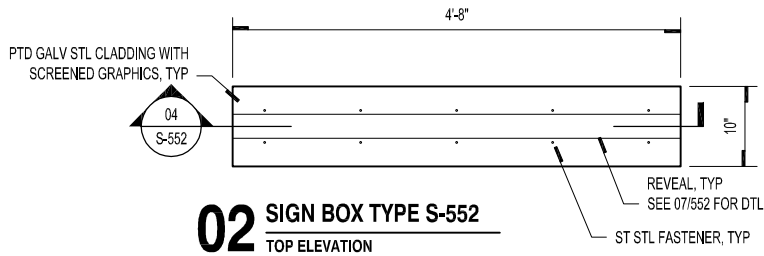

Fabrication Details for Sign Box Type S-552

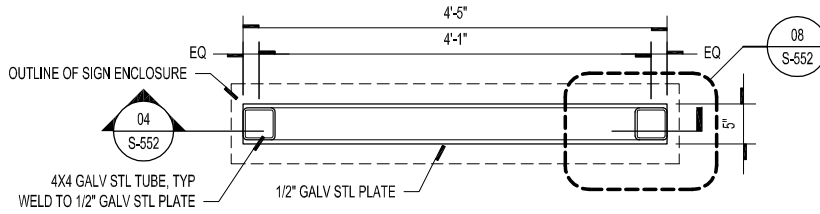

**06** SIGN BOX TYPE S-552  
INTERNAL STRUCTURE - PLAN / SECTION

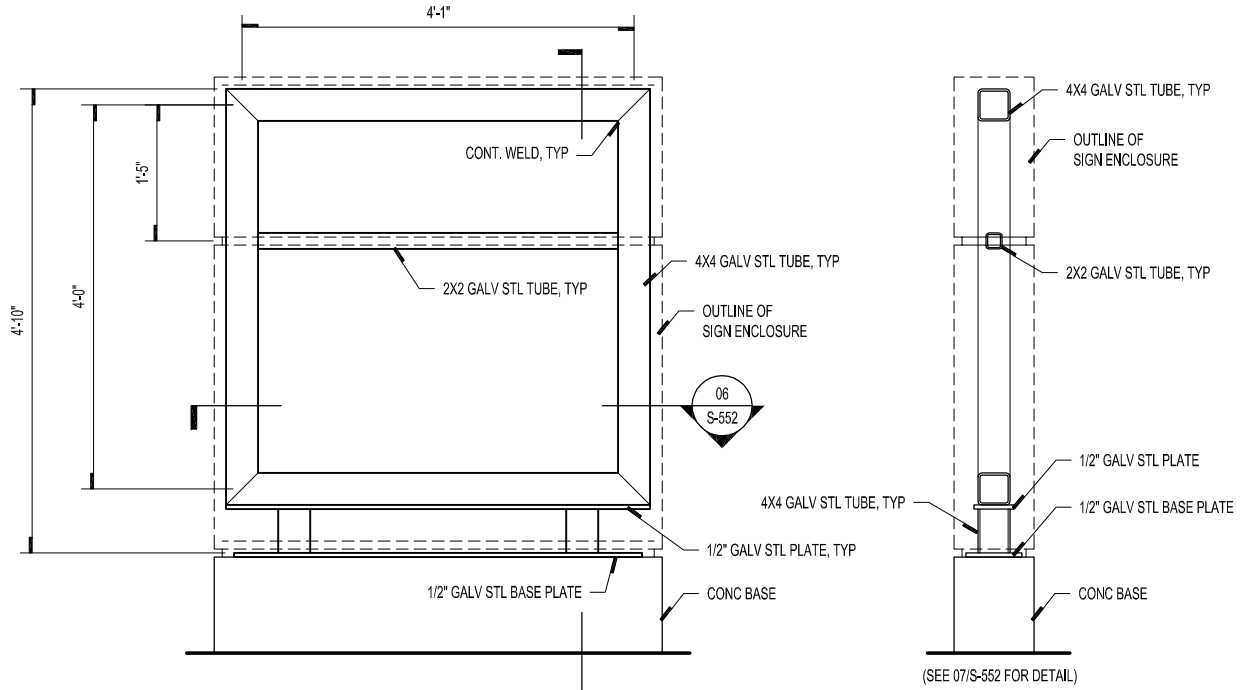

**04** SIGN BOX TYPE S-552  
INTERNAL STRUCTURE - SECTION

**05** SIGN BOX TYPE S-552  
INTERNAL STRUCTURE - CROSS SECTION

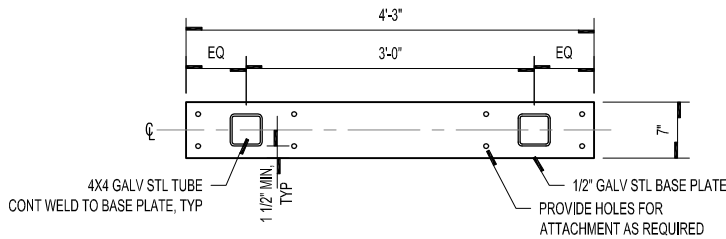

**03** SIGN BOX TYPE S-552  
BASE PLATE DETAIL

**Fabrication Details for Sign Box Type S-552**

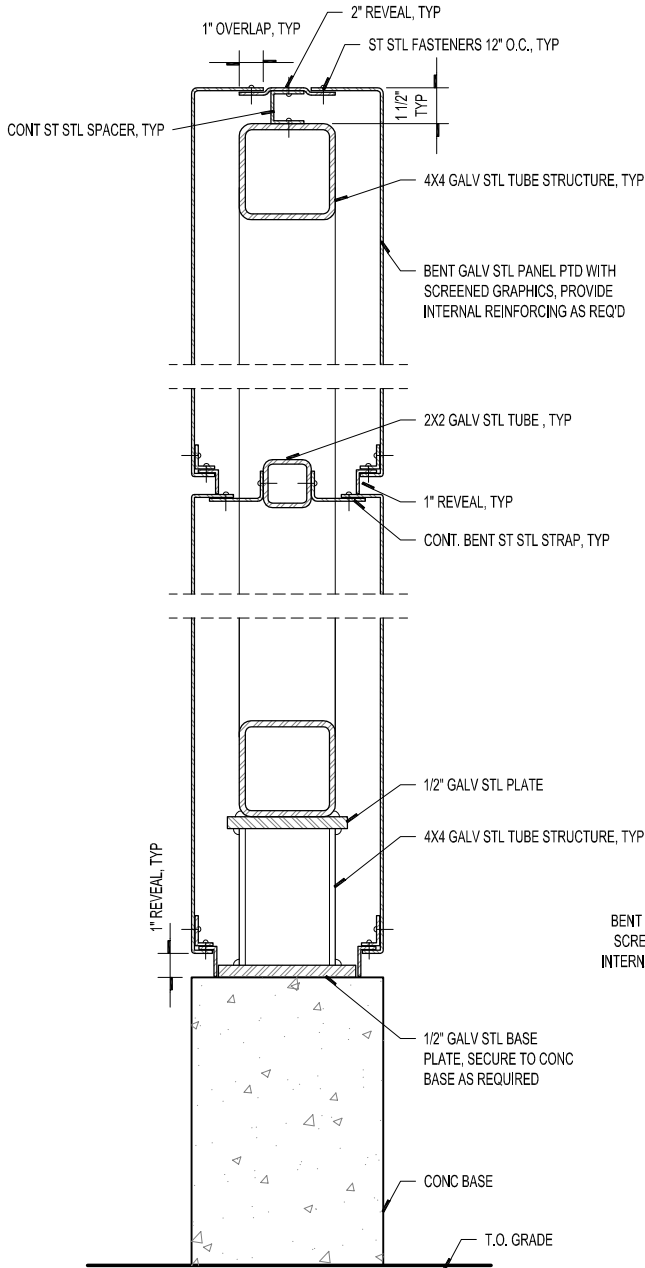

**07** SIGN BOX TYPE S-552  
SECTION DETAIL

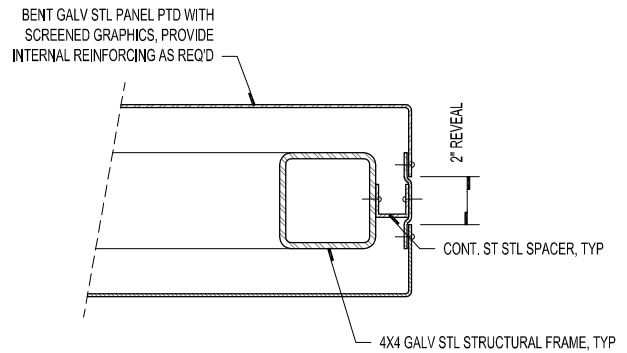

**08** SIGN BOX TYPE S-552  
PLAN / SECTION DETAIL



## **Section 7**

### Additional Guidelines for Tenants

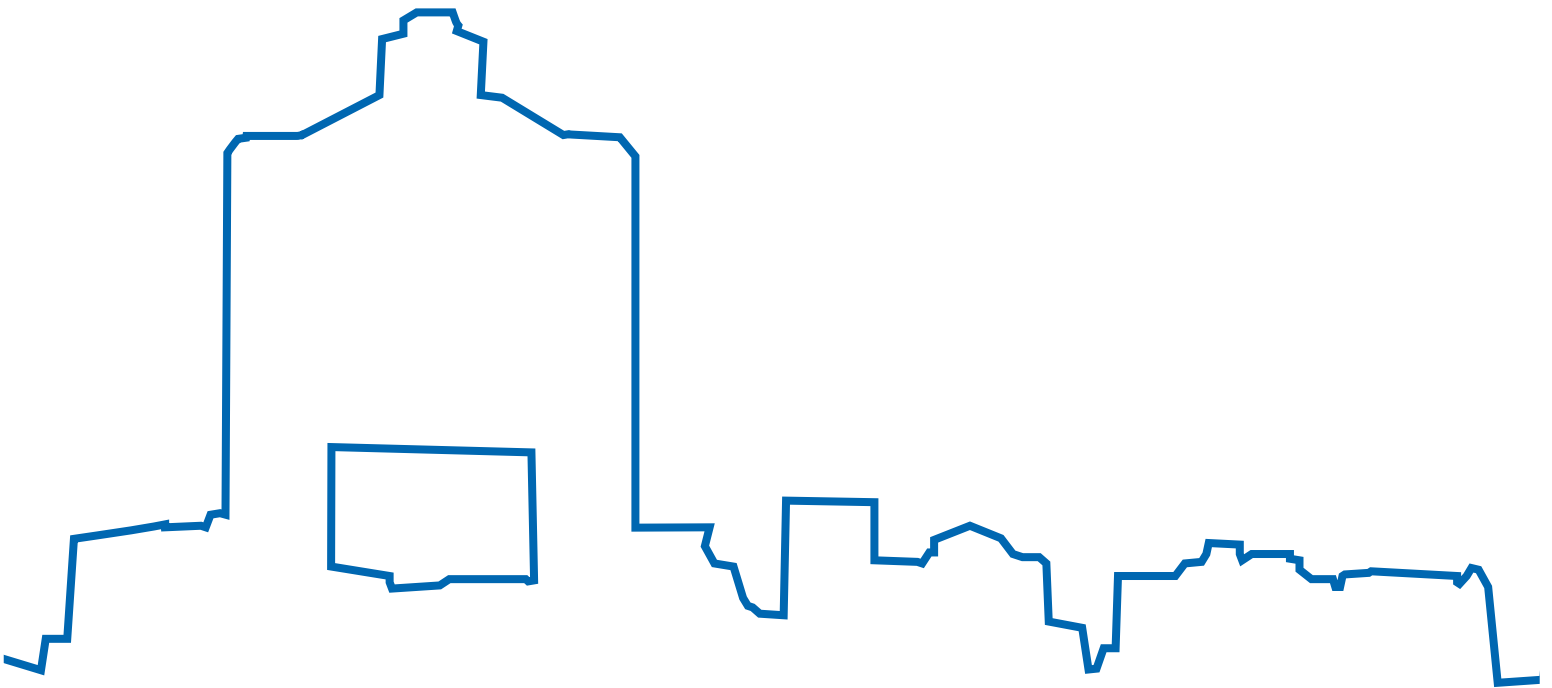

## 7.1 CARGO BUILDINGS

### Design Review Process

Massport will provide one copy of the Guideline and a scale drawing of the building elevation for use by the tenant in preparing a signage submission.

In accordance with Tenant Alteration Application (TAA) requirements, the tenant shall make an application for a sign permit providing four copies of all the sign submittal documents to Massport as required below.

The tenant shall submit corporate graphics standards used for signage to document the relationship between the corporate standards and the signage application for the building.

The tenant shall submit building elevations for proposed signs. Drawings shall be at 1/8" = 1'-0" scale. Each elevation drawing shall include as a minimum:

- Layout on the elevation with dimensions
- Lettering shown to scale with accurate graphic representation of the style and configuration of letters
- Logo (if applicable)
- Color
- Material indications
- Full size drawing of one letter

The tenant shall submit color chip samples for the proposed color of the lettering box panel face and the box enclosure.

The tenant shall submit details indicating methods of fastening to building facade, design of illumination, electrical connections, and sealing from the weather.

The tenant shall submit complete written specifications for all materials, installation methods, and finishes related to proposed signs.

Should the sign for which an application for a permit is made not conform to the Guideline, the sign shall require a Special Permit for Massport. A Special Permit shall be granted only where the Authority finds that to conform to the Signage Guideline would involve substantial hardship or that the requirements of the Guideline can not be met. Application for a Special Permit shall be accompanied by four copies of all the sign submittal documents required.

### Requirements

Building mounted signs shall be the primary identification of companies leasing in Massport at its three airports. No signs or advertising devices of any nature shall be erected to be visible from the exterior except as specifically permitted in this section.

Two types of building mounted signs shall be permitted: large building locator signs mounted on second floor facades and small doorway entry signs mounted above first floor doors.

Consistent sign elements shall be:

- The mounting location on the buildings
- The sign size in relation to the area of the building leased
- Individual letters for building locator signs
- Box signs for doorway entries
- Materials

Variable sign elements shall be:

- Colors
- Type face and style
- Individual logos and corporate identification
- Letter size

All existing non-conforming signs shall be removed and replaced upon either lease renewal, major renovation, or change of tenancy.

Temporary signs will be permitted by Massport for new tenant in cases where the permanent sign installation cannot be approved and installed prior to commencement of operations by the tenant.

Such temporary signs shall be professionally manufactured and made of nonflammable fabric; with screen applied lettering, sign graphics size, anchoring method, and proposed location to be approved by Massport. Fabric and anchoring methods shall be designed for high wind conditions prevalent at Massport's airports.

### **Sign Type ST-561**

- All new corporate identity signage shall be mounted on the building facades in the positions indicated in the drawings that follow.
- All signs shall be fabricated individual letters indicating the corporate name or standard abbreviation.
- A corporate logo shall be permitted in addition to the corporate name.
- All letter and logo signage shall be electrically illuminated letters or logo graphics with internal lighting and translucent face.
- Lettering and logo styles, colors, and layouts shall be in accordance with corporate standards as submitted to Massport.
- All lettering shall be mounted in alignment with the bottom of the Maximum Signage Area indicated in the drawings that follow. Minimum lettering size shall be 2'-0" less than the maximum permitted.
- Each tenant is limited to one sign per building regardless of the area leased.
- Lettering and logo graphics shall be mounted on the existing facade materials in accordance with specifications. Mounting shall be implemented in a manner which minimizes the size and number of fastenings and penetrations of the facade panels.
- Lettering and logo size shall be in proportion to the area of building being leased. As indicated in the drawings that follow, standards for full-building, half-building, and quarter-building leases apply to Buildings 56, 57, 58, 62, and 63. Lettering size standards for full building, half building, 1/3 building, and 1/6 building occupancy apply to building 61.
- The power for the signs will be the responsibility of the tenant. Electric work shall conform with all Massport TAA and Electrical Code requirements.



### Sign Type ST-562 and ST-563

- All new entrance doorway signage shall be mounted on building facades above doorways in positions indicated in the drawings that follow.
- All signs shall consist of a fabricated face panel on a box cabinet, indicating the corporate name or abbreviation.
- A corporate logo sign will not be permitted in addition to corporate name sign.
- Lettering styles, colors, and layouts shall be consistent with corporate standards as submitted to Massport.
- The first tenant in a building shall install its sign at the lowest height shown and subsequent tenants shall install their signs above the previous tenant signs. Lettering shall be centered in the box and be at least 10" high and no more than 12" high.
- Box cabinet signs shall be mounted on the existing facade materials in accordance with the specifications. The mounting shall be implemented in a manner which minimizes the size and number of fastenings and penetrations of the facade panel.
- The sizes of all box cabinet signs, lettering, and logos shall be as described below. As indicated in the drawings that follow, one standard size applies for Buildings 56, 57, 58, 61, 62, and 63.
- The power for the signs shall be made available by Massport to a junction box inside the building at a point nearest the exterior sign location. Circuitry and power shall be reviewed with Massport Engineering. Connecting power through the facade and sealing from the weather are the responsibility of the tenant. All electrical work shall conform to Electrical Code requirements and Massport TAA requirements.

### Drawings

Elevations with location and size of corporate identification signing areas are included for the majority of the South Cargo Buildings. Designers shall confirm signing area with Massport for Cargo Buildings not included in this document.

**ST-561 CARGO BUILDINGS - IDENTIFICATION**  
**BUILDING 56 - SINGLE TENANT**

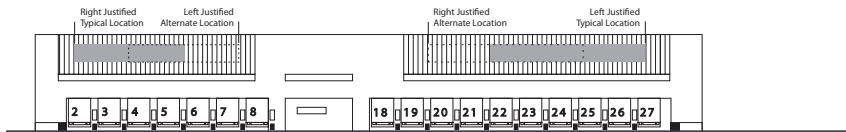

OVERALL ELEVATION - BUILDING 56: Single Tenant per section  
 Scale: N. T. S.

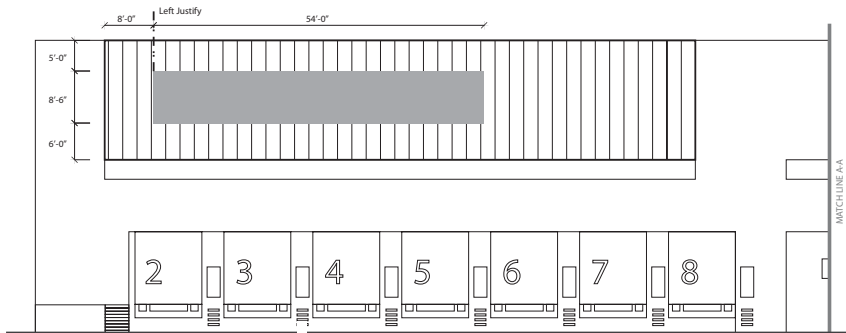

PARTIAL ELEVATION - BUILDING 56  
 Scale: N. T. S

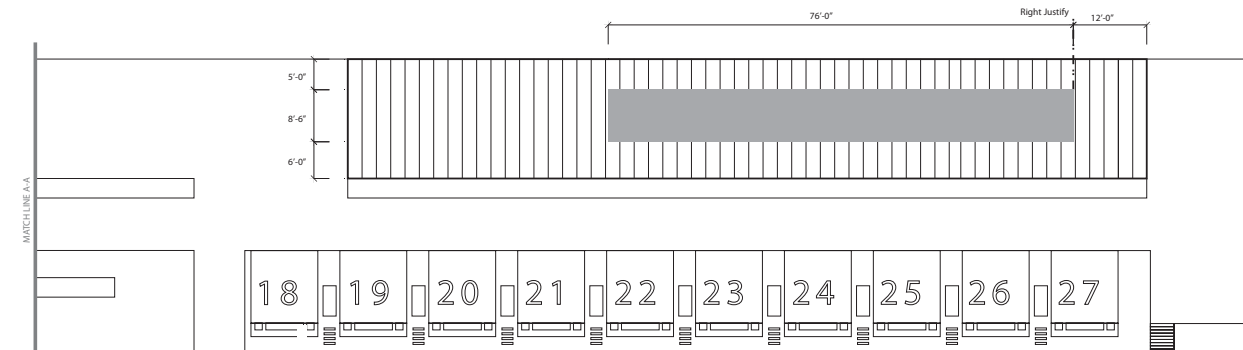

PARTIAL ELEVATION - BUILDING 56  
 Scale: N. T. S.

SECTION 7 ADDITIONAL GUIDELINES FOR TENANTS

ST-561 CARGO BUILDINGS - IDENTIFICATION

BUILDING 56 - MULTIPLE TENANTS

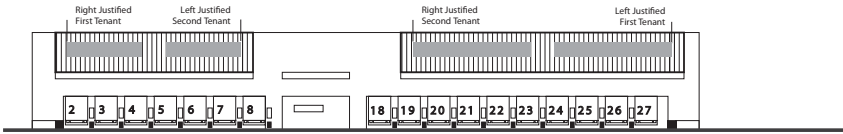

OVERALL ELEVATION - BUILDING 56: Multiple Tenants per section

Scale: N. T. S.

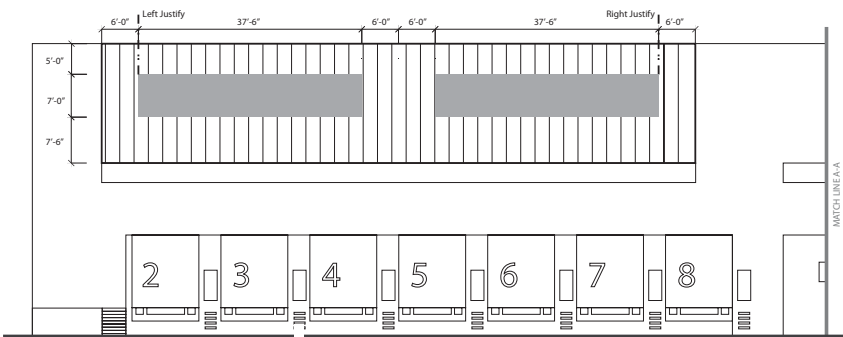

PARTIAL ELEVATION - BUILDING 56

Scale: N. T. S.

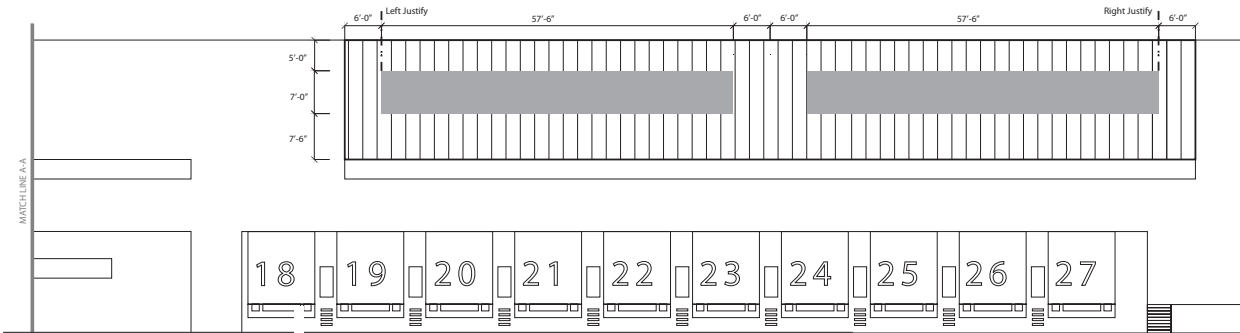

PARTIAL ELEVATION - BUILDING 56

Scale: N. T. S.

**ST-561 CARGO BUILDINGS - IDENTIFICATION**  
**BUILDINGS 57 AND 58 - SINGLE TENANT**

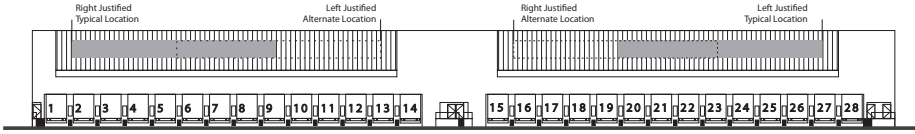

OVERALL ELEVATION - BUILDING 57 and 58: Single Tenant per section

Scale: N. T. S.

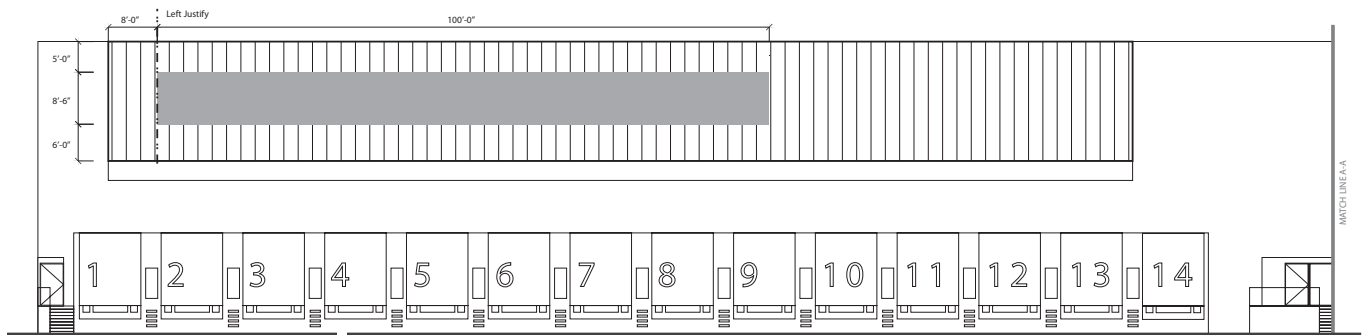

PARTIAL ELEVATION - BUILDING 57 and 58

Scale: N. T. S.

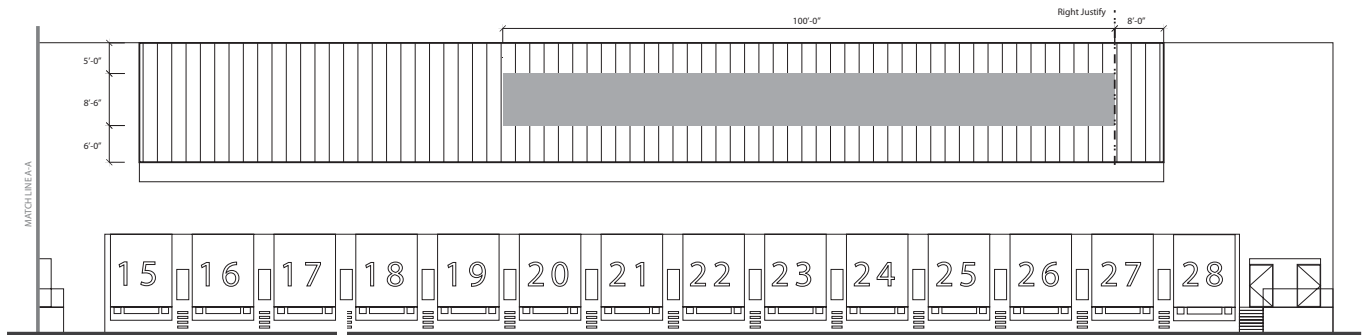

PARTIAL ELEVATION - BUILDING 57 and 58

Scale: N. T. S.



**ST-561 CARGO BUILDINGS - IDENTIFICATION**  
**BUILDINGS 57 AND 58 - MULTIPLE TENANTS**

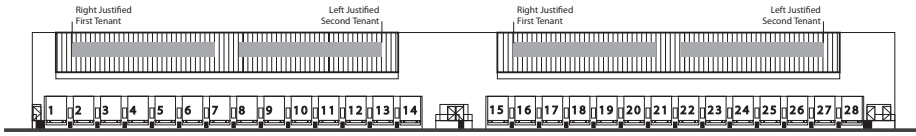

OVERALL ELEVATION - BUILDING 57 and 58: Multiple Tenants per section  
 Scale: N. T. S.

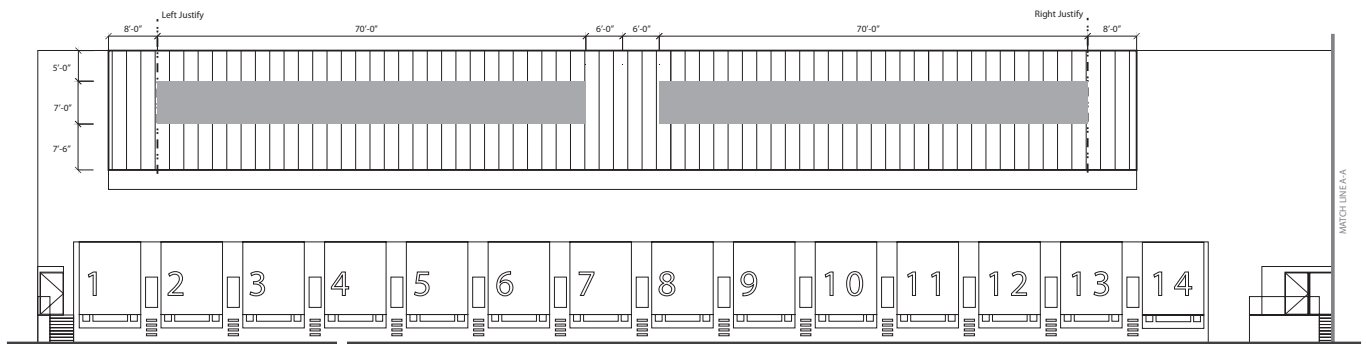

PARTIAL ELEVATION - BUILDING 57 and 58  
 Scale: N. T. S.

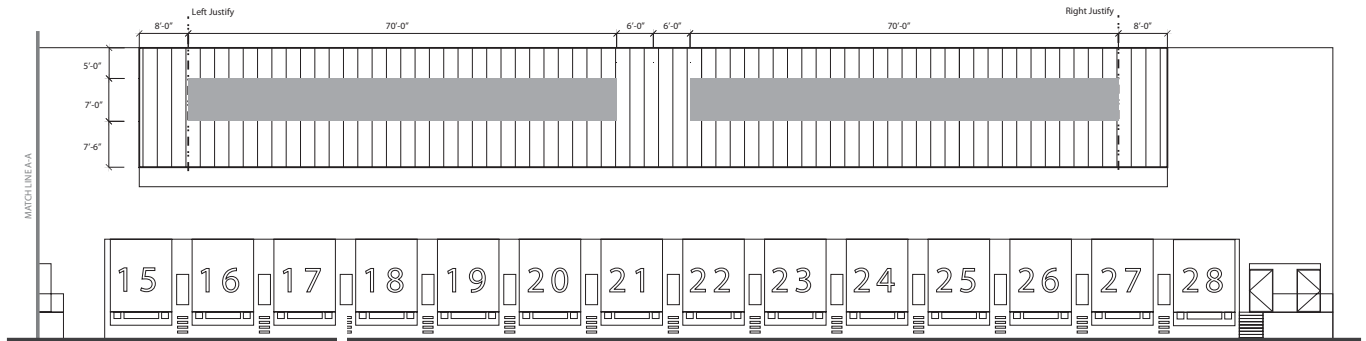

PARTIAL ELEVATION - BUILDING 57 and 58  
 Scale: N. T. S.

ST-561 CARGO BUILDINGS - IDENTIFICATION

BUILDING 61 - SINGLE TENANT

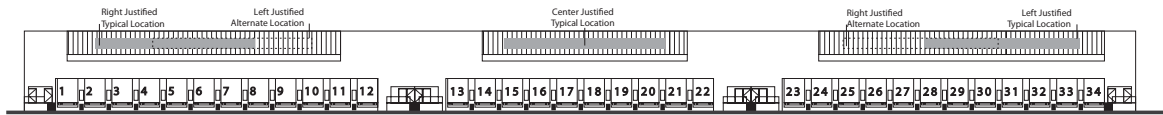

OVERALL ELEVATION - BUILDING 61: Single Tenant per section

Scale: N. T. S.

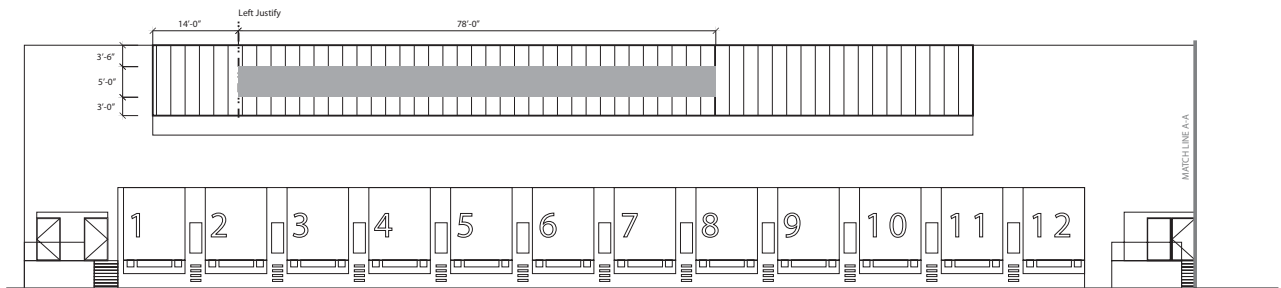

PARTIAL ELEVATION - BUILDING 61

Scale: N. T. S.

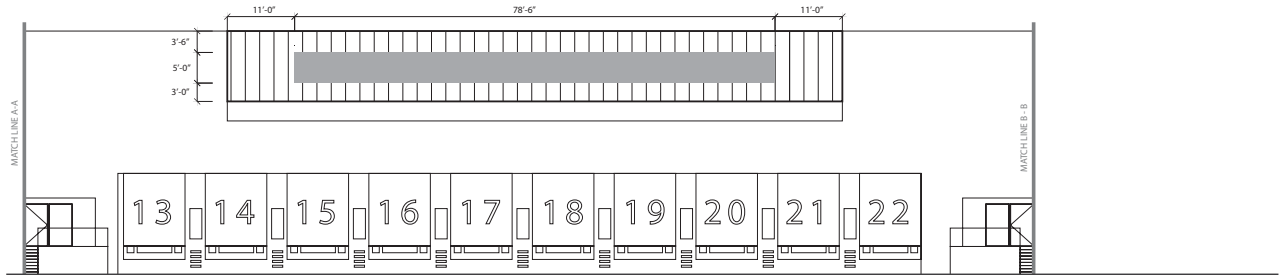

PARTIAL ELEVATION - BUILDING 61

Scale: N. T. S.

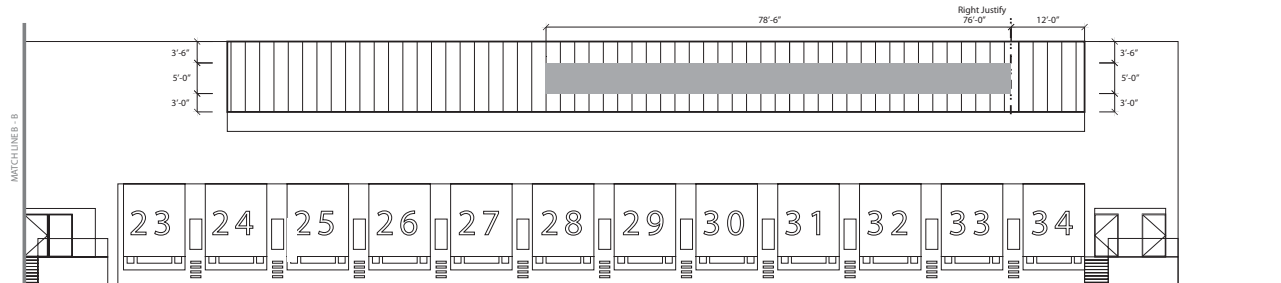

PARTIAL ELEVATION - BUILDING 61

Scale: N. T. S.



ST-561 CARGO BUILDINGS - IDENTIFICATION

BUILDING 61 - MULTIPLE TENANTS

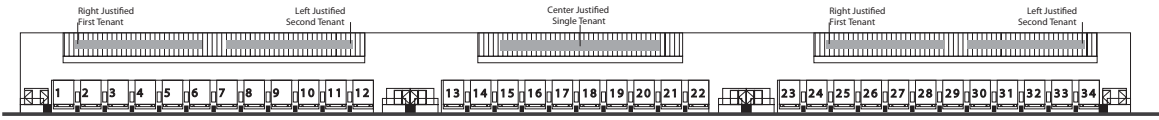

OVERALL ELEVATION - BUILDING 61: Multiple Tenants per section

Scale: N. T. S.

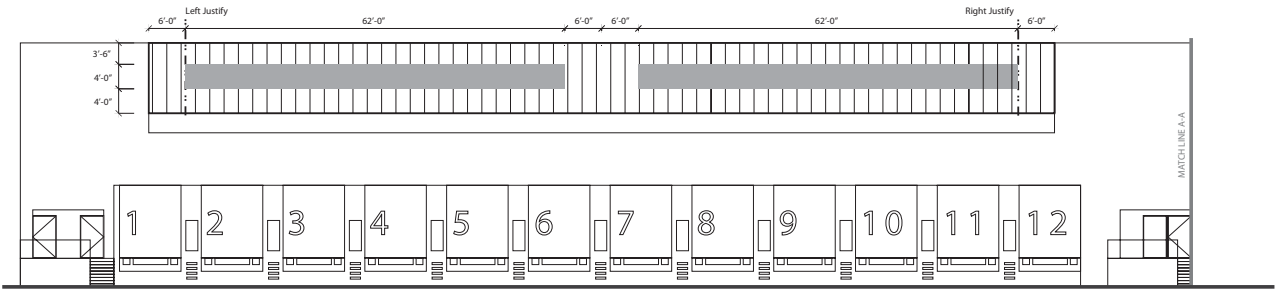

PARTIAL ELEVATION - BUILDING 61

Scale: N. T. S.

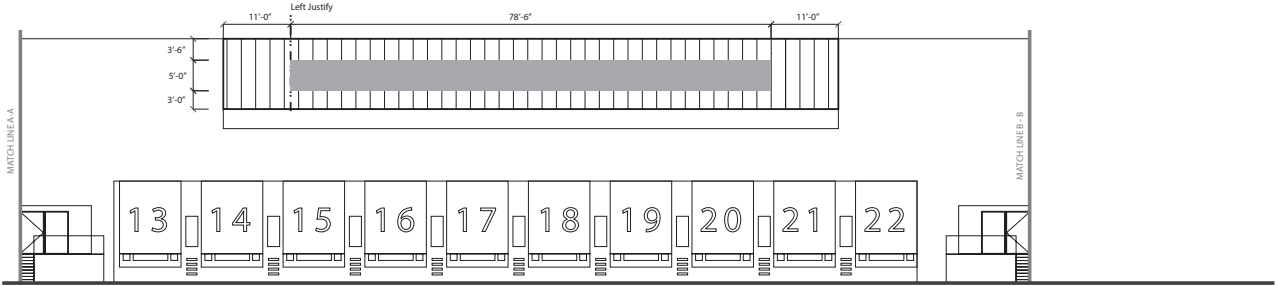

PARTIAL ELEVATION - BUILDING 61

Scale: N. T. S.

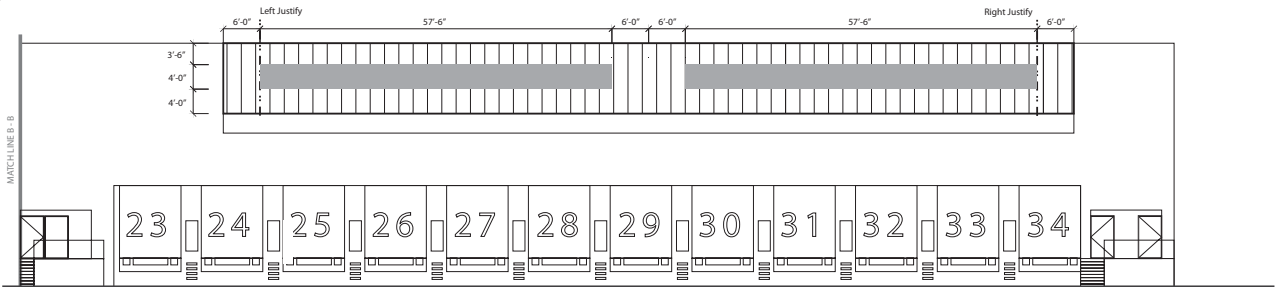

PARTIAL ELEVATION - BUILDING 61

Scale: N. T. S.



**ST-561 CARGO BUILDINGS - IDENTIFICATION**  
**BUILDING 62 - SINGLE TENANT**

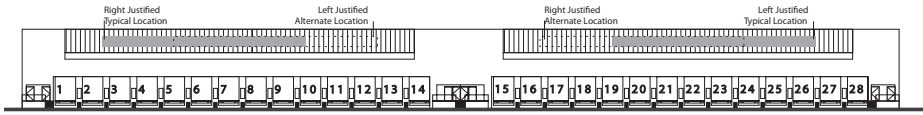

OVERALL ELEVATION - BUILDING 62: Single Tenant per section  
 Scale: N. T. S.

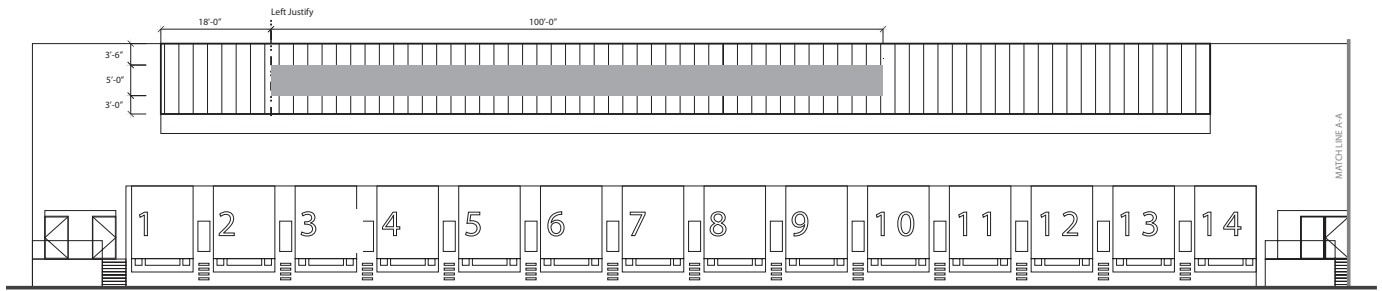

PARTIAL ELEVATION - BUILDING 62  
 Scale: N. T. S.

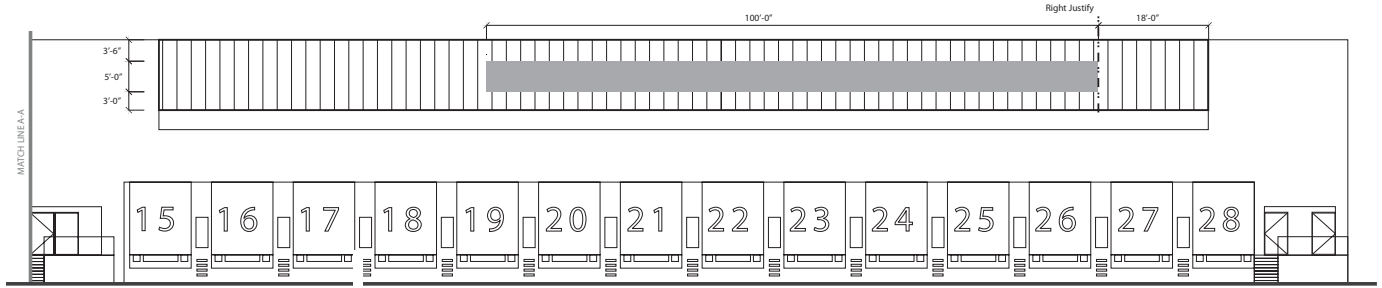

PARTIAL ELEVATION - BUILDING 62  
 Scale: N. T. S.





**ST-561 CARGO BUILDINGS - IDENTIFICATION**  
**BUILDING 62 - MULTIPLE TENANTS**

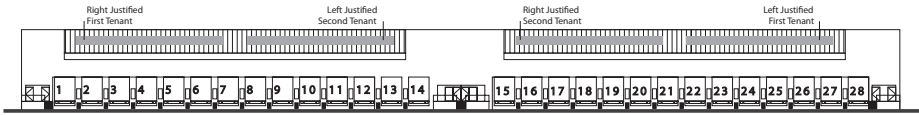

OVERALL ELEVATION - BUILDING 62: Multiple Tenant per section  
 Scale: N. T. S.

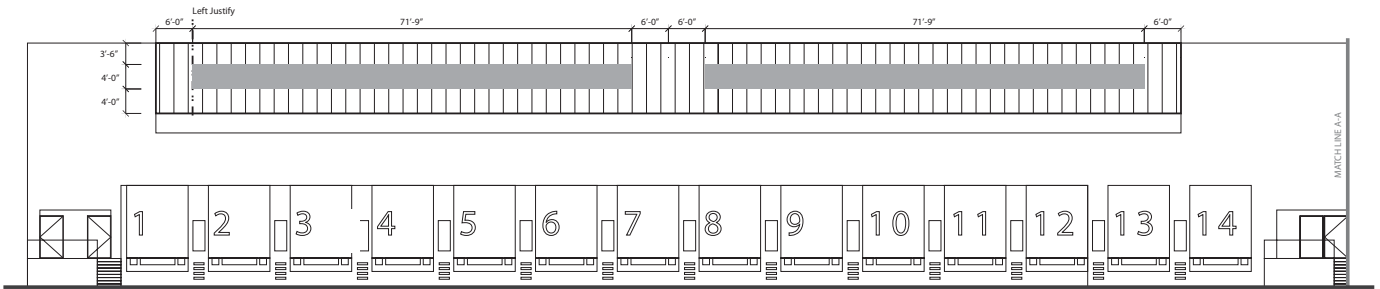

PARTIAL ELEVATION - BUILDING 62  
 Scale: N. T. S.

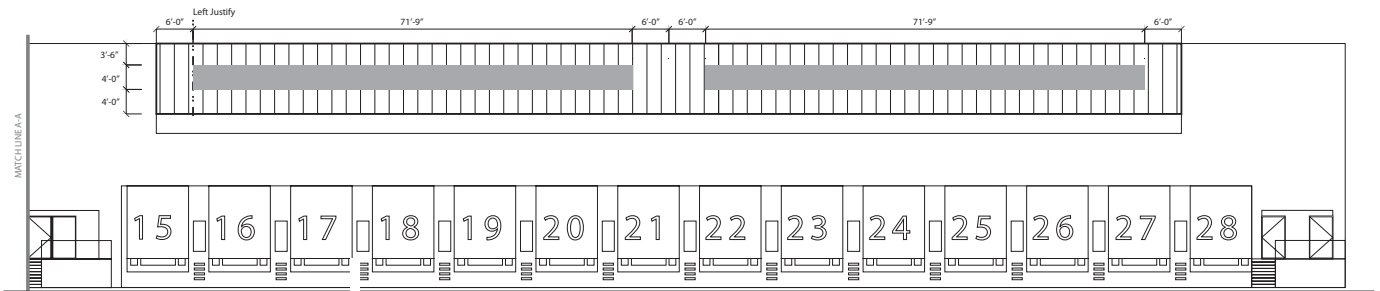

PARTIAL ELEVATION - BUILDING 62  
 Scale: N. T. S.

ST-562 CARGO BUILDINGS - IDENTIFICATION  
**BUILDING 56**



SIGNING AREA LAYOUT  
 Scale: 3/8"=1'-0"

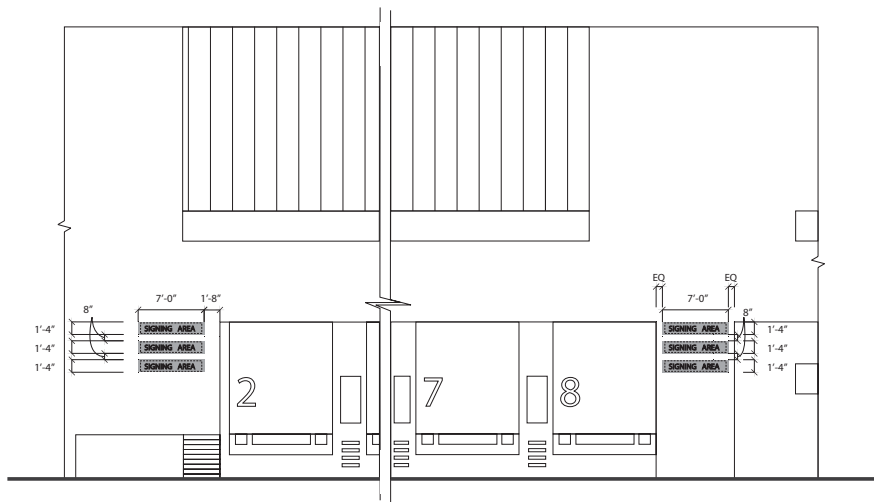

PARTIAL ELEVATION - BUILDING 56  
 Scale: N. T. S.

ST-563 CARGO BUILDINGS - IDENTIFICATION  
BUILDINGS 57, 58, 61 AND 62

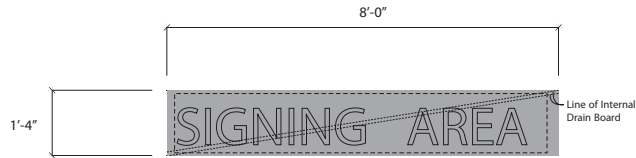

SIGNING AREA LAYOUT  
Scale: 3/8"=1'-0"

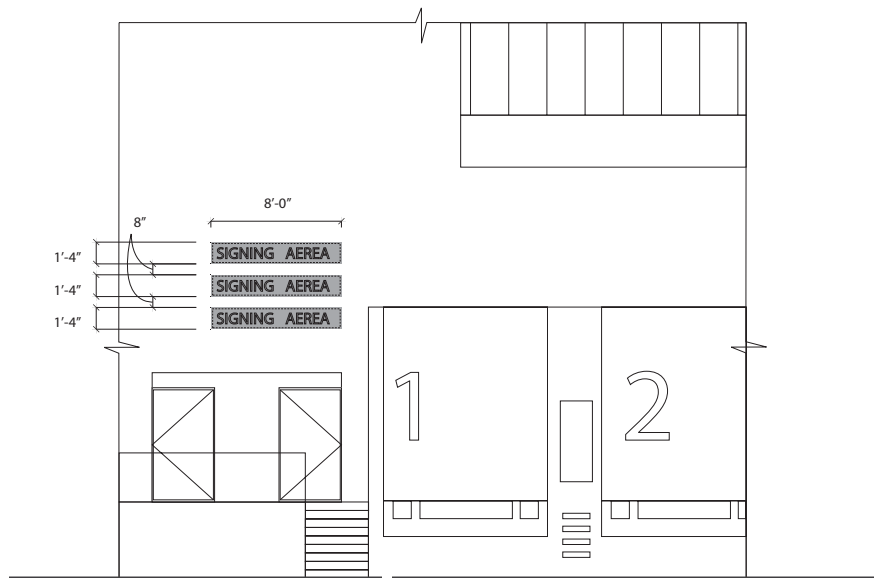

PARTIAL ELEVATION - BUILDING 57, 58, 61, and 62  
Scale: N. T. S.

**ST-562 CARGO BUILDINGS - IDENTIFICATION**  
**BUILDINGS 57, 58, 61, AND 62**

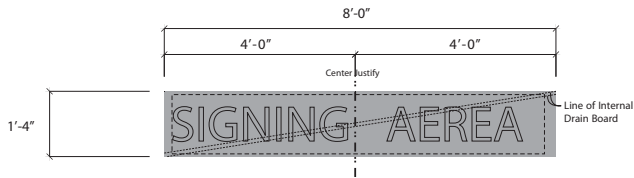

SIGNING AREA LAYOUT  
 Scale: 3/8"=1'-0"

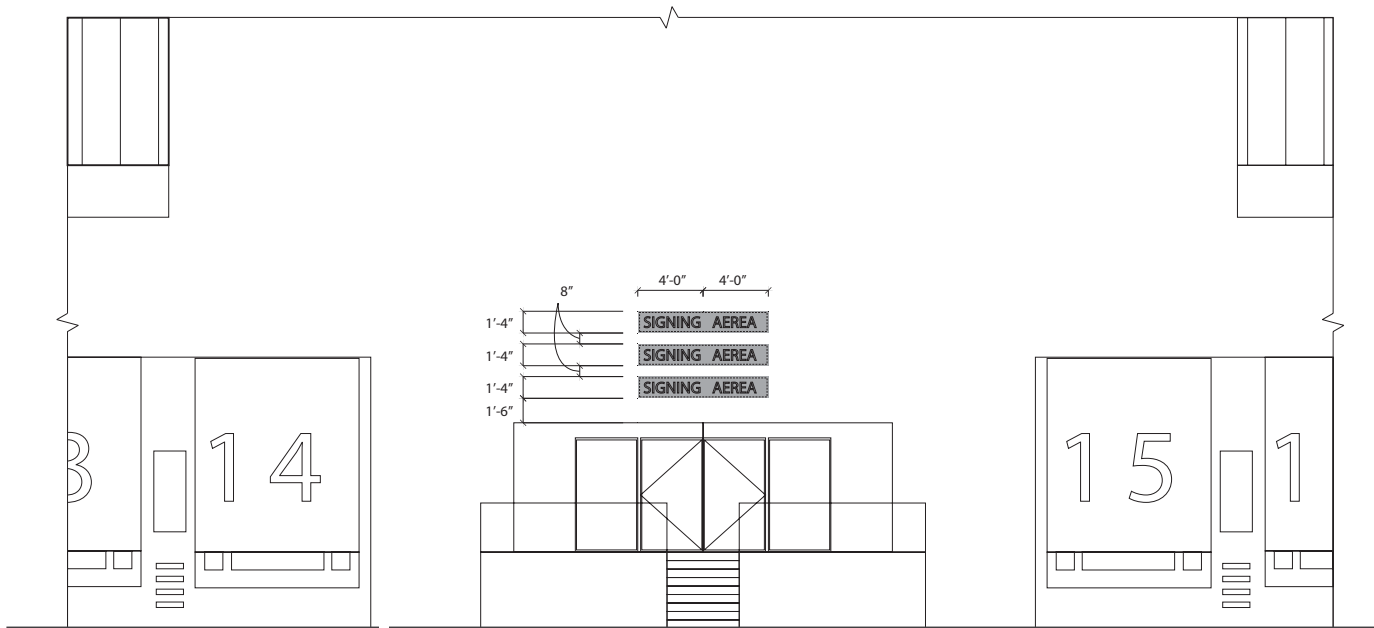

PARTIAL ELEVATION - BUILDING 57, 58, 61, and 62  
 Scale: N. T. S.



# Appendix

## Specification

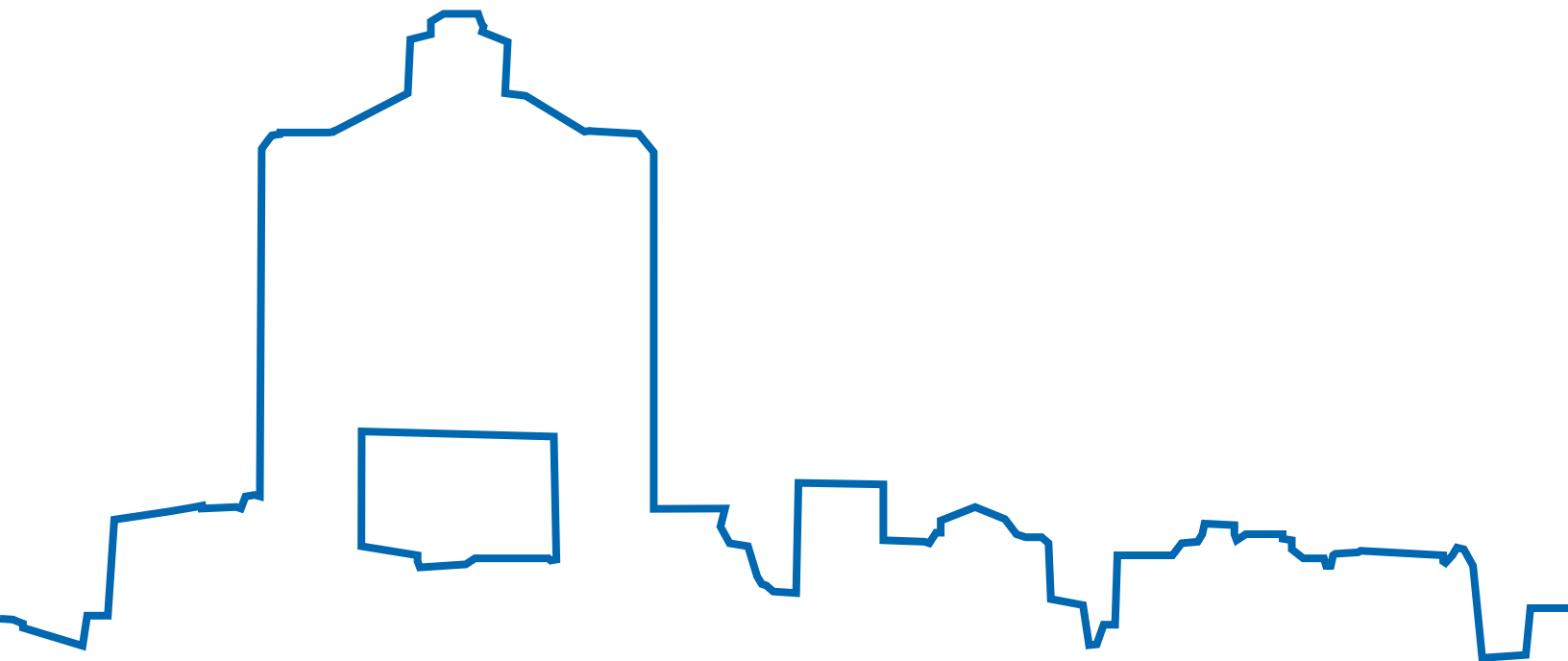

## **SPECIFICATION SECTION 10430 - ARCHITECTURAL SIGNAGE SYSTEMS**

A standard signage specification is provided as a reference for designers. It is to be incorporated and modified as appropriate by the signage designer for inclusion in Contract Documents.

## SECTION 10430

### ARCHITECTURAL SIGNAGE SYSTEMS

#### PART 1 GENERAL

##### 1.1 SUMMARY

- A. Work of this Section shall include labor, tools, materials, equipment, and services required to engineer, fabricate, construct, pack, ship, and install signs, including, but not limited to graphics and sign components as shown on the Contract Drawings, as specified herein and as required to furnish and install a complete installation.
- B. This Section includes the following sign types as designated in the Contract Drawings:
  - 1. Type A Non-Illuminated, Pendant mounted
  - 2. Type A-I Illuminated, Pendant mounted
  - 3. Type B Non-illuminated, Surface mounted
  - 4. Type B-I Illuminated, Surface mounted
  - 5. Type C Non-illuminated, Cantilever mounted
  - 6. Type C-I Illuminated, Cantilever mounted
  - 7. Type D Overhead Specialty
  - 8. Type E Pendant mounted over roadway
  - 9. Type F Flag
  - 10. Type G Plaque
  - 11. Type H Column wrap
  - 12. Type S Specialty
- C. Coordinate Work of this Section with trades providing structural support systems to which the signs are attached, electrical power and control systems, and cooperate with such trades to assure the steady progress of Work of this Section.

##### 1.2 REFERENCES

- A. Reference Standard: Massachusetts Port Authority – Wayfinding Guideline & Signage Standards dated 2013.
- B. The following is a listing of the publications referenced in this Section:

American Architectural Manufacturers Association (AAMA)

1. AAMA 611 Voluntary Specification for Anodized Architectural Aluminum.
2. AAMA 2605 Voluntary Specification, Performance Requirements, and Test Procedures for Superior Performing Organic Coatings on Aluminum Extrusions and Panels.

American Association of State Highway and Transportation Officials (AASHTO)

1. AASHTO LTS-4 Standard Specification for Structural Supports for Highway Signs, Luminaires, and Traffic Signals.

American Society for Testing and Materials (ASTM)

1. ASTM A 167 Specification for Stainless and Heat-Resisting Chromium-Nickel Steel Plate, Sheet, and Strip.
2. ASTM A 591 Standard Specification for Steel Sheet, Electrolytic Zinc-Coated, for Light Coating Weight [Mass] Applications.
3. ASTM A 653 Specification for Steel Sheet, Zinc-Coated (Galvanized) or Zinc-Iron Alloy-Coated (Galvannealed) by the Hot-Dip Process.
4. ASTM A 780 Practice for Repair of Damaged and Uncoated Areas of Hot-Dip Galvanized Coatings.
5. ASTM A 1008 Specification for Steel, Sheet, Cold-Rolled, Carbon, Structural, High-Strength Low-Alloy and High-Strength Low-Alloy with Improved Formability.
6. ASTM B 209 Standard Specification for Aluminum and Aluminum-Alloy Sheet and Plate.
7. ASTM B 221 Standard Specification for Aluminum-Alloy Extruded Bars, Rods, Wire, Profiles, and Tubes.
8. ASTM C 297 Standard Test Method for Flatwise Tensile Strength of Flat Sandwich Constructions.
9. ASTM C 346 Standard Test Method for 45-deg Specular Gloss of Ceramic Materials.
10. ASTM C 481 Standard Test Method for Laboratory Aging of Sandwich Constructions.
11. ASTM D 256 Standard Test Method for Determining the Izod Pendulum Impact Resistance of Plastics.



12. ASTM D 523 Standard Test Method for Specular Gloss.
13. ASTM D 790 Standard Test Methods for Flexural Properties of Unreinforced and Reinforced Plastics and Electrical Insulating Materials.
14. ASTM D 1003 Standard Test Method for Haze and Luminous Transmittance of Transparent Plastics.
15. ASTM D 1044 Standard Test Method for Resistance of Transparent Plastics to Surface Abrasion.
16. ASTM D 2244 Standard Practice for Calculation of Color Tolerances and Color Differences from Instrumentally Measured Color Coordinates.
17. ASTM D 4802 Standard Specification for Poly (Methyl Methacrylate) Acrylic Plastic Sheet.
18. ASTM G 154 Practice for Operating Fluorescent Light Apparatus for UV Exposure of Nonmetallic Materials.

American Welding Society (AWS)

1. AWS D1.1 Structural Welding Code, Steel.
2. AWS D1.2 Structural Welding Code, Aluminum.

Glass Association of North America (GANA)

1. Glazing Manual.
2. Sealant Manual.

Military Specifications

1. DOD-P-15328D Primer (Wash), Pretreatment (Formula No. 117 for Metals).

National Association of Architectural Metal Manufacturers (NAAMM)

1. Metal Finishes Manual for Architectural and Metal Products.

National Fire Protection Association

1. NFPA 70 National Electrical Code.

The Society for Protective Coatings (SSPC)

1. SSPC-Paint 20 Paint Specification No. 20 Zinc-Rich Coating (Type I, "Inorganic" and Type II, "Organic").
2. SSPC-SP 1 Surface Preparation Specification No. 1 Solvent Cleaning.

3. SSPC-SP 5 Surface Preparation Specification No. 5 White Metal Blast Cleaning.
  4. SSPC-SP 8 Surface Preparation Specification No. 8 Pickling.
- C. Comply with the following codes and standards to the extent that they would apply if the Authority were a private corporation:
1. American Institute of Graphic Arts (AIGA) guidelines, and the ADA Report from Kessler McGuiness dated 02 February 2009.
  2. The Americans with Disabilities Act Accessibility Guidelines (ADAAG).
  3. 780 CMR 8<sup>th</sup> Edition Massachusetts State Building Code.
  4. National Fire Protection Association (NFPA) regulations.
  5. Occupational Safety and Health Act (OSHA) standards.
  6. Society for Environmental Graphic Design (SEGD) Sourcebook.
  7. U.S. Department of Transportation Federal Highway Administration Manual on Uniform Traffic Control Devices for Streets and Highways (MUTCD) 2009 Edition (Revised May 2012).

### 1.3 DESIGN AND PERFORMANCE REQUIREMENTS

#### A. General

Submit design calculations for sign panels and structural supports, signed and sealed by a Professional Engineer licensed in Massachusetts, indicating compliance with these Design and Performance Requirements.

1. Structural supports shall be capable of carrying total supported load (including sign, hangers, and attachments) and specified live, wind, and earthquake loads.
2. Exterior sign design shall allow for thermal movement resulting from a maximum ambient temperature change (range) of 100 degrees F. Base design on actual surface temperatures of materials due to both solar heat gain and nighttime-sky heat loss.
3. Sign assemblies shall be designed to prevent buckling, opening up of joints, and overstressing of welds and fasteners.

#### B. Interior Signage

1. Wind Gust Loads Interior signs located in the entrance lobbies, entrance vestibules, or boarding platforms of transportation terminals including curbside pedestrian and vehicular access areas shall be designed for an incidental wind

gust pressure of 15 psf. All other interior signs shall be designed for a minimum lateral pressure of 5 psf.

2. Earthquake Loads Interior signs shall also be designed for earthquake loads per the applicable local building code, as though the Authority were a private corporation.
3. Live Load Signs which require routine cleaning or servicing (i.e. variable message, internally illuminated, etc.), whether or not specifically designed for a servicing device, shall be designed for all anticipated additional loads, but not less than a 100-lb. concentrated horizontal load and a 300-lb. concentrated vertical load simultaneously applied at the point of assumed or most eccentric loading. The additional concentrated loads shall be calculated in combination with the sign-dead load (not concurrent with wind or earthquake loads).

C. Exterior Signage

1. Wind Load Exterior signs adjacent to vehicular traffic such as streets, highways, trains and light rail vehicles, or in open terrain, shall be designed in accordance with AASHTO LTS-4. All other exterior signs shall be designed per the applicable local building code, as though the Authority were a private corporation.
2. Live Load Signs which require routine cleaning or servicing (i.e. variable message, internally illuminated, etc.), whether or not specifically designed for a servicing device, shall be designed for all anticipated additional loads, but not less than a 100-lb. concentrated horizontal load and a 300-lb. concentrated vertical load simultaneously applied at the point of assumed or most eccentric loading. The additional concentrated loads shall be calculated in combination with the sign dead load (not concurrent with wind or earthquake loads).

D. Connection Support

Sign support structures shall be directly connected to structural elements such as structural steel or structural concrete. Connections shall not be made to architectural, mechanical or electrical components.

1.4 QUALITY ASSURANCE

- A. Ensure that entities performing the fabrication and installation Work of this Section have five (5) years experience in the fabrication and installation of signage involving complexities equal to or greater than those required for the Work of this Section.
- B. Completed Work shall be structurally sound and free from scratches, abrasions, distortions, chips, breaks, blisters, holes, splits, and other disfigurement considered as imperfections for the specific material.
- C. Uniformity of Manufacture: For each sign type shown on the Contract Drawings furnish products of a single manufacturer.

- D. Upon request, arrange for the Engineer to inspect the sign fabrication facilities to observe fabrication of Work of this Section to ensure conformance to Contract Document requirements. Refer to Division I - General Requirements and Covenants, Article entitled "CONTROL OF WORK."
- E. Mock-ups
  - 1. Provide fabrication and finish mockups of representative portions of each sign type for approval prior to fabrication of full size mockups.
  - 2. Supply one mock-up of each sign type shown on the Contract Drawings. Mock-ups shall serve as quality standards for the Work of this Section.
  - 3. Install mock-ups at locations identified by the Engineer.
  - 4. Equip illuminated mock-ups with specified luminaries, switches and ballasts and make the mock-ups fully operational.
  - 5. Construct mock-ups to the level and degree of fabrication and finish proposed for Work of this Section. Mock-ups, if approved by the Engineer, may be installed on site as part of the Work.
  - 6. Remove rejected mock-ups from Authority property.

#### 1.5 DELIVERY, STORAGE, AND HANDLING

- A. Deliver signs in protective wrapping and store protected from weather, moisture and soiling. Coordinate on-site storage with the Engineer.

#### 1.6 GUARANTEE

- A. Contractor shall execute and submit a Guarantee, acceptable to the Engineer, that Work of this Section is in accordance with the Contract Documents and free from faults and defects in materials and workmanship for a period of five (5) years from the date of issuance of the Certificate of Final Completion.
  - 1. Guarantee shall cover, but not be limited to:
    - a. Color fastness against fading or chalking.
    - b. Non-yellowing of acrylic.
    - c. Assembly, construction and operation.
    - d. No noticeable cracking, chipping, peeling or delamination.
    - e. Uniformity of light in sign illumination.
    - f. Structural failure.

- B. Contractor shall submit extended Warranties provided by suppliers of materials and finishes.

## 1.7 SUBMITTALS

Submit the following:

### A. Product Data

1. Submit manufacturer's literature and descriptive data including catalog sheets for materials and systems, instructions for cleaning, equipment and fixtures showing control, schedule, and other pertinent information as required.
2. Where printed materials describe more than one product or model, clearly identify which is submitted for approval.
3. Submit data for fire-retardant treatment type for plywood, if any.

### B. Shop Drawings

1. Mark Shop Drawings and samples to show name and address of project, Engineer, Contractor, manufacturer and supplier.
2. Identify the locations where materials or equipment are to be installed. Show the various parts of the sign construction, including: fastenings, anchorage, lighting, details of lighting fixture supports, electrical fixtures and connections, wiring, stiffening, bracing, types and thicknesses of metal, finishes and complete instructions regarding concealed joints, welds and adjacent and related Work.
3. Submit erection drawings for the complete installation of the signs.
4. Submit staging and phasing drawings and installation schedule.

### C. Sign Layouts

1. Deliver digital files and quarter size printouts of all sign faces for approval as described in 2.4C.

### D. Samples

1. Submit samples of each sign type to demonstrate quality of fabrication methods, material finishes and color. Samples shall be subject to approval by the Engineer.
2. Submit samples of required finish materials and graphics processes for signage.

3. Color match Engineer's samples for sign support coating and for sign panel paint or finish system. Submit color chips on samples of actual materials in each color required by project to be used for sign construction, including light fixture finishes. Minimum sample size is 12-by-12 inches.
4. Vinyl lettering and graphics shall include at least one uppercase and one lowercase letter of each lettering style and one of each type of graphics shown on the Contract Drawings. Submit actual full size letterforms and graphics of each size to be used, mounted on samples of actual materials to be used for Work of this Section.
5. Silkscreen lettering and graphics shall include at least one uppercase and one lowercase letter of each lettering style and one of each type of graphics shown on the Contract Drawings. Submit actual full size silk-screen letterforms of each size and style of letters shown on Contract Drawings to be used mounted on samples of actual materials to be used for sign construction.
6. Stencil-cut aluminum with pushed-through acrylic for fabrication of illuminated signs, including accessory materials. Submit samples for both pylon type signs and sign boxes or bands.. Supply one uppercase and one lowercase letter form for each lettering style shown on the Contract Drawings.
7. Exposed trim, connections and closures. Submit color and material samples of actual materials to be used.
8. Each sample submittal shall have a typed label showing:  
Name of project.  
Address of project.  
Contractor's name.  
Name and description of item represented.
9. Record Samples
  - a. Sign Panel Materials and Sign Graphics: Furnish one 6-inch-by-6-inch sample of each different sign panel material and finish type and of each graphic material type with sample letter used in the Work of this Section. Mark each sample with typed label per C.8 above. Deliver samples to the Engineer. Samples shall become the property of the Authority.
  - b. Digital Files, Silk-Screens and Film Positives: Deliver to the Engineer in good, usable condition to become the property of the Authority. Number in accordance with the Type and nomenclature.

D. Design Calculations

Submit design calculations for sign panels, foundations, and structural supports.

F. Guarantees

1. Sample of guarantee for materials and workmanship.
  2. Sample of material and finish extended warranties.
- G. Qualifications For entities specified in this Section (professional engineer, fabricator and installer), verifying their capabilities and experience. Include list of completed projects with project names, addresses, names of architects, owners and other information specified.
- H. No signs shall be fabricated until submitted sign faces are verified and approved by the Architect and the Authority.

## 1.8 TEMPORARY SIGNAGE

- A. The Contractor shall provide all temporary signage. Temporary signage shall include roadway closure and detour signage, and temporary Wayfinding signage. The Contractor shall submit a plan for providing roadway closure and detour signage and for maintaining Wayfinding signage for each phase of work, throughout the project duration. The Contractor shall not proceed with the work until the plan for temporary signage has been approved, by the Authority, for that phase of work.

## PART 2 PRODUCTS

### 2.1 MANUFACTURERS

- A. Subject to compliance with the requirements of this Section, furnish and install products by the following, or approved equal:

Sign Fabricators:

Design Communications, Ltd., Boston, MA  
Eastern Sign Industries, Inc., Irvington, NJ  
Signal Sign Co., Livingston, NJ  
Signs + Decal Corp., Brooklyn, NY  
Spectrum Signs Inc., Farmingdale, NY

LED Fabricators:

D3 LED, North Bergen, NJ  
Daktronics, Inc., Rocky Hill, CT  
Data Display USA, [www.ddusa.com](http://www.ddusa.com)  
Multimedia LED, Rancho Cordova, CA  
Sunrise Systems, Pembroke, MA

LED Lighting Systems:

Eco Light, Sparks, NV  
GE Lumination, Cleveland, OH  
Sloan LED, Ventura, CA

## 2.2 MATERIALS

The following materials shall be used, as applicable. Material gages and thicknesses shall be as shown on the Contract Drawings or, if not shown, as specified in this Section. Refer to 2.5 for Shop Finishing.

### A. Structural Steel and Miscellaneous Steel Framing and Supports

1. Sizes and shapes shown on Contract Drawings.

### B. Lighting and Variable Message Systems

#### 1. LED

- a. LED pixel coloration to be amber or as per contract documents.
- b. LED letterforms shall be equipped with internal light-level sensors for registration and regulation of brightness, and shall be programmable for variable intensity effect.
- c. LED module matrix shall follow the general configuration as described in the Contract Drawings.
- d. Contractor shall provide for approval by the Engineer a series of mock-ups using LEDs in several variations of pixel spacing for a specified letterform to finalize LED matrix and brightness level. Brightness and color shall meet all ADA Guidelines.
- e. See Part 2.6 for additional LED light requirements.

### C. Aluminum Sheet

Alloy and temper recommended by the aluminum producer or finisher for the type of use and finish shown on the Contract Drawings, and with not less than the strength and durability properties specified in ASTM B 209 for alloy 6061-T6.

### D. Aluminum Extrusions

Alloy and temper recommended by the aluminum producer or finisher for the type of use and finish shown on the Contract Drawings, and with not less than the strength and durability properties specified in ASTM B 221 for alloy 6063-T5.

### E. Steel Sheet



1. Commercial quality cold-rolled carbon steel sheet, stretcher leveled, complying with the following requirements as applicable:
  - a. Electrolytic Zinc-Coated Steel Sheet: ASTM A 591, with Class C zinc coating, chemically treated in mill with phosphate solution and light chromate rinse.
  - b. Uncoated Steel Sheet: ASTM A 1008, exposed, matte finish.
  - c. Galvanized Steel Sheet: ASTM A 653, Coating Designation G 90, mill phosphatized.

F. Stainless Steel

Type 316L, plate, sheet or strip, complying with ASTM A 167.

G. Cast Acrylic Sheet

Cast (not extruded or continuous cast) methyl methacrylate monomer plastic sheet, ASTM D 4802, classification category A-1, smooth finish, UV absorbing, in sizes and thicknesses indicated on Contract Drawings, minimum flexural strength of 16,000 psi when tested in accordance with ASTM D 790, minimum allowable continuous service temperature of 176 degrees F (80 degrees C), unless otherwise noted.

1. At cutout acrylic lettering and graphics locations: Clear transparent and white translucent sheet of densities required to produce uniform brightness and minimum halation effects.
2. At silk screen graphics locations: White translucent sheet of density required to produce uniform brightness and minimum halation effects.
3. At color sheet graphics locations: Clear transparent facing sheet and white translucent backing sheet, same as sheets specified above for silk screen graphics locations.
4. Where "clear" sheet material is shown, furnish colorless sheet in matte finish.
5. Where "opaque" sheet material is shown, furnish colored opaque acrylic sheet in colors and finishes shown or, if not shown, as selected by the Engineer from the manufacturer's standards.

H. Colored Coatings for Cast Acrylic Sheet:

1. Where silk screen graphics are shown on the Contract Drawings: Colored coatings, including inks and paints for copy and background colors, shall be as recommended by acrylic manufacturers for optimum adherence to acrylic surface and non-fading for application shown on the Contract Drawings.

2. Where color sheet film graphics are shown on the Contract Drawings: Photographic sheet graphics placed between two cast acrylic sheets (specified above). Photographic sheet graphics shall be "Duratrans RA" display material, manufactured by Kodak, or approved equal. Finished sheet shall include a minimum 7.0 mil thick translucent base and shall be produced by using "Ektacolor RA" chemicals, manufactured by Kodak, or approved equal.

I. Polycarbonate Sheet

Clear, cast polycarbonate sheet with abrasion resisting coating on both sides, in sizes, types, and thicknesses shown on the Contract Drawings.

1. Strength: Minimum flexural strength of 13,500 psi when tested in accordance with ASTM D 790; Izod impact resistance of 16 lbf per inch when tested in accordance with ASTM D 256.
2. Service Temperature: Maximum allowable continuous service temperature of 240 degrees F.
3. Abrasion Resistance: Maximum 3 percent haze increase for 100 revolutions of a 500g Taber abraser when tested in accordance with ASTM D 1044.
4. Light Transmittance: Minimum 84 percent light transmittance for 1/4 inch thick clear sheet when tested in accordance with ASTM D 1003.
5. Sheet for message panel shall be white translucent.

J. Vinyl Film

Computer generated electro-cut and die-cut vinyl, pressure-sensitive legends, 3M Company "Scotchcal" sheeting film, or approved equal. Execute die-cutting in such a manner that edges and corners of finished letterforms are true and clean. Letterforms with round positive or negative corners or with niched, cut or ragged edges are not acceptable.

1. Thickness: Maximum 0.003 inch.
2. Adhesive Quality: Minimum 55 oz. per inch width, after curing for 24 hours, required to break adhesive bond.
3. Cut in accordance with manufacturer's printed instructions.
4. Vinyl for message panel shall be translucent.

K. Glazing Accessories

Setting blocks, spacers, compressible fillers and gaskets, setting points and other accessories required for the installation as recommended by the GANA's Glazing Manual and FGMA's Sealant Manual, for dry glazing system with compression gaskets.

Gaskets shall be cellular, neoprene custom size and configuration as required, with pressure adhesive on one side. Neoprene filler rods, sealants and other accessories shall be as shown on Contract Drawings and as required for weather-tight and light-tight installations.

L. Fasteners

Same basic metal and alloy as fastened metal, unless otherwise shown on the Contract Drawings. Do not use metals that are corrosive or incompatible with metals joined.

1. Types, gages, and lengths to suit installation conditions.
2. Concealed fasteners for interconnecting sheet metal fabrications and attachment to other construction.

M. Anchors and Inserts

Stainless steel or hot-dipped galvanized anchors and inserts as required for corrosion resistance, hidden when possible. Include inserts as required, to be set into substrate.

N. Mounting Tapes and Adhesives

Adhesives, as recommended by sign manufacturer, to suit installation conditions; "VHB" (Very High Bond) tape for mounting sign plaques, as manufactured by 3M Company, or approved equal.

O. Mastic Sealant

Polyisobutylene; nonhardening, nonskinning, nondrying, nonmigrating sealant.

P. Gaskets

Tubular or fingered design of neoprene or polyvinyl chloride, or block design of sponge neoprene.

Q. Galvanizing Repair Paint

High zinc dust content paint for regalvanizing welds in galvanized steel, with dry film containing minimum 94 percent zinc dust by weight, and complying with SSPC-Paint 20.

R. Bituminous Paint

Cold-applied asphalt mastic containing no asbestos fibers.

2.3 CONSTRUCTION FEATURES

A. Sign framing, panels, graphics, and finish shall be as shown on the Contract Drawings.

- B. Ceiling Mounted Signs fabricated of metal sheet and steel framing with copy on either one or two faces, as shown on the Contract Drawings.
- C. Wall Mounted Signs and Plaques fabricated of metal sheet or plastic laminate and directly mounted to wall or fascia as shown on the Contract Drawings.
- D. Pylon Signs Square, triangular, rectangular shaped in plan, or as shown, in the form of either a tower or slab. Fabricated of metal sheet or aluminum sandwich panels and steel framing, as shown on the Contract Drawings.
- E. Roadway Signs fabricated of metal sheet, aluminum sandwich panels and steel framing, as shown on the Contract Drawings.
- F. Post and Panel Signs post mounted units fabricated of metal sheet and either aluminum or steel framing as shown on the Contract Drawings.
- G. Suspended and Wall-Mounted Signs fabricated of metal sheet or aluminum sandwich panels, and either directly mounted to a building fascia or facade or suspended by steel or aluminum framing, as shown on the Contract Drawings.
- H. Reflective vinyl shall be used for exterior applications. Comply with U.S. Department of Transportation's MUTCD requirements.
- I. Lighting and Variable Message Systems, including transformers, insulators, and other accessories for operability, with provision for servicing and concealing connections to building electrical system, as shown on the Contract Drawings. Use tight or sealed joint construction to prevent unintentional light leakage. Space lamps apart from each other and away from sign surfaces as needed to illuminate evenly. Assemblies and components shall be UL Rated.

## 2.4 FABRICATION

### A. General

Work shall be fabricated to details shown on the Contract Drawings and on the approved Shop Drawings, and shall be first class workmanship in accordance with the best trade practices. Cutting, fabrication and assembly shall be performed in the factory. Joints, corners, mitres and splices shall be accurately machined, filled, fitted and filed, rigidly framed together at joints and contact points, and painted smooth to give a monolithic appearance with imperceptible joints; there shall be no visible connections. Mechanical fasteners shall match color and finish of the sign where they occur. Exposed metal surfaces shall be smooth with unblemished finish. The completed sign shall be shipped to the job site as one complete unit.

- 1. Materials shall be selected for their surface flatness, smoothness and freedom from surface blemishes wherever exposed to view in the finished unit. Exposed-to-view surfaces that exhibit pitting, seam marks, roller marks, "oil canning", stains, discolorations or other imperfections on the finished unit are not acceptable.

2. Surfaces shall be covered with a protective cover non-deleterious to finish for protection until final installation or erection.
  3. Field measurements shall be taken prior to preparation of Shop Drawings and fabrication.
  4. Sandwich panels shall be made in lengths up to a maximum of 24 feet and shall be designed to be mounted horizontally. Locations of horizontal joints shall be determined by the layout of graphics on the signs in order to minimize graphics overlapping the joints. Minimum panel width shall be 2 feet and overall sign panel sizes shall be as shown on the Contract Drawings. Maximum span between supports on 1 inch panels shall not exceed 9 feet.
  5. Where aluminum is fastened to steel or other dissimilar metal, or where aluminum is in contact with concrete or masonry, contact surface shall be given a heavy coating of bituminous paint.
  6. Form closures and trim members to profiles shown using the gage sheet metal shown. Furnish components required for support and installation of closures and trim. Fabricate closures and trim to tightly close with adjoining Work. Finish exposed edges of trim and closure strips. Joints in exposed Work shall not vary more than 1/32 inch in either width or alignment.
  7. Locate fasteners to be concealed wherever possible, otherwise to be as inconspicuous as possible. Size fasteners to securely support the Work, and space to prevent buckling or waviness of the finished surface. Exposed fasteners shall be countersunk and filled to match finish.
  8. Drill and tap holes required for securing closures to other surfaces. Fasteners shall be hidden from view or countersunk flush to surface.
  9. Joints shall have contiguous concealed support to hold meeting faces in flush alignment. Miter or cope trim members at corners to form tight joints.
- B. Welding, Brazing and Soldering Comply with AWS D1.1 and D1.2 and NAAMM for recommended procedures in welding, brazing, and soldering. Use filler metals that blend with and match the color of sheet metal being used and the required exposed finish appearance of the metals. Continuously weld, braze or solder corners and seams, and grind smooth and flush on exposed surfaces. Discoloration or stains between base metal and filler metal are not acceptable for exposed portions of natural metal finish.
1. Clean, pretin, heat, flux, and sweat solder through full contact area of surfaces to be joined, in accordance with best standards of practice. Remove flux residue and foreign matter after soldering. Rinse soldered areas with water and wipe clean.

C. Graphics

1. The standard for sign messages shall be as shown on the Contract Drawings. Produce "camera-ready" artwork as required based on design furnished by the Engineer as digital files produced using the latest version of Adobe Creative Suite software.
2. Messages
  - a. Graphic elements are to be based on the Massport Wayfinding Guideline & Sign Standards. Letterforms, numbers, and symbols for vinyl applications, silk-screens or die-cuts shall be prepared from photographic reproductions of repro-proofs of type set copy or computer-generated sign layouts. Digital files on disk, full size prints of each sign type, and quarter size printouts of each sign face shall be submitted to the Engineer for approval, prior to preparation of vinyl lettering or silk-screens. Film positives shall be submitted to the Engineer for approval, prior to preparation of silk-screens or vinyl lettering.
  - b. Silk-screen printing or vinyl die-cutting shall be executed in such a manner that edges and corners of finished letterforms are sharp, true, and clean. Copy with rounded positive or negative corners, edges built-up, bleeding or spattering, shall not be acceptable. Prepare each silk-screen in one continuous piece to accommodate total message coverage, unbroken horizontally or vertically.
  - c. Digital Files, silk-screens, and film positives shall be turned over to the Engineer.
  - d. Silk-screen messages and symbols shall be per Contract Drawings and "camera-ready" artwork. Paint or ink shall be of the finest quality of heat, moisture, and fade-proof pigments and vehicles.
  - e. Paint or ink shall be of type specially formulated and manufactured for application on the surface material upon which it is to be applied and recommended for such use by the manufacturer of the paint or ink. Priming, surface preparation, and application of materials shall be in strict accordance with the manufacturer's written product data and description and as otherwise necessary to produce a finish free of blistering, bleeding, fading, and other imperfections. Paint shall be ordered or mixed in quantity to assure consistent application for signs. Finishes shall be as approved by the Engineer during Shop Drawing review.
    - 1) Inks shall be products manufactured by companies listed in the Massport Wayfinding & Sign Standards, or approved equal that are specifically suited for applications shown on the Contract Drawings.

D. Internally Illuminated Signs

1. Assemblies and components shall be UL Rated with internal housings and baffles shall be of aluminum sheets or bent plates in gages and thickness as shown on the Contract Drawings or, if not shown, as required by this Section.
2. Lamping and box design shall be such that even, consistent illumination is achieved across the sign face from edge to edge. Hot or cold spots, shadows, or ghosting are not acceptable.
3. Trans-illuminated sign face must be at ample brightness to match Standard PMS colors as specified in the Massport Wayfinding & Sign Manual.
4. Interior of sign box shall be lined with optical lighting film and light enhancement film to maximize light projection.
5. Graphics display shall use one of the following methods, or as shown on Contract Drawings:
  - a. Silk screen graphics or color sheet graphics as specified in this Section.
  - b. Cutout Copy: Machine-cut letters, numbers, symbols, and other graphic devices through the sign panel to produce precisely formed copy. Use high-speed cutters mechanically linked to master templates in a pantographic system, or equivalent process capable of producing characters of the style shown on the Contract Drawings with sharply formed edges.
    - 1) Backup 0.125 inch thick acrylic sheet backup attached to backside of the panel.
    - 2) Pushed-Through Graphics Precise-fitting copy cut from 0.250 inch-thick transparent acrylic sheet projecting through engraved copy, chemically welded to 0.125 inch-thick acrylic sheet backup, where pushed-through graphics are shown on the Contract Drawings. Apply vinyl films where shown on the Contract Drawings.
6. Wiring within the sign shall be installed in accordance with the National Electrical Code and shall be neatly arranged and supported.
7. Ballasts shall be individually fused in an approved manner.
8. Wire terminals, taps, and other electrical connectors shall be of an approved swaged, clinched or positive clamping type. Plain soldered lugs with no means of mechanically holding the wire without solder are not permitted.
9. Lamps, ballasts, and fuses shall be arranged so that they are readily accessible for maintenance. Determine actual types, lengths and wattages required for

individual and fully legible signs. Furnish suitable lamps for interior and exterior use as required for even illumination of messages.

10. Illuminated signs shall be connected into the existing building circuitry. Install conductors from the existing junction boxes or relays to the service entrances in the signs in order to provide power to the lamps. The exact location of existing junction boxes or relays shall be determined in the field before making provisions for concealed service entrances in the signs. Make electrical fixture and power connections.
11. Illuminated signs shall be furnished with vent holes protected with insect screening, and adequately light proofed.
12. Illuminated signs shall be of weather-tight construction.
13. Furnish prop bar for ease in relamping.
14. Furnish an ON/OFF switch and a photocell-operated switch in an inconspicuous location, for the individual operation of each sign for maintenance purposes.

E. Lighting Fixtures for Externally Illuminated Roadway Signs

1. Sign lighting fixtures shall be of the type specified hereinafter and shall be complete with self-contained ballasts, wired for operation and mounted and supported as shown on the Contract Drawings.
2. Fixtures shall be dust-tight, weather-tight and suitable for outdoor use. Ballasts shall be of the high power factor type and shall bear the stamp of approval of the Electrical Testing Laboratory. Ballasts and lamps shall be suitable for operation at temperatures down to minus 20 degrees F. Ballasts shall be fused with the proper size fuse as recommended by the manufacturer. The fuse holders shall be type HLR and equipped with type GMF glass tube fuses as manufactured by Bussman Manufacturing Company, or approved equal.
3. Fixture housings shall be constructed of 18-gage (0.040 inch) aluminum, ASTM B 209, alloy 3003-H14, welded construction.
4. Exterior surfaces of fixtures shall be field painted or shall receive a factory-applied finish as shown on the Contract Drawings.
5. Fixture reflectors shall be minimum 0.020 inch thick aluminum, specular Alzak processed finish and of paracylindrical form.
6. Housing door for internal access shall consist of an enclosure lens of clear, unribbed acrylic plastic, 1/8 inch thick, and an enclosure frame of extruded aluminum, with vinyl or neoprene gasketing. This framed plastic door shall be connected to the fixture body by a continuous extruded hinged frame member. Extruded hinge shall be constructed to form a stop so that when the door is in the



upward position it is past 90 degrees. Furnish a positive latch assembly to keep the cover in the open position and to prevent accidental release.

7. Door shall be secured in place against a polyvinyl gasket around the opening and secured with toggle action stainless steel catches.
8. Lamp sockets shall be protected by a polychloroprene moisture-proof boot.
9. Fixture shall have a barrier type terminal block for terminating the lamp socket wires.
10. Wiring shall be minimum number 10 AWG.
11. Conduit shall be watertight.
12. Signs shall be completely factory wired with at least five feet of slack to handholes at the base of support for connection to branch circuits as shown on the Contract Drawings.

F. Sandwich Panel Signs

1. Perimeter Frames: Extruded aluminum alloy 6063-T6, heliarc welded.
2. Panel Thickness: 1 inch, unless otherwise shown on the Contract Drawings.
3. Finish: As specified in this Section or as shown on the Contract Drawings.
4. Aluminum honeycomb laminate construction: Minimum tensile strength of 50 psi in accordance with ASTM C 297 and ASTM C 481.
5. Adhesives: Thermosetting epoxy type. Bonding shall be done in a heated flat platten press of sufficient size to contain the entire panel at one time with 10 psi over the entire platten area.
6. Adhesively bonded panels shall have exterior faces of such flatness when measured at normal room temperature of 70 degrees to 80 degrees F that the maximum slope of the surface at any point, measured from the nominal plane of the surface, shall not exceed 1.5 percent. Wave slope shall be computed by measuring the distance between high points and placing a straight edge across these points to determine the depth of slope. Flatness of signs shall be within a slope determination of 1 percent when checked in this manner.
7. For exterior signs, 1/8 inch diameter weep holes shall be drilled in the cap and the perimeter frame at the bottom of each panel 3 inches in from either end, and in the center of each panel.

G. Aluminum Sheet on Plywood Signs

Form sign panels of aluminum sheet, adhesively attached to fire-retardant plywood backing, as shown on the Contract Drawings.

2.5 SHOP FINISHING

A. General

1. Shop finish of signs shall be as follows and as shown on the Contract Drawings:
  - a. Aluminum Sheet on Plywood signs, or other type of sign face as shown on the Contract Drawings.
  - b. Fluoropolymer 3-Coat System on aluminum
  - c. Clear or Color Anodic on aluminum
  - d. Acrylic Polyurethane on aluminum
  - e. Baked Enamel on steel or galvanized steel
  - f. Paint on steel or galvanized steel
  - g. Stainless Steel: Finish as shown on the Contract Drawings
  - h. Powder Coating for light boxes
2. Comply with NAAMM's Metal Finishes Manual for Architectural and Metal Products for finish description and application recommendations, except as otherwise shown and specified.
3. Materials comprising a sign shall be finished with a coating system compatible with that material; priming shall be done in accordance with finisher's specification. Exposed surfaces, edges, and connections shall receive this same finish system.

B. Surface Preparation

1. Aluminum: AA-C12-C42-R1x (Chemical Finish: Cleaned with inhibited chemical conversion coating, acid chromate-fluoride-phosphate pretreatment); coating system as specified below.
2. Stainless Steel: The cleaned stainless steel surface shall be pretreated with a wash-coat conforming to Military Specification DOD-P-15328D or approved equal.
3. Before finishing, remove loose mill scale, dirt, weld flux, weld spatter, and other foreign material.

C. Color

1. Exposed sign surfaces, including panel backgrounds, shall be in a color and gloss as shown on Contract Drawings or, if not shown, as selected by the Engineer from manufacturer's custom range.
2. Messages on sign panels to be satin or matte finish white, unless otherwise shown on Contract Drawings.
3. Exposed conduit, electrical boxes, clamps, and connectors shall be painted to match sign finish.
4. Interior housing surfaces of internally illuminated signs shall be painted in a high-gloss-white enamel finish.
5. Colors and degree of gloss for surface paint and finish applications shall be consistent throughout, regardless of substrate.

D. Fluoropolymer 3-Coat System Manufacturer's standard 3-coat thermocured system composed of specially formulated inhibitive primer, fluoropolymer color coat and clear fluoropolymer topcoat, with both color coat and clear topcoat containing not less than 70 percent polyvinylidene resin by weight (Atofina "Kynar 500", or Solvay Solexis, Inc. "Hylar 5000"), complying with AAMA 2605; color and gloss as shown on the Contract Drawings or, if not shown, as selected by the Engineer from manufacturer's custom range.

E. Anodic Finish designations prefixed by "AA" shall conform to the system established by the Aluminum Association for designating aluminum finishes, listed in NAAMM's Metal Finishes Manual for Architectural and Metal Products.

1. Class I Clear Anodic Finish AA-M12-C22-A41 (nonspecular as fabricated; medium matte etched surface; Architectural Class I clear coating 0.7 mil or thicker), complying with AAMA 611.
2. Class I Color Anodic Finish AA-M12-C22-A42/A44 (nonspecular as fabricated, medium matte etched surface, Architectural Class I, integrally color or electrolytically deposited color coating 0.7 mil or thicker), complying with AAMA 611.
3. Apply protective coating of clear acrylic lacquer of not less than 0.05 mil, dry film thickness.

F. Acrylic Polyurethane on Aluminum

1. As manufactured by Matthews Paint Company, 8201 100th St., Pleasant Prairie, WI, or approved equal.
  - a. Colors must be proven to be equal in color and gloss retention to corresponding colors of Matthews Acrylic Polyurethane by United States

Testing Company, Inc., Chemical Service Div., 1415 Park Avenue, Hoboken, NJ. The laboratory test shall consist of 1,000 hours in a QUV accelerated weathering tester maintained in accordance with ASTM G 154. The tester shall be programmed to alternate 40 degrees Celsius water condensation 4-hour periods with 60 degrees Celsius ultraviolet 4-hour periods. Gloss measurements are to be made with a Hunterlab color difference meter (ASTM D 523 and D 2244, respectively).

- b. Proposed alternate coating systems shall include comparative results as indicated above from United States Testing Company, Inc., or other equivalent testing lab acceptable to the Engineer.
2. Acrylic polyurethane system shall be ultraviolet inhibited, lead, and heavy metal free.
  3. Surface to be coated shall be prepared, primed, and finish coated in accordance with coating manufacturer's instructions.
  4. Paint shall be thoroughly and evenly applied and shall be well worked into corners and joints and shall have no edge or joint build-up.
  5. Coating shall be applied at not less than the manufacturer's recommended spreading rate, to establish a total dry film thickness of not less than 4.0 mils for the entire coating system of prime/conversion coating and finish coats for 2-coat work.
- G. Baked Enamel Finish on Steel or Galvanized Steel Immediately after cleaning and pretreatment, apply manufacturer's standard 2-coat baked enamel finish, consisting of prime coat and minimum 1.0 mil dry film thickness thermosetting topcoat. Comply with paint manufacturer's instructions for application and baking to achieve total minimum dry film thickness of 2.0 mils; color and gloss shall be as shown on the Contract Drawings.
- H. Paint Finish on Steel Sheet
1. Surface Preparation Solvent-clean surfaces in compliance with SSPC-SP 1 to remove dirt, oil, grease, and other contaminants that could impair paint bond. Remove mill scale and rust, if present, from uncoated steel in compliance with SSPC-SP 5 or SSPC-SP 8.
  2. Factory-Priming for Factory Painted Finish Apply shop primer, specified in Division 9 Section on Painting, immediately following surface preparation and pretreatment.
- I. Paint Finish on Galvanized Steel Sheet
1. Surface Preparation Clean surfaces of dirt, grease, and other contaminants. Follow by a conversion coating of type suitable for organic coating application. Clean welds, mechanical connections, and abraded areas. Follow by SSPC-Paint 20 galvanizing repair paint applied in accordance with ASTM A 780.

2. Factory-Priming for Field Painted Finish Where field painting after installation is specified or shown on the Contract Drawings, apply air-dried primer, specified in Division 9 Section on Painting immediately following cleaning and pretreatment.
- J. Stainless Steel Finish Furnish one or more of the following finishes, where shown on the Contract Drawings:
1. Bright, Directional Polish: AISI No. 4 finish.
  2. Satin, Directional Polish: AISI No. 6 finish.
  3. Satin, Reflective, Directional Polish: AISI No. 7 finish.
  4. Mirror-Like Reflective, Non-Directional Polish: AISI No. 8 finish.
  5. Non-Directional Finish: No. 3 or No.4 non-directional brushed finish
- K. Powder Coating
1. Surface finish: Mechanically clean and chemically pre-treat in accordance with powder coating manufacturer and AAMA finish requirements.
  2. Use fluoropolymer meeting performance requirements of AAMA 2605. Use Duranar powder coating by PPG Industries or approved equal. 0.20 – 0.30 mil primer plus 1.5 – 3.5 mil Duranar Powder Topcoat, 1.7 mil total minimum thickness.

## 2.6 LED SIGNS

- A. Color Temperatures
1. 4100K – 6500K.
- B. Operating Temperatures
1. The LED Signs shall be designed to operate in temperatures of between 0 degrees C to +50C indoors and –40C to +65C for exterior signage.
- C. Ambient Light Sensing
1. An ambient light level sensor shall be used to adjust the brightness of the display as a function of ambient illumination on all interior and exterior units.
- D. Safety
1. Earthing and bonding will follow the recommendations of UL guidelines and statutory requirements. Safety earth bonding will be used to all metal parts of the display, connected to a proven earth point. An M6 earth stud will be provided on the inside of the main case for the attachment of the safety earth.

2. All other parts of the sign circuitry will be isolated (500 volts proof) from the earth point. Incoming mains will be fully fused.
  3. All signs will have an external safety switch.
- E. Electromagnetic Compatibility
1. Electromagnetic compatibility standards will conform to FCC directives. Standard measures will be taken to reduce susceptibility to interference and radiation of spurious signals. External data cables will be screened, mains filtering devices will be fitted at the mains input and ferrite beads used adjacent to high speed switching devices. A matrix shield will be fitted to the rear of the display front screen in order to achieve emission/immunity conformance.
- F. Reliability and Maintenance
1. Typical MTBF = 100,000 hours for LED components. 20% extra stock of LED components of each LED type to be provided to Massport.
- G. Exterior LED systems shall be of weather-tight construction.
- H. Control and Monitoring Software
1. The displays are designed to be a typical network device. The CPU shall constantly monitor the performance of the display data and the PSUs within the display. "In the Event of Failure" notification can be immediately be made to the "Management System" via the polling structure within the protocol.
  2. Control software is to be "WYSIWYG" of each sign display, showing the entire sign. Provide a single PC and LCD monitor to control all signs via local network or wireless comm. links. Locate unit as directed by Massport. One day of on site training of Massport staff to be included as well as unlimited phone support.
  2. Software features to Include:
    - a. Multiple message time scheduling
    - b. Scrolling messages
    - c. Multipage messages
    - d. Multiple text heights and fonts
    - e. Animated graphics and text
    - f. WYSIWYG editing of messages

3. Diagnostics features and controls to include:

- a. Data Failure
- b. PSU Failure
- c. Brightness Level
- d. Maintenance Active
- e. Fallback Mode
- f. Comms Failure
- g. Message Time Out
- h. Power Cycle

I. Warranty

- 1. The electronic message display cabinet will be warranted for the lifetime of the purchasing organization against defects in workmanship or materials.
- 2. The LED electronic message display will be warranted for a period of five (5) years. The unit product shall be free from defects in material and workmanship, for a period of five (5) years.

J. Power

- 1. Power provided for signage connections shall be 120 VAC.
- 2. Provide all electrical power transformation required for LED signs as part of signage system work.

## PART 3 EXECUTION

### 3.1 EXAMINATION

- A. Examine substrates and conditions under which Work is to be installed before sign components are delivered to the site. Report in writing to the Engineer conditions that will prevent proper execution of the Work or endanger its permanency. Do not proceed with Work until unsatisfactory conditions have been corrected in a manner acceptable to the Engineer. Commencement of the Work shall constitute acceptance of the conditions.

### 3.2 PREPARATION

- A. Determine location of utilities that will be within the area of the proposed signs or excavation site. Immediately notify the Engineer of conflicting conditions.

- B. Schedule installation of signs per the Phasing plan and at the convenience of the Engineer, so that the Work may be coordinated with other finishing in progress within the building. Signs shall be erected by skilled workmen especially trained in this type of work.

### 3.3 INSTALLATION

- A. Install access panels where access above existing ceilings is required and as shown on the drawings.
- B. Install signs, including sign structures, anchorages, electrical components, and required connections into existing circuits.
- C. Comply with manufacturer's product data and published instructions for material installation requirements.
- D. Install the Work in location, in alignment and in elevation, free of rack, plumb, level and straight with no distortions, measured from established lines and levels. Shim as required using concealed shims. Install to a tolerance of 1/8 inch in 8 feet for plumb and level, with maximum 1/32 inch offset in flush adjoining sign panels, and maximum 1/16 inch offsets in flush and in revealed adjoining surfaces. Level with instruments; measuring equal distances from existing building surfaces is not acceptable as a basis of level and plumb.
- E. Execute drilling, cutting, and fitting carefully and fit at job before finishing. Install anchors, expansion bolts, and anchor bolts for complete anchorage. Install supporting members, fastenings, framing, bracing brackets, straps, bolts and angles as required to set and connect signage Work rigidly and properly to underlying construction.
- F. Obtain prior approval of Engineer before field cutting or drilling galvanized steel.
- G. Set anchor bolts and anchorages with templates to correct elevations, plumb and true, where shown on the Contract Drawings, complying with approved Shop Drawings. Complete connections in proper alignment and tighten bolts securely.
- H. Sign faces shall be flat, true and free from oil canning and waviness; exposed surfaces shall not deviate from flat by more than 1/16 inch in any 36 inch distance.
- I. Bases and Pedestals Coordinate setting with Contract Drawings, diagrams, templates, instructions and directions for the installation of anchorages, such as concrete inserts, anchor bolts and miscellaneous items having integral anchors which are to be embedded in concrete or masonry construction. Coordinate delivery of such items to the construction site.
- J. Corrosion Protection: Coat concealed surfaces of exterior aluminum in contact with grout, concrete, masonry, wood, or dissimilar metals, with a heavy coat of bituminous paint.



K. Sign Posts and Supports

1. Locate field splices in the sign structures where shown on the Contract Drawings.
2. Form weather-tight joints with connections.
3. Connections shall not be visible, unless otherwise shown.
4. Install concealed gaskets, flashing, sealants, fillers, and insulation per manufacturer's recommendations as the Work progresses, to make the installations sealed.
5. Repair finishes damaged by cutting, welding, soldering and grinding operations required for shop fitting and jointing. Restore finishes and paint so that there is no evidence of corrective work. Return items that cannot be refinished in the field to the shop, make the new required alterations, and refinish the entire unit or furnish, and install new units at fabricator's option.
6. Fasteners
  - a. Fasteners shall be concealed, except where otherwise noted on Contract Drawings. Exposed fasteners, if any, shall be flush and match color and finish of adjacent surfaces.
  - b. When dissimilar metals are in contact, coat and finish the contacting surfaces compatibly to their adjacent surfaces.
  - c. Visible welding shall be continuous, ground smooth and finished; seams shall be made invisible. Internal welding shall be structurally sound and eliminate racking.

L. Tape mounting of sign faces is prohibited at all overhead and ceiling mounted signs and wall mounted signs that are located six (6) feet above the finished floor. Use mechanical concealed head fasteners to anchor the sign face in accordance with fabricator and manufacturer recommendations.

M. Touch-Up

6. Immediately after erection, clean field welds, bolted connections and abraded areas of shop paint, and paint exposed areas with same paint used for shop painting. Field apply by brush or spray to yield a minimum dry thickness of 2.0 mils.
7. Touch-up abraded galvanized surfaces with galvanized repair paint applied in accordance with ASTM A 780.

### 3.4 FIELD TESTS

- A. Test and adjust illuminated electrical signs for illumination level, hot spots, and light leaks.

### 3.5 CLEANING

- A. Upon completion of Work, remove tools, equipment, surplus, and discarded materials from the site, including debris, dirt, and rubbish accumulated as a result of the sign installation. Leave the site in a neat and presentable condition.
- B. Clean site of litter and foreign substances. Sweep paved areas to a broom-clean condition; remove stains, petrochemical spills, and other foreign deposits.
- C. Upon completion of final installation, clean surfaces of units of work to normal "clean" condition. Comply with manufacturer's instructions for cleaning operations. The following are examples, but not by way of limitation, of cleaning levels required:
  - 1. Remove temporary protective coverings and labels that are not required as permanent labels.
  - 2. Clean exposed hand-surface finishes to a dirt-free condition, free of dust, stains, films, and similar noticeable distracting substances. Avoid disturbance of natural weathering of surfaces, except as otherwise indicated. Restore reflective surfaces to original reflective condition.
  - 3. Wipe surfaces of mechanical and electrical equipment clean; remove excess lubrication and other substances.
  - 4. Clean light fixture housings and lamps to permit functioning with full efficiency.

END OF SECTION

